

MUNICIPAL ENGINEERING FOUNDATION VICTORIA

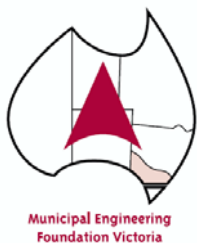

FUTURE DIRECTIONS IN ALTERNATIVE WASTE TECHNOLOGIES





[Contents](#) | [Executive Summary](#) | [Glossary of Terms](#) | [Introduction](#) |
[Tour Objectives](#) | [Methodology](#) | [Context](#) | [Resources from Waste Materials](#) |
[Waste to Energy Options](#) | [Legislation](#) | [Community Values](#) |
[Waste Facilities Visited](#) | [Issues Arising from Site Visits](#) |
[ISWA Congress Rome 2004](#) |
[Conclusions](#) | [Recommendations](#) | [Acknowledgements](#)

CONTENTS

Executive Summary	5
Glossary of Terms	9
1 Introduction	14
2 Tour Objectives	15
3 Methodology	16
3.1 WMAA Tour	16
3.2 UK Tour.....	16
3.3 ISWA Congress	16
3.4 Outcomes	16
4 Context	17
4.1 Waste Administration in Europe and Australia.....	17
4.2 Emerging Industry Trends.....	18
4.3 Sustainability/Carbon credits – Funding	19
4.4 Vision and Future Directions.....	20
4.5 Stakeholder Involvement/Ownership	23
5 Resources from Waste Materials	24
6 Waste to Energy Options	25
6.1 The Need for an Alternative to Landfill	25
6.2 Biochemical Processes	26
6.3 Terminology	26
6.4 Aerobic Digestion.....	26
6.5 Anaerobic Digestion.....	27
6.6 Thermo-Chemical Processes	27
6.7 Direct Combustion or Incineration.....	28
6.8 Pyrolysis	31
6.9 Gasification.....	32
7 Legislation Issues	34
7.1 Status of Infrastructure	34
7.2 Victorian Legislation	36
8 Community Values	38
9 Waste Facilities Visited	42
9.1 Italy.....	42
9.1.1 Vesta Spa	42
9.1.2 Ansaldo Energia Spa Verona.....	47
9.1.3 EcoDeco Spa (ITS).....	50
9.2 Switzerland	57
9.3 France	61
9.3.1 AZALYS.....	61
9.3.2 SITA il de France Recycling Centre - Genevilliers.....	64
9.3.3 SITA il de France - Limeil Brevannes.....	66
9.3.4 Plessit – Gassot Landfill	67
9.3.5 CGECP Auror (Veolia Environment/Onyx).....	70
9.3.6 Hersin Landfill.....	75
9.4 Belguim	78
9.4.1 Itradec Mons.....	78
9.4.2 Grammont – Biowaste Composting Facility	81

	9.5	Germany	83
	9.5.1	Munster (MBT)	83
	9.5.2	Beckum – Ready Mix Cement Kiln	85
	9.5.3	Lippewerke (IRR).....	86
	9.5.4	Mark Elverslingsen Power Station	91
	9.5.5	Frankfurt – RheinMain Biokompost	92
	9.5.6	Frankfurt – FES Paper Sorting	96
	9.6	Bristol UK - Compact Power	97
10		Issues Arising from Site Visits.....	105
	10.1	Government Support	106
	10.2	Legislation	107
	10.3	Funding Options	107
	10.4	Community Acceptance of Alternate Waste Disposal (AWD) Systems	107
	10.5	Siting of Facilities.....	107
	10.6	Available Technology	108
	10.7	By-Products	108
	10.8	Emerging Trends	109
	10.9	Industry Support	109
	10.10	Costs.....	109
	10.11	Influencing Factors	110
	10.12	Occupational Health and Safety Requirements	110
	10.13	Labour Requirements.....	110
	10.14	Commodity Markets	110
	10.15	Guaranteed Supply of Waste	111
11		ISWA Congress – Rome 2004.....	112
12		Conclusions	118
	12.1	Future of Landfill	118
	12.2	Future of Waste to Energy.....	120
	12.3	Collection/Transport of Wastes.....	122
	12.4	OH&S Requirements.....	123
	12.5	Legislation	123
	12.6	Need for National Coordinating Body to provide Vision, Leadership and Direction to Government and the Industry Sector on Delivery of Waste Services.....	123
	12.7	Need for National Planning/Operation Manual.....	124
	12.8	New Technologies in Europe	124
	12.9	Development of Expertise and Knowledge of Waste Industry Systems in the Local Government Sector	124
	12.10	Questions Arising.....	125
13		Recommendations.....	127
14		Acknowledgements	130
15		Useful Resource Documents	131

Appendices

- Appendix 1 - Differences between Europe and Australian Waste Environments
- Appendix 2 - WMAA 2004 Tour – Participants
- Appendix 3 - ISWA Congress Paper Abstracts
- Appendix 4 - WMAA 2004 European Tour – Sites Visited
- Appendix 5 - Greenpeace – Incineration – A Dirty Business

Executive Summary

Landfill is the traditional means of disposal of wastes, which is accepted by the Community and generally appears to be the most cost effective solution for the Australian environment. This assumption is based on the collected wastes being assessed as waste material rather than a resource.

There are a number of issues, which relate to landfill operations that make it an increasingly less viable option in today's society and for the future.

Compounded by stringent EPA Vic. Requirements, one off financial assurances and continually increasing costs for engineering solutions to minimise environmental impact, gate charges to landfill are expected to rise and in approximately 10 years be of an order cost equal or higher than the costs to access a AWT facility.

Stakeholder involvement and ownership, together with community values will dictate when and what type of facility will be required to manage the waste stream and production of 'value added' products.

Of all the facilities seen there was a requirement for landfill to dispose of the residual wastes after pre-treatment of the wastes received. The amount of wastes disposed of at landfill varied from 10% of the original volume to levels of up to 50% depending on the efficiency and effectiveness of the systems used by the operator.

Whilst the European Countries visited by the tour group demonstrated that there was technology available to treat wastes and produce 'value added' products for reuse there was no facility or system in its entirety that could be recommended for use in the Australian environment.

There is technology which could be adopted for use in the Australian environment, however, given the high capital cost of up to A\$100 million (based on 100,000 –150,000 tonnes/pa) and operating cost of up to A\$250 per tonne, it will be some time before AWT will be a viable option for the treatment of wastes in Victoria.

In the interim, it is appropriate that planning for the introduction of AWT commence and consideration be given to the use of low technology systems during the transitional period. Examples being, the use of open window composting systems to produce a compost material in preference to use of high technology in vessel or enclosed systems. Obviously, the quality of products will be of a lesser standard and yields will be lower.

To assist the change to AWT it will be necessary to have improved and uniform legislation to address the issues of scale, return on investment, the environment, carbon credits and stakeholder ownership.

Further it will also be necessary for the leaders in the waste industry to come together, and provide some leadership in addressing the formulation of a strategy, which will provide a vision and direction for the industry and Government.

It was most noticeable on the tour that in Europe the waste industry provided leadership and that the industry group provided the direction and government in the various EU countries, developed and enacted legislation which enabled implementation of programmes to allow the vision and directions to be achieved.

AWT systems have generated a great deal of interest in Australia in recent years. Interest groups, green organisations, and Governments at all levels are now showing some interest in addressing the issue of developing sustainable solutions for the handling of wastes using AWT technology. Ambitious waste reduction targets have been set and it has been hoped that AWT could deliver the required reductions without much consideration being given to the type of facility, which could be used to achieve the targets.

There is a need for forward planning and development of a manual or technical document which sets out details of all the known technologies and systems and their operating characteristics which may assist the next generation waste manager in the development of future waste management systems.

By product or value added products need to be carefully assessed, reuse options and market opportunities will often impact on the decision making process in selecting the future waste treatment/disposal system and facilities. The issue of marketing and use of green organic and biosolid wastes to provide 'value added' product is a problem common to both Europe and Australia.

Information gained on the tour suggests composted material was either disposed of at landfill or as a pre-treated input, which was sold at a very low cost. Sales at A\$5-10 tonne was the best return that could be expected. In Australia action is being taken through various studies to identify what the user requires and through appropriate marketing and product manufacture how the needs can be addressed to meet user group expectations.

Australia is different to Europe in a number of ways and the translation of technology from Europe to Australian environment needs to recognise these differences. A comparative table of differences is set out in Appendix 1.

In summary Australia has a greater opportunity, to use landfill, whilst little is landfilled in Europe. Australia has further opportunities to utilise compost 'value added' products to enrich degraded soils, improve its legislative policies and controls, review its collection and pre-treatment practices prior to disposal of wastes in landfill.

The issue of Waste to Energy and development of systems to treat wastes using AWT systems needs to be an item of discussion with representatives of the major green organisations to determine a vision for the future.

The determination of a pricing policy for the acceptance and for treatment of wastes is seen as an item for discussion between the levels of Government, the waste industry and the community.

Community acceptance of the inevitable rises in the gate prices required to implement new waste management systems is essential and needs to be addressed through ongoing Community consultation.

In addition to the above, it was found from the site visits that having regard to the future of landfill it is clear that Waste Hierarchies in both Europe and Australia place landfill as the least desirable waste disposal option. Despite this the need for landfills will remain into the foreseeable future.

Incineration of waste is considered to be a 'proven technology' in Europe with the support of the 'green' organisations a number of waste to energy plants have been established with benefits to the local community.

The issue of support for use of waste to energy technology in Australia is yet to be proven.

Matters of siting of any new facility, transport access arrangements to the facility, operation of the facility to Australian Occupational Health and Safety standards and community acceptance of the technology used will all have an impact on when where and what system will be used for the treatment of wastes in Australia.

The study tour provided an excellent opportunity for the awardees to inspect at the coalface, the facilities established to receive, and 'treat' the wastes in the various waste streams.

Our conclusion is the AWT is at an embryonic stage which will take up to 5-8 years for development in Australia and that the site visits showed clearly examples of what not to do, if costly mistakes are to be avoided in the treatment and reuse of wastes.

Questions which need to be answered in addressing AWT in the Australian environment are:

- Will the community accept AWT, and the imposition of pricing policies associated with its operation to protect the environment.
- Can we develop 'value added' markets for the materials generated by AWT system.
- Is landfill an acceptable option to AWT.
- What is the role of the Local Government Engineer in formulation of waste policy and strategies.
- What is the role of Local Government in the introduction of AWT systems, is Local Government a facilitator or developer.

In response to these questions the tour group have made a number of detailed recommendations that are set out in Section 13 of this report and they can be summarised under the headings:

- Industry Knowledge.
- Introduction of AWT technology.
- Landfill Technology.

As recommended it is appropriate that IPWEA take a leading role in the development of systems and organisations to obtain and retain knowledge of waste Management practices in the Local Government industry.

Federal Government support and funding of the development of a technical database and training of Local Government Engineers are most important.

Research and Development is needed to assess opportunities for the introduction of AWT systems.

Establishment of a peak waste industry group at the National level is essential to allow the development of waste management policy which may apply across Australia.

Consideration of the application of AWT technologies in the rural areas of Victoria is also needed together with market development for 'value added' products derived from the new systems.

In the interim pending the establishment of peak industry bodies it is recommended that the IPWEA establish a National committee comprising of Local Government Engineers with an interest in waste management determine an action plan and way forward for the introduction of AWT into the Local Government industry sector.

Work is also required on, assessment of our existing landfill disposal systems and the effects State Government policies and emerging operational trends are having on our existing landfill facilities.

As referred to in this report there is a considerable amount of work required to introduce AWT systems and technologies to the Australian environment.

We have commenced a journey and we have a way to go, which will require a new generation of well trained Local Government Engineers with expertise in waste management to ensure the most effective, sustainable waste management systems are delivered to our communities.

It is essential that as an Industry, Local Government should show some leadership through, the training of staff and facilitating an action plan on how wastes are collected processed and recovered over the next 20 years.

Glossary of Terms

A \$100: Costs or charges expressed in equivalent Australian currency at the time of the visit.

Aerobic Composting: A method of composting organic wastes using bacteria that need oxygen. This requires that the waste be exposed to air, either via turning or forcing air through pipes that pass through the material.

Aggregate: A substance formed from different materials.

Alternate Waste Disposal (AWD): Collection materials.

Alternate Waste Treatment (AWT): Technologies and systems for treatment, recovery or reuse of wastes.

Anaerobic Composting: Decomposition of organic wastes by micro-organisms, usually under wet conditions, in the absence of oxygen, to produce a gas comprising mostly methane and carbon dioxide.

Assimilated Waste (AW): Waste streams similar in composition and nature to municipal solid waste. From the characteristics and composition point of view, municipal solid waste and assimilated waste are similar.

BANANA: Build absolutely nothing anywhere near anybody.

Biogas: A combustible gas created by anaerobic decomposition of organic material comprising mainly of methane, carbon dioxide and hydrogen sulphide.

Biosolids: Sewage sludge a nutrient rich organic product generated during the treatment of domestic sewage in a treatment facility. Generally biosolids is the residue after the waste water is removed from the sewage stream.

BoneMeal: Residue from abattoir processes, ground bone and offal wastes.

Build-Own-Operate-Transfer (BOOT): The situation when a private owner builds, owns and operates an infrastructure facility and then transfers it to another entity after a specified period.

Build-Own-Transfer (BOT): The situation when a private owner builds, owns and then transfers an infrastructure facility to another party, often at no cost, after a specified period.

Build-Transfer-Operate (BTO): The situation when a private owner builds an infrastructure facility, transfers it to another entity and then operates it on a contractual basis for a specified period.

C&D: Construction and Demolition wastes generated by industry.

C&I: Commercial and Industry wastes generated by industry.

Calorific Value: The quantity of heat produced by fuel when completely combusted, expressed in joules per kilogram.

CAVE: Citizens against virtually anything.

CITEC: Committee of Technically Complex Systems.

Combustion: When material is burnt, combining oxygen to form heat, light and flame.

Composting: Controlled microbial degradation of non-hazardous organic waste yielding an environmentally sound product ('compost') with value as a soil amendment.

Digestion: The process of keeping material in contact with liquid to soften or disintegrate it.

Eco Recycle Victoria (ERV): Victorian Government Agency established to develop policy and strategies for the planning of waste service delivery.

EFT: Equivalent fulltime staff members.

EFW: Energy from wastes.

Energy Recovery: The process of extracting useful energy from waste, typically from the heat produced by incineration or via methane gas from landfills.

Environment Protection Authority (EPA): Victorian Government policy enforcement agency and regulator.

European Union (EU): Peak body of member countries established to deliver policy and directives for the delivery of waste management services.

Fluff: A form of refuse derived fuel.

Fluidized-Bed Incinerator: A type of incinerator made up of a vertical cylinder that contains a bed of sand held in suspension (fluidified) by high-velocity air injected through a grid at the base of the cylinder. The waste products are fed into and burned on the sand bed, which enhances the heat exchange process and supplies sufficient thermal inertia to the system to regulate the combustion process. The plant has extensive gas washing equipment and an energy recovery system.

Gasification: To convert to a gas.

Grate Incinerator: A type of incinerator in which waste is fed at the top part of an inclined stoker grate. The waste passes over the upper drying section where moisture is removed and descends into the lower burning section. Ash is removed at the lower part of the grate. Waste is burnt at an average temperature of 850°C. The plant has extensive gas washing equipment and an energy recovery system.

Green Dot Program: A programme by payments paid by manufacturers to a development board, which control an incentive scheme that subsidizes the recycling process dependant on the cities usage of products that are Green Dot approved.

Hazardous Waste: Solid, liquid, viscous or gaseous substance which, because of its source or measurable characteristics, is classified as potentially dangerous and is subject to specific legal regulations and special handling, shipping and disposal requirements.

IGCC: Integrated gasification combined cycle.

Incineration: Process of high-temperature combustion (between 850°C and 1200°C) in the presence of oxygen. Incineration is utilized to destroy waste and the hazardous constituents thereof.

Inert: Not chemical reactive, stable.

Institute Public Works Engineers Australia (IPWEA): Peak body with National and State divisions representing engineers engaged in Local Government.

International Solid Waste Association (ISWA): International peak body involved in the planning, policy development and dissemination of knowledge on waste industry activities.

ITS: Intelligent Transfer Station.

Key Performance Indicator (KPI): A measurement of a service activity or output.

Landfill (Category 1): Landfill licensed and approved to accept hazardous and prescribed wastes.

Landfill (Category 2): Landfill licensed to accept non-hazardous and organic wastes.

Landfill (Category 3): Landfill approved to accept inert wastes.

Landfill (Sanitary): An engineered method of disposing of solid waste on land, including sound siting, extensive site preparation (with clay and/or synthetic liners to prevent releases to ground water), proper leachate and gas management and monitoring, compaction, final cover, complete access control and record-keeping.

LCV: Low calorific value.

Leachate: Liquid which has moved through landfilled materials.

LGE: Local Government Engineer.

Mega Watt/Hour (MWH): A measurement of electrical energy.

Memorandum of Understanding (MOU): A document, which sets out the details, rules and agreed actions by parties to the agreement.

MRF: Municipal Waste Recovery Facility.

Methane: An odourless inflammable gas, formed from decaying organic matter. It has 21 times the greenhouse effect of carbon dioxide.

Municipal Engineering Foundation Victoria (MEFV): A foundation established to further the interests of Local Government Engineers in Victoria.

Municipal Solid Waste (MSW): A component of the Municipal waste stream generally comprising material that can be further treated prior to disposal of residues in landfill. Stream incorporates wastes generated in households and assimilated waste generated in commercial establishments, institutions and businesses. Includes used paper and cardboard, waste wood, plastic bottles, metal packaging and drink cartons, organic waste such as green waste, vegetable, fruit and garden waste and non-recyclable residual waste.

NGO: Non-Government Organisation.

NIMBY: Not in my back yard.

NIMFYE: Not in my front yard either.

Occupation Health and Safety (OH&S): Generally relates to the conditions under which staff and employees are engaged, and work in designated work places.

Packing Waste: Set of waste streams consisting of plastic bottles, metal packaging and drink cartons.

Pathogen: An organism that causes disease.

Percolator: A vessel that forces liquid through material often repetitively.

Physico-Chemical Treatment Unit: Processing unit providing in the neutralisation of acids and bases, the oxidation of cyanides, the reduction of chromates (mainly hexavalent chromium) and the immobilisation of heavy metals.

Pyrolysis: Decomposition by the action of heat.

Recovery: Processes for recovering usable materials by mechanical or manual separation and chemical or thermal separation processes.

Recycling: Process of sorting, cleansing, treating and reconstituting materials that would otherwise become solid waste, and returning them into material for new, reused, or reconstituted products that meet the quality standards necessary to be used in the marketplace.

Recycling Centre: Centre where discarded but re-usable goods such as furniture, cutlery, clothes, books and electronics are attracted in order to sell them to the public. The aim is to divert as much waste as possible from the final disposal to the recycling operation.

Refuse Derived Fuel (RDF): Generally a component of the waste stream separated and retained for use due to high calorific value of the material.

Regional Waste Management Group (RWMG): A group established by Government legislation to plan and educate the community on waste management matters. In Victoria composition can range from 3-15 member Councils.

Roasting Kiln: Type of incinerator used for the regeneration of hydrochloric acid.

SIWMP: Solid Industry Waste Management Plan.

Sludge: Matter of muddy consistency that sinks to the bottom of a liquid. In waste it is usually the sediment deposited during treatment of sewage.

Solidification: Adding cementitious materials (eg cement, lime, fly ash) to a liquid/semi-liquid wastestream to render it solid and limit the solubility of the hazardous constituents in a chemical and physical way.

Static Kiln: Type of incinerator, which is appropriate exclusively for liquid waste. Essentially it is a combustion chamber with no moving parts, into which the waste to be incinerated is fed. The plant has extensive gas washing equipment.

Syngas: A synthetic gas produced from pyrolysis oil.

Thermal: Adjective for heat or temperature.

Thin Film Evaporator: Processing unit used to recycle polluted solvents through evaporation.

Towards Zero Wastes (TZW): Generally refer to a strategy or review by the Victorian State Government of the operation and structure of the metropolitan region waste management groups.

UK: United Kingdom.

Victorian Civil Administrative Tribunal (VCAT): A body established to hear and determine disputes between parties and the issues of permits / approval and enforcement of statutes and regulations.

Waste Management Association Australia (WMAA): Is recognised as Australia's leading Association for waste management professionals. It represents individuals and corporates in the waste collection, transport and treatment industry, resource recovery and reprocessing, environmental consultants, as well as local and state government and academia.

Windrow: A heaped line or row of organic matter, which is used in the production of compost from organic mixed material.

1 Introduction

The Municipal Engineering Foundation Victoria (MEFV) granted awards to four engineers employed in Victorian Local Government Industry with a particular interest in the delivery of Waste Management Services.

The awards permitted the engineers to participate in the Waste Management Association Australia (WMAA) 2004 tour of Europe and attend the International Solid Waste Congress in Rome.

Joining the WMAA tour group allowed the awardees the opportunity to visit a number of waste treatment and recovery facilities, some using Alternative Waste Treatment Technologies in various European countries.

Selection of the awardees resulted from the calling of Expressions of Interest from municipalities across Victoria for Study Tour candidates with a particular interest in the future requirements likely to be encountered by local government in the delivery of waste services to the Community. The 2004 Study Tour awardees were:

Mr David Beard	Director Infrastructure Services City of Greater Bendigo
----------------	---

Mr Dimitri Scordalides	General Manager Infrastructure Benalla Rural City Council
------------------------	--

Mr Greg Scott	Assets Manager Mitchell Shire Council
---------------	--

Mr John Stamp	Manager, Project Management and Engineering Services Manningham City Council
---------------	--

Details of the WMAA 2004 European Tour participants are set out in Appendix 2.

2 Tour Objectives

A submission outlining the scope of the proposed 2004 Overseas Study Tour was prepared in conjunction with Waste Management Association of Australia.

The scope was further refined in consultation with members of the Municipal Engineering Foundation Victoria Board (MEFV) and with particular assistance of Mr Claude Cullino representing IPWEA Victoria on the MEFV Board.

The final submission, approved by the MEFV incorporated details of potential site visits, tour destinations and tour budget.

Identified objectives of the Study Tour required the awardees to increase the skills and information held on available Alternate Waste Treatment Technologies so that the knowledge may be transferred to others in the Local Government Engineering industry.

The tour objectives were:

- Obtain information on current and emerging landfill technology and practices.
- Review emerging trends and practices for the recovery and reduction of wastes entering landfill.
- Review and assess the effectiveness of the marketing and sale of value 'added' products from the waste stream.
- Assess the benefits and issues arising from the technologies available and their application to a Victorian environment.
- Review current and proposed legislation in Europe and its application to the delivery of waste services in Victoria.
- Review the papers presented at the Rome ISWA Congress.
- Review the role of the Local Government Engineer in the making of policy and regulations for the delivery of waste services.
- Develop contacts within the Waste Industry, which will enable ongoing networking on issues of interest to the industry.
- Be ambassadors and act in the interests of promoting the standing of the Local Government Engineer in the Waste Industry.

3 Methodology

The study tour comprised of 3 elements incorporating:

- Awardee participation on the 2004 WMAA. European tour of facilities in Italy, Switzerland, France, Belgium and Germany.
- A visit by David Beard to the Compact Power facility in Bristol, UK.
- Attendance of the awardees at the 2004 International Solid Waste Association Congress in Rome.

Prior to leaving for Europe the study tour group met and discussed the details of the tour, tour objectives and requirements for information to be obtained to produce a report on the findings of study tour.

3.1 WMAA Tour

The first stage of the tour was undertaken as part of the 2004 WMAA European tour which permitted the participants to visit a range of waste facilities as a group of a sufficient size to warrant senior personnel briefings at the various plant facilities.

The WMAA tour commenced in Venice, Italy and concluded in Rome over the period 2 October 2004 to 15 October 2004.

Details of the sites visited and information obtained are set out in Section 9 of this report. Additional information in regard to Waste to Energy Options, Legislation Issues and Community Values are set out in Sections 6, 7 and 8.

Issues arising from the site visits are discussed in Section 10.

3.2 UK Tour

David Beard had the opportunity to continue his travel to visit the Compact Power Facility in Bristol, UK. (Sponsored by the Calder Regional Waste Management Group and the City of Greater Bendigo). David has provided details of his findings on the visit in Section 9.6 of this report.

3.3 ISWA Congress

The study tour group also attended the 2004 International Solid Waste Association Congress in Rome during the period 17 October 2004 to 21 October 2004. Details of the ISWA Congress Paper Abstracts are set out in Appendix 3.

Highlights and relevant information gained is summarised in Section 11.

3.4 Outcomes

The opportunity to participate on the WMAA European Tour and subsequent attendance at the ISWA Congress has benefited the awardees and made us more aware of the issues involved in the introduction of AWT into the Australian Waste Management environment.

The conclusions reached and recommendations of the study group are set out in Sections 12 and 13 of this report.

4 Context

4.1 Waste Administration in Europe and Australia

Snapshot on European Waste Disposal

The average level of domestic recycling in the European Union is 26% but it varies considerably from one country to another (from 8% to 63%). There is an upward trend, and the same applies to recycling of packaging waste.

The average domestic waste incineration rate is 23%. However, incineration remains a little used option compared with re-use and recycling. Landfill of domestic waste remains the option chosen by many member countries, accounting for 45% on average. There is a downward trend.

Waste Administration and Service Delivery

Administration, Policy and Legislation development generally occur at relatively high levels of Government. It is important to note that common waste policy for the European Community is determined and adopted at European Union level with member nations determining local policy to enable compliance with EU directives.

This is a significant advance on the Australian model where each state and territory sets its own policies and legislation despite the commonalities and the relatively small population involved.

European Union

	Administration	Service Delivery
European Union General	<p>Directives (Legislation/Policy) Development by European Union.</p> <p>Legislation to meet EU Directives by member nations.</p>	<p>Local government provide/fund waste collection and disposal service through contracts or partnerships with private sector.</p> <p>Many AWT's have significant capital investment from higher levels of Government.</p>

Australia/Victoria

	Administration	Service Delivery
General Australian	Typically each state and territory determines its own waste policies and legislation.	Local Government delivers collection and disposal. Supported by State Agencies and Regional Waste Management Groups.
Victoria	Victorian State Government responsible for Waste Policy/Legislation: <ul style="list-style-type: none"> • Environment Protection Authority. • Eco Recycle Victoria. • Regional Waste Management Groups. 	State bodies assist in facilitation of services through research and funding.
	Local Government: <ul style="list-style-type: none"> • Local Policy. 	Domestic Waste Collection & Disposal. Domestic Recyclables Collection.

4.2 Emerging Industry Trends

Generally both in Europe and Australia there is an increasing focus on the treatment of organic wastes. Europe has a wide variety of systems for processing organic waste with significant Capital investment in the technologies, particularly with respect to enclosed facilities in comparison with Australia. Despite this relatively advanced position, Europe is still experiencing problems with product quality and market issues. Section 9 provides details of the range of specific organic waste treatment facilities, which were inspected as part of this tour.

The most significant difference to Australia are the European Waste to Energy technologies which are generally more widely accepted and therefore advanced in comparison to Australia. There are many examples of incineration as well as power plants and cement kilns fuelled by Refuse Derived Fuels. Section 9 provides details of the range of specific Waste to Energy waste treatment facilities which were inspected as part of this tour.

The table below shows that there is a limited number of waste treatment technologies which have not been trialled in some form in Australia. It is primarily the scale and the number of plants which differ between the two countries:

Technology	Waste Component	Systems Used Europe	Systems Used Australia
Waste Diversion	• Paper/Cardboard	X	X
	• Packaging	X	X
	• Garden Organics	X	X
	• Recyclable Packaging	X	X
	• Food Organic	X	X
	• Garden Organics	X	X
	• Construction and Demolition Waste	X	X

- In recent years the banning of the landfilling of bone meal due to “Mad Cow” Disease has provided a new and consistent fuel for power plants and cement kilns which has provided a new income stream and has contributed to the reduction in the purchase of traditional fuels.

Carbon Credits

Subsidy systems such as carbon credits and other such environmental offsets are important incentive schemes which can assist in reducing the operational costs of AWT facilities and not generally applicable to landfill operations.

These systems need to be further developed to encourage AWT's which provide more environmental outcomes and value adding, than simply diversion of waste from landfill.

4.4 Vision and Future Directions

The Vision for Waste Management in Europe is overall similar to that in Australia. A desire to reduce the impact from Waste on the environment, and the minimization of the production of waste.

The future directions of how this will be achieved is also similar however Australian timelines and actions are not as prescribed nor consistent.

A waste hierarchy promoting waste avoidance and reuse over disposal is a common basis to these visions and future directions.

EU Directives

Most legislation on waste management in Europe derives from European Union Directives.

Directives are instructions to the European Union's member states - currently fifteen countries - to alter or supplement their national laws by some specified time in order to achieve results within another specified time.

There are several stages in the policy process for the adoption of Directives.

First, the European Commission writes a working document showing an intention to propose a Directive. After discussion, the working document can become a draft proposal for a Directive. Then the Directive is proposed by the European Commission. Subsequently, it is examined by the European Parliament, the Council of the European Union (made up of relevant ministers, varying according to the subject discussed) and other institutions. It typically takes 2 to 4 years for a Directive to be adopted after it has been proposed. Once a Directive has been adopted, member states are required to implement it within a specified time - usually two years.

A number of these Directives are associated with the provision of common waste management objectives and systems across Europe.

Significant ones in the last 7 years include:

- Definition of waste.
- Hierarchy of principles of waste management.
- Waste management plans.
- Statistics on waste.
- Waste registers.
- Landfill of waste.

In addition a number of Directives associated with specific industries and material types have been adopted to reduce waste.

Australian

No common waste policies or legislation apply across Australia.

Victorian

The Victorian State Government develops and adopts waste policy and legislation.

Towards Zero Waste

The Victorian Government is committed to the goal of a sustainable Victoria. The Government's policy agenda highlights sustainable development, through the Growing Victoria Together, Melbourne 2030 and Victorian Greenhouse strategies which call for improvements in waste management to:

- Reduce the amount of waste generated (and associated greenhouse gas emissions).
- Ensure the state's resources are used as efficiently as possible.
- Encourage increased reuse and recycling of waste materials.

To deliver these goals, EcoRecycle Victoria, the State Government agency responsible for waste planning and promoting the sustainable use of resources, has developed a 10-year strategy, Towards Zero Waste: A Materials Efficiency Strategy for Victoria.

Towards Zero Waste proposes ambitious targets for reducing and recovery solid waste, which will require the establishment of new systems and infrastructure for managing wastes over the next decade. These initiatives will make tremendous improvements to Victoria's environmental performance.

4.5 Stakeholder Involvement/Ownership

Government

The Victorian Government oversees the planning and delivery of Waste Management Services in Victoria through the agencies of the Environmental Protection Authority Victoria (EPA Victoria), EcoRecycle, ERV, Association of Regional Waste Management Groups (RWMG's) constituted under the provisions of the Environment and Planning Act.

Government – EPA, ERV, Regions

The Environment Protection Authority Victoria (EPA Victoria) is a statutory body established under the Environment Protection Act 1970, in response to community concern about pollution. EPA Victoria's role is to administer the Act and the range of instruments it provides. These include state environment protection policies, waste management policies, works approvals, licences and environment improvement plans.

EcoRecycle Victoria (ERV) is a state government agency responsible for solid waste management, waste planning and promoting the sustainable use of resources.

EcoRecycle Victoria's role is to work in partnership with local government, business and industry, the community and schools to reduce waste. To deliver the goals of the Government's vision for a sustainable environment ERV has developed a strategy, *Toward Zero Waste: A materials Efficiency Strategy for Victoria*.

Regional Waste Management Groups (RWMGs) are responsible for the co-ordination of planning the management of municipal solid waste in Victoria. To coordinate and direct the waste management activities of its member councils, each RWMG produces a regional plan. The RWMGs also play a key role in educating the community about waste and environmental issues.

Local Government has an obligation to provide waste and recycling services to households. As the most direct link to the householders and in the expenditure for collection and disposal services it has an increasing role in waste minimisation and associated education.

5 Resources from Waste Materials

The most significant advance in recent times in the assessment of waste treatment facilities and systems has been the change in thinking of wastes as waste, to wastes being a resource. Consideration of the outputs from any system should now be focused on the recovery of materials and production of value added products prior to the adoption of a new technology, consideration needs to be given initially to the markets available to use the recovered product, then how the product range needs to be produced, and finally how the feedstock needs to be collected and from whom it is collected and how it is to be presented to the treatment/processing facility.

The following diagram gives an overview of how Municipal Solid Wastes (MSW) may be treated to obtain value added end products. Additional resources may also be obtained from the recyclables and organic components of the waste stream. In adopting an AWT technology consideration needs to be given to the highest and best use of the materials recovered from the waste stream.

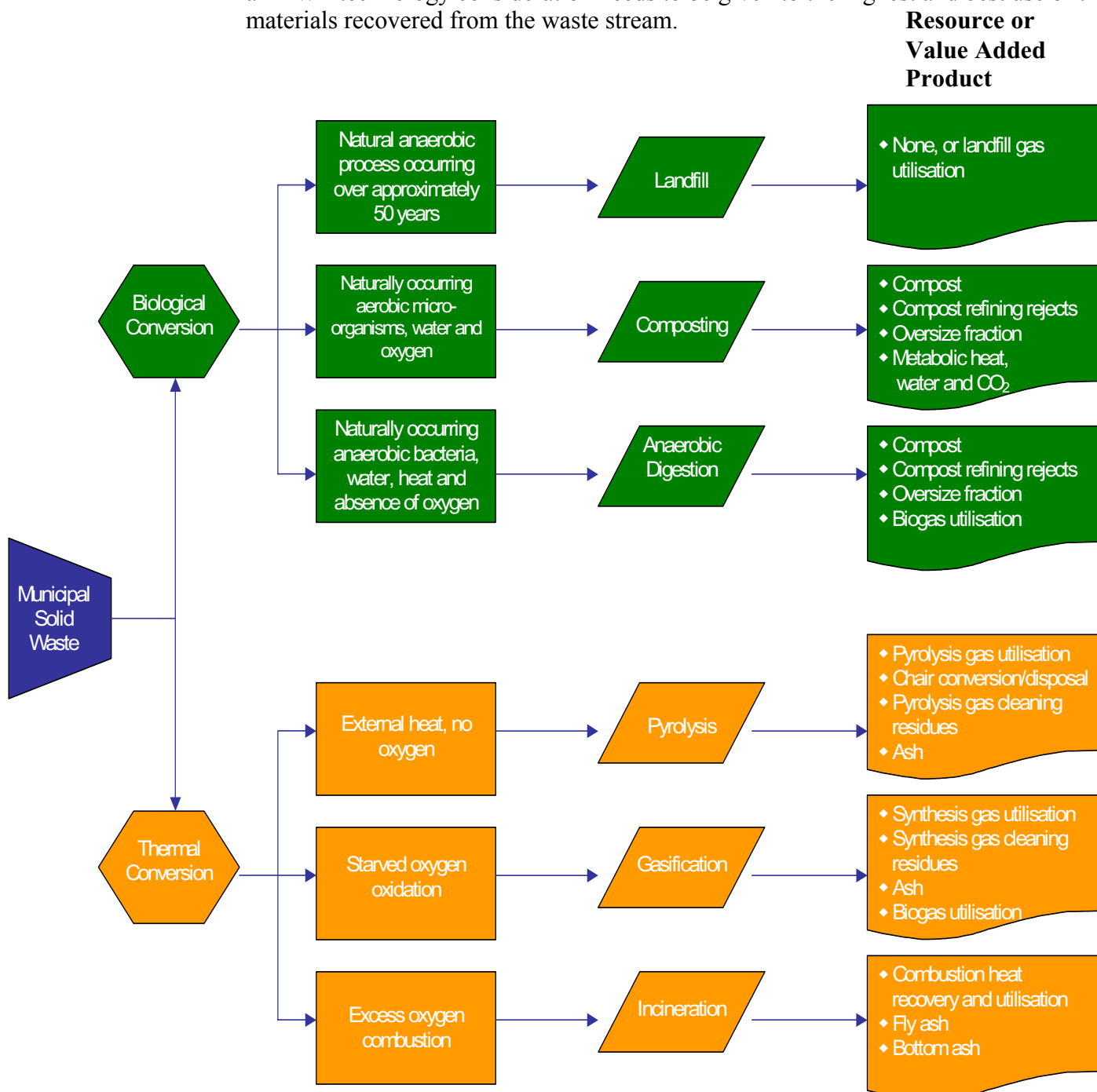

6 Waste to Energy Options

6.1 The Need for an Alternative to Landfill

Landfills are the traditional means of waste disposal and generally appear to be the most cost effective. However there are a number of issues relating to landfilling operations that make it an increasingly less viable option in today's society. This is compounded by stringent EPA requirements for the provision of financial assurances and levies and the increased cost of engineering solutions to prevent environmental impacts. Although landfilling has a relatively low cost initially, in the longer term there are potential high cost implications associated with environmental issues including methane emissions with high global warming potential and leachate and long term monitoring post closure.

Additionally, suitable sites for new landfills are becoming scarce or facing community opposition. Ultimately this means that landfilling is not necessarily the cheapest option when considered in the long term.

Waste to Energy projects can help to alleviate the pressure on landfills and utilise an otherwise neglected resource. Energy may be utilised locally in industry or converted to electricity and sold into the national electricity grid.

As the global population increases, management of industrial and municipal waste has evolved from being an environmental concern on a local level to an issue of national and even global proportion. In Australia over 14 million tonnes per annum of domestic and commercial solid waste is deposited into landfills making Australia one of the highest volume waste producers per capita in the world. In comparison, the UK in 1995 produced approximately 30 million tonnes of municipal solid waste.

The establishment, long term management and cost of landfill sites and waste disposal has led to research and development into technologies which convert waste to energy or by-products suitable for resale.

Waste to Energy technologies fall into two groups:

- **Biochemical Processes** - commonly producing compost as an end product, some also producing methane.
- **Thermal Technologies** - producing energy in the form of heat, hot waste or steam which may subsequently be converted to electricity.



Photo 102-0212
Composting Plant Vesta Spa Italy



Photo 102-0260
Thermal Incinerator EcoDeco Italy

6.2 Biochemical Processes

Biochemical conversion or digestion is a simple process whereby organic waste is broken down by the action of bacteria into molecules either aerobically or anaerobically. In addition to compost, aerobic digestion produces carbon dioxide and water vapour which is generally discharged to the atmosphere.

Anaerobic digestion produces a mixed gas predominantly made up of methane and carbon dioxide. The methane byproduct of anaerobic digestion can be combusted and used either to produce electricity or heat, thereby converting methane gas to carbon dioxide (which has a lower global warming potential) or be used in the production of alcohols.

Both aerobic and anaerobic decomposition are natural processes, which occur in landfills. The very early decomposition process in a landfill will be aerobic but this rapidly becomes anaerobic during the later, pethanogenic phase of decomposition. As the anaerobic processes are completed and source material decreases, the methane levels reduce allowing the landfill to become oxygenated and facilitate the aerobic decomposition processes.

Biochemical digestion processes seek to enhance the natural processes by either increasing the temperature or increasing the bacterial action (or both), thereby decreasing the time required for final degradation of the waste.

6.3 Terminology

The following definitions have been adopted from the *Australian Standard Composts, soil conditioners and mulches* (Standards Australia 1999):

- **Biosolids** (sewage sludge) – solid, semi-solid or slurry material produced by the treatment of urban sewage.
- **Compost** – pasteurised product which has undergone composting for a period of not less than 6 weeks, and which complies with the criteria specified in Table 2.1 of the Australian Standard AS 4454-1999.
- **Pasteurisation** – the process whereby organic materials are treated to kill plant and animal pathogens and weed propagules.

6.4 Aerobic Digestion

In aerobic digesters, aerobic conditions are maintained by blowing air at a controlled rate through a revolving drum containing waste material. This prevents the formation of anaerobic conditions and ensures that the degradation of organic wastes follows an aerobic path (and bypassing the methanogenic phase). After a period of time in the revolving drum, the waste is transferred to a maturation floor for a number of weeks. Aerobic conditions are maintained throughout the maturation phase through a variety of means such as mechanical turners or by blowing air through distributors in the floor.

6.5 Anaerobic Digestion

Anaerobic digestion is the decomposition of wet and green biomass through bacterial action in the absence of oxygen. This produces a mixed gas output of methane and carbon dioxide known as “biogas”.

Biogas can then be used as a substitute for fossil fuels to generate energy. Liquid waste, municipal waste and greenwaste can be used to produce biogas. There are a large variety of commercial processes, which utilise anaerobic digestion from small on-farm processing of animal husbandry by-products to large-scale landfill-type developments.

The breakdown of organic matter involves a number of biological steps during which bacteria absorb energy converting the gradually decomposing biomass to methane, carbon dioxide, water and compost.

The process is accelerated by placing waste in airtight containers known as digesters where the biogas can be captured for use.

Additionally odours are removed and the pollution potential of the waste is reduced.

New landfill sites can be specially developed in a configuration that encourages anaerobic digestion. In essence they are a controlled, enhanced biodegradation landfill. Gas extraction and leachate irrigation pipes are laid down as the waste is being deposited thus optimising the gas output and reducing the time for waste degradation. Gas output can be as high as 1000m³ per hour and last up to 20 years, which can be less than conventional landfills. Moisture levels in the waste are monitored and controlled.

Biogas can be burnt directly in thermal applications therefore displacing the need for natural gas in cooking and space heating or used in internal combustion engines or steam boilers to generate electricity.

The gas generally requires cleaning prior to use before it can be used as a direct substitute for natural gas.

6.6 Thermo-Chemical Processes

Thermal processing of organic waste materials can produce heat or a number of liquid or gaseous fuels.

There are three main options for recovering energy from solid waste:

- Production of refined fuels or refuse derived fuels (RDF) out of the main waste stream combustion in an incinerator or via pyrolysis or gasification techniques.
- Mass burn (combustion or direct incineration).
- Newer approaches involving recovery of combustible gases by gasification, pyrolysis and hydrogenation processes and/or reforming of the gases and oils produced.

Refuse Derived Fuels (RDF)

Typically waste with a high organic content after non-combustible and recyclable materials have been removed is suitable for conversion to RDF. Waste is sorted extensively to remove non-combustible components of the waste stream. The remainder is then shredded and then autoclaved (high pressure steam sterilisation) to sterilise the waste.

RDF processes involve compaction of the waste at high temperatures and pressures. The resulting product is briquetted, pelletised or 'fluffed' for power generation. Using this system of pre-processing and separation for power generation dramatically increases the efficiency of the waste to energy process but at a greatly increased cost due to the pre-processing of the waste.

Processing of the waste to RDF partially overcomes the problems of heterogeneity, moisture and ash and the fuel can then be used in incinerators.



Photo IMG-0044
Typical RDF Baled for transport

6.7 Direct Combustion or Incineration

Direct combustion or incineration is also described as mass burn or direct incineration. Direct combustion is the burning of waste to produce heat (as hot water or steam) or for electricity generation.



Photo IMG-0110
Incineration Chamber

Incineration reduces the amount of organic waste in municipal waste to about 5% of its original volume and sterilizes the hazardous components.

Mass burn is a typically low efficiency approach to energy production. While large amounts of waste are eliminated, municipal waste typically has a heat value of 8 to 12MJ/kg compared to 22MJ/kg for coal.

Additionally, the technology that must be applied for environmental control of emissions is costly. The mass burn, or RDF combustion and boiler system, provides the steam for electricity generation equipment. Because of a high corrosion in the boilers the steam temperature in these plants is less than 400°C and as a result their total steam efficiency is usually only between 12-24%. Additionally, due to the heterogeneous nature of municipal waste as well as its high ash and moisture content, conventional combustion equipment has to be adapted or specialised equipment designed. This makes the process a costly one.

Components of a typical mass burn incinerator:

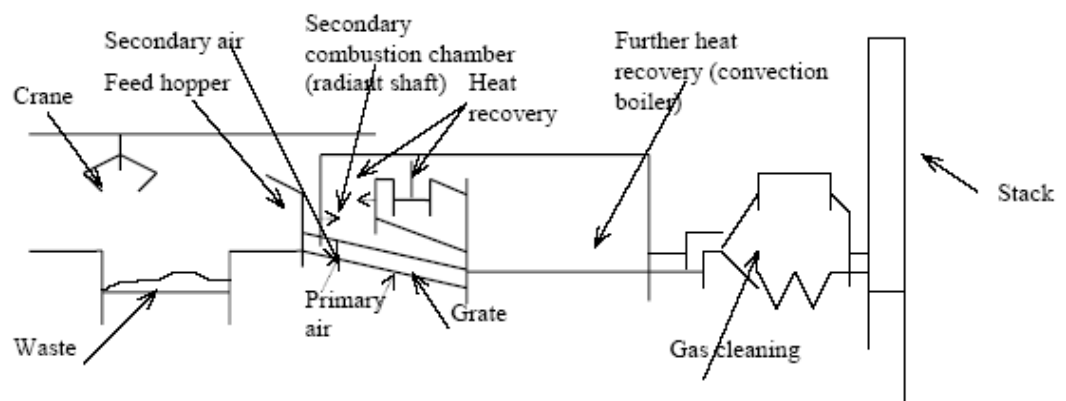

There are two types of incinerators:

- Grate incineration – mixed shredded waste is fed in via a charging chute. It is dried and ignited on the first grate and by the time it reaches the latter grate it is burnt out and leaves the furnace in the form of clinker. The incineration temperature is at a minimum of 950°C and the retention time in the after-burner should be a minimum of 2 seconds at a minimum of 850°C. At larger incinerators, the grate system is supplemented with a rotary kiln ensuring efficient burnout of all combustibles. The hot flue gases produced are led to a boiler plant for steam / hot water production.
- Fluidised bed incineration – these are in common use in Europe and are similar except that the waste is transported on a Optimizing sand bed which is created by blowing air upwards from under the sand bed. This allows oxygen to reach the combustible material more readily, increases the rate and efficiency of high moisture content fuels, and is adaptable to a variety of waste type fuels. Before leaving the boiler the flue gases are cleaned in a purification plant to remove heavy metals, acid gases and dioxins.

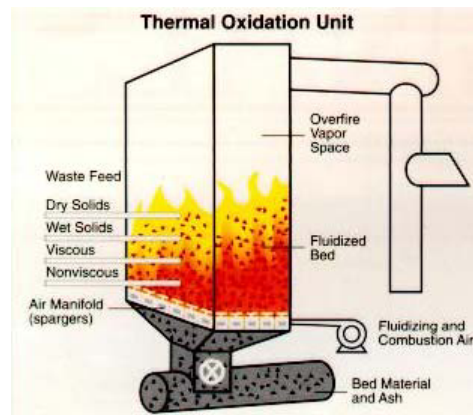

Diagram 1
Fluidized Bed

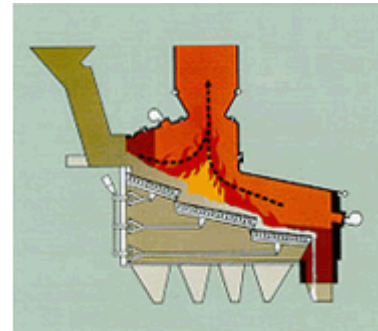

Diagram 2
Grate system

The following categories of pollutants are typically present in the flue gases before cleaning:

- Products of incomplete combustion (for example CO, various hydrocarbons (C_xH_y), free carbon).
- Particulates:
 - acid components (sulfur oxides (SO_x), nitrogen oxides (NO_x), hydrochloric acid (HCl), hydrogenfluoride (HF));
 - heavy metals (for example zinc (Zn), copper (Cu), lead (Pb), chromium (Cr), nickel (Ni), cadmium(Cd), mercury (Hg));
 - nitrogen oxides (NO_x); and
 - dioxins and furans.

Advantages

- All municipal waste and some Industrial wastes can be disposed unsorted.
- Volume reductions to 5-10% of the input waste mass primarily as an inert clinker which may be able to be used for road construction.
- All residues are sterile.
- Neutral energy requirements.
- Ash produced from the incineration process may be able to be sold on to the construction and road building industries to further reduce the waste material requiring disposal.

Disadvantages

- Little net energy recovery.
- Cost.
- Extensive flue cleaning system.
- Generation of fly ash and flue cleaning products (2-5% of incoming waste) may require disposal as hazardous waste.
- Generation of Nox and particulates and dioxins.

6.8 Pyrolysis

Pyrolysis is the thermal degradation of waste in the absence of air to produce char, pyrolysis oil, oil and pyrogas (frequently called syngas).

Pyrolysis is a thermochemical process for converting solid biomass into a more useful liquid or gaseous fuel. Waste is heated in the absence of oxygen, or partially combusted in a limited oxygen supply at temperatures between 350°C and 800°C. If the process temperature is 500°C or below the process is sometimes called thermolysis (or thermalysis). Pyrolysis produces a hydrocarbon rich gas mixture (pyrogas) by destructive distillation or thermo-cracking. The process leaves an inert residue containing carbon, ash, glass and non-oxidised metals and the gaseous pyrogas. If the pyrogas is allowed to cool a liquid consisting of hydrocarbon tars known as pyrolytic oil will form. The raw product gas is not suitable for operation of an internal combustion engine due to the high content of tar in the gas phase, which would condense before the gas entered the engine, however it can be combusted in specially designed chambers. This process can be a stand-alone process or can be undertaken in conjunction with gasification. The gaseous products of combustion of the pyrogas (at > 300°C) are normally led to a boiler plant for the production of steam or hot water.

Advantages

- Better retention of heavy metals in the char than in ash from combustion.
- Low leaching of heavy metals from the solid fraction.
- Production of gas with low calorific value (LCV), which can be combusted with low emissions.
- Neutral net energy requirements.
- Less flue gas produced than from incineration.
- Hydrochloric acid can be retained in or distilled from the solid residue.
- Lesser formation of dioxins or furans (unless cooled).
- Can handle difficult waste fractions.
- Production of sterile clinker and other residues.

Disadvantages

- Waste must be shredded or sorted before entering the unit.
- Unless the output is subsequently treated in a gasifier there is incomplete energy extraction and the pyrolytic oils/tars contain toxin and carcinogenic compounds.
- Relatively high cost.
- Back-up fuel supply is required at least during startup.

6.9 Gasification

Syngas is a combustible gas consisting primarily of hydrogen, carbon monoxide and hydrocarbons produced through the process of gasification. Gasification is a process of partial incineration with restricted air supply, which can be used to convert wastes into syngas. Coarsely shredded, sometimes pyrolysed waste, enters a gasifier where the carbonaceous material and fixed carbon reacts with a gasifying agent at temperatures between 800°C and 1100°C (1400°C-2000°C if using O₂). The gasified carbon forms a combustible gas mixture consisting of methane, carbon monoxide and carbon dioxide.

The resulting residue consists of a vitrified material resembling coarse sand (slag). Trace elements and other impurities are removed from the syngas and either recirculated or recovered. Sulfur is recovered in its elemental form or as sulfuric acid either of which is potentially marketable.

Syngas is typically used to produce electricity in an Integrated Gasification Combined Cycle (IGCC). It is understood that air emissions from the IGCC plants are far below US Clean Air Act standards and sulfur removal efficiencies of more than 99% are achievable. The IGCC also produces potentially marketable by-products such as fuels, chemicals, optimising or industrial gases.

The combustion of syngas results in a clean and high temperature gas that is very low in Nox, CO particulates and volatile organic compounds (VOCs). Additionally the gasification-syngas combustion process produces no smoke, odour, or undesirable gases.

When integrated with electricity production gasification can prove economically and environmentally attractive though it appears best suited to clean biomass as the input waste stream. The syngas can be converted to methanol, synthetic gasoline or used directly as a natural gas substitute and even blended with it in a gas supply line.

Advantages

- High degree of energy recovery (up to 85%) and good use of waste as an energy resource (electricity gain of up to 25-35% is possible).
- Best retention of heavy metals in the ash compared to other thermal processes.
- Low leaching of heavy metals from deposits of the vitrified solid fraction.
- Production of sterile clinker and other residues.

- Production of gas with low calorific value, which can be combusted with low emissions.
- Produces less flue gas than incineration.
- Environmentally superior to some conventional fuels such as coal and fuel oil.
- Slag is inert and may be able to be used a variety of uses in construction and building industries so long as the metals are fixed.
- Gas cleaning systems can remove dust, hydrochloric acid (HCl), hydrogen fluoride (HF), sulfur dioxide (SO₂), nitrogen oxides (Nox) etc from flue gas.
- Well suited to contaminated wood.

Disadvantages

- Waste must be shredded or sorted before entering unit.
- Gas contains traces of tars containing toxic and carcinogenic compounds resulting in the need to recirculate or treat added water as chemical waste.
- Complicated gas clean up for use in vehicles.
- Combustion of the product generates nitrogen oxides (Nox).
- Solid residue may contain some unprocessed carbon in the ash.
- High cost.

7 Legislation Issues

7.1 Status of Infrastructure

EU Legislation and Regulation

Landfill Directive

The Directive aims prevent or reduce as far as possible negative effects on the environment from the landfilling of waste, by introducing stringent technical requirements for waste and landfills.

The Directive is intended to prevent or reduce the adverse effects of the landfill of waste on the environment, in particular on surface water, groundwater, soil, air and human health.

The Landfill Directive sets targets to reduce landfilling of biodegradable municipal waste to 75% of 1995 levels by 2006, 50% by 2009 and 35% by 2016. Countries heavily dependent on landfill, will be able to claim exemptions to delay meeting the targets by four years (2020).

The Directive also bans landfilling of whole tyres from 2003 and of shredded tyres from 2006.

Existing landfill sites need only comply with the Directive eight years after it is implemented in member states, i.e. 2009.

Proposed Directive on the Biological Treatment of Biological Waste

This Directive would aim to promote the biological treatment of biodegradable waste (i.e. composting, anaerobic digestion and spreading on land) to help meet the targets of the Landfill Directive.

The Directive would cover not only municipal and similar waste, but also biodegradable residues produced by the agricultural, food and drink, wood processing, paper, leather, textiles and packaging industries, including wastewater treatment sludges produced in these sectors along with sewage treatment processes.

The suggested hierarchy for managing biodegradable waste (or biowaste) is as follows:

- Prevention or reduction of biowaste generation and contamination by pollutants.
- Reuse of biowaste such as cardboard.
- Recycling of separately collected wastes into the original material (such as paper or cardboard) whenever environmentally justified.
- Composting or anaerobic digestion of separately collected biowaste, that is not recycled into the original material, with the utilisation of compost or digestate for agricultural benefit or ecological improvement.

- Mechanical/biological treatment of biowaste.
- Use of biowaste as a source for generating energy.

Composting and anaerobic digestion would have to be carried out in ways that minimise air emissions and leaching. As for spreading on land, only treated biowaste would be allowed, except for those untreated biowastes such as uncontaminated organic wastes, and vegetable plant waste generated and remaining on agricultural or forest land.

Incineration Directive

The Incineration Directive aims to reduce emissions to air, water and land from the incineration of non-hazardous wastes, through the extension of emission controls to and through the imposition of more stringent controls on municipal waste incineration plants.

The Directive also applies to a range of different types of plants: municipal waste, sewage sludge and clinical waste incinerators, plus a variety of less common and smaller plants, for example incinerators burning treated waste wood and waste oil, and co-incineration processes (including waste oils and tyres in cement kilns) and the combustion of wastes such as sewage sludge in conventional electricity generation plants.

Hierarchy of Principles of Waste Management

The hierarchy of principles is as follows: - prevention, recycling, energy recovery and safe disposal.

Waste Management Plans

The introduction by the Member States of waste management plans is an essential component of European Community waste management policy.

Statistics on Waste

The quality of data concerning waste will be improved with the implementation of Regulation on waste statistics. Problems inconsistent treatment of data and how waste treatment and disposal is recorded impacts on waste statistics and subsequent difficulties in ensuring that target s are achieved.

7.2 Victorian Legislation

Existing Legislation in Victoria

EPA Landfill BPEM, Siting and Management of Landfills.

Proposed Legislation in Victoria

Towards Zero Waste.

Solid Waste Reduction Program.

The following is an extract from EcoRecycle's Towards Zero Waste Strategy related to Solid Waste Reduction. This is one of a number of examples where Victorian Policy is generally moving in the Direction being set by the European Policy.

Program	Milestone and Timelines	Responsible Partners (Lead Agency in Bold)	Target Sectors
3.1 Continue enforcement of landfill policy, upgrading/closing landfills that do not meet best practice.	EPA to continue working towards implementation of financial assurances for all licenced landfills. EPA to work with RWMGs and local government towards the prioritised closure and rehabilitation of those unlicensed landfill sites posing an unacceptable environmental risk.	EPA <ul style="list-style-type: none"> • RWMGs • Local government • Private landfill operators 	All Sectors
3.2 Ensure local government owned landfill management is consistent with the principles of sustainable waste management.	By end 2005/2006: All local government owned landfills pricing services on a user-pays basis reflecting the full lifecycle costs of landfilling (including closure, rehabilitation and aftercare).	RWMGs <ul style="list-style-type: none"> • Local government 	All Sectors
3.3 Review landfill levy.	By end 2006/07: Review landfill levy arrangements post 2007/08.	EPA	All Sectors
3.4 Investigate landfill prohibitions for priority materials and products to support strategy targets.	2003/04 to 2012/13: Potential bans on priority materials and products: <ul style="list-style-type: none"> • Where viable markets are identified and there is an environmental hazard from their disposal to landfill. • To underpin product stewardship arrangements. 	EPA	All Sectors

Relevance of EU Legislation to Victoria

As indicated previously, EU Directives are designed to provide an overall Direction for its member nations who then prepare their own more specific legislation and policy to ensure that the Directives are met.

In principle the EU Directives and the European position on waste does not contradict the Australian or Victorian position on waste management.

8 Community Values

Kerbside Collection Systems

The study tour concentrated on waste treatment and disposal with only general observations being made with regards to collection systems.

Collection system in the European Countries visited varied and appeared to be limited by the physical logistics related to high-density living. The most common collection system was bulk disposal bins for mixed waste, recyclables and paper located in streets where householder deposited their material.

It did not appear that other systems were not supported by any particular sector.

Waste Treatment Systems

The principles and in fact the drivers behind many of the emerging waste treatment technologies generally aim to produce outcomes for waste materials that are higher in the waste hierarchy.

In view of this it is suggested that as they meet Government policy objectives, they would in principle be supported by Government sectors.

However, despite meeting policy objectives, some technologies or systems may still receive lesser support or even opposition from NGO's or the community.

Some examples of this include:

Incineration - where although Government and the Community in the Countries visited appeared to support this technology, it appears that globally environmental organisations are opposed to this technology based on concerns related to emissions and issues related to better use of materials.

Technologies such as incineration may be more acceptable to governments and communities who already have similar technologies in place and new facilities are an improvement on existing. In many of these countries more controversial facilities such as nuclear power plants have been operating in close proximity to populated areas for many years.

In Australia, major treatment facilities are not in place and community is very sensitive to new technologies, which may impact on the environment and their health.

The Australian issues with successful development of controversial facilities is illustrated by:

- Difficulties with new nuclear reactor proposal for medical purposes in NSW.
- Commonwealth Government attempts to provide radioactive waste disposal facility.
- Recent failures of incinerator proposals in Tasmania and Western Australia (Refer Appendix 5).

- Difficulties in siting a hazardous waste storage facility in Victoria.
- Recent VCAT refusal of planning permit for a Biodiesel production plant in Wodonga, Victoria.

Community Opposition to Waste Facilities

It is clear that a common issue in both Europe and Australia is the growing trend by the community to oppose development proposals in a co-ordinated manner (with the workshop ISWA Technologies and Consensus “A problem to solve”) highlighted this issue.

NIMBY (Not In My Back Yard) with its many other forms NIMFYE (Not In My Front Yard Either), BANANA (Build Absolutely Nothing Anywhere Near Anybody) and its proponents CAVE (Citizens Against Virtually Anything) are a significant issue, which face all waste management proposals.

Communication technologies such as the internet provide individuals with the ability to research and mount significant opposition campaigns.

WASTE COLLECTION SYSTEMS		
Technology		Perceived Support for Technology in Australia
Kerbside Collections	Source separated at kerb	General acceptance.
	Commingled collections separated at treatment facility	General acceptance.
Drop-Off Facilities	Separation of materials at facility	General acceptance.
WASTE TREATMENT SYSTEMS		
Technology		Perceived Support for Technology in Australia
AWT	Diversion of waste from landfill	General acceptance of principle, cost issues for industry.
	Recovery of resources from waste stream	General acceptance.
Mechanical Separation Technologies	Materials Sorting	General acceptance.
	Waste Separation	

Biological Technologies	Land Application	Environmental impact issues based on location.
	Vermiculture	Acceptance in principle - siting issues.
	Open Windrow Composting	Acceptance in principle - siting issues.
	Enclosed Composting	Acceptance in principle - siting issues.
	Anaerobic Digestion	Acceptance in principle - siting issues.
Mechanical Biological Treatment		Acceptance in principle - siting issues.
Thermal Technologies	Incineration	Serious environmental and health issues which need to be overcome address NGO and community concerns.
	Pyrolysis/Gasification	Acceptance in principle, emission control and siting issues.
Landfill Technologies	Conventional – ‘Dry-Tomb’	General acceptance - siting issues.
	Bioreactor	General acceptance - siting issues.

Physical Differences – Population/Climate/Demographics

It is important when comparing Countries or even Continents the various physical issues which may impact on the technologies or policies chosen.

These factors can significantly influence the applicability or viability of systems.

Primarily the notable difference is the population densities. The large number of people within smaller land areas has resulted in high volume and enclosed treatment systems.

Limited land availability, surface water catchment issues and high ground water quality have placed pressure on the continued development of Landfill.

Transportation costs per capita are significantly less due to population density, whilst the high-density living provides logistical collection difficulties, which must be overcome. High density living also impacts on the waste stream characteristics with reduced garden organic waste generation per capita.

It should be noted that although population densities are generally high in Europe with its many large cities, Australian capital cities are of population sizes and densities that could support many of the technologies that are available in Europe from a waste volume perspective. Some Australian regional centres also have the potential to sustain some of the Alternative Waste Technologies.

Differences between Europe and Australia Waste Environments are set out in Appendix 1.

The following table provides a general comparison between Australian Population densities and those of the European countries visited:

	Total Area sq kilometres	Total Population	Density People sq kilometre
Germany	357868	82,425,000	230
Belgium	30520	10,350,000	340
Switzerland	41293	7,450,000	180
Italy	301245	58,060,000	193
France	543965	60,425,000	111
Australia	7682300	19,900,000	3
Victoria	237629	5,000,000	22

9 Waste Facilities Visited

A summary of the sites and facilities visited as part of the WMAA 2004 Tour are set out in Appendix 4.

9.1 Italy

9.1.1 Vesta Spa

Day	Site	Contact	Address
Mon Oct 4	Vesta Spa	Francesca Faraon Gianni Teardo	Via della Geologia 31 (Fusina Industrial Area) Fusina ITALY



Background

The plant is located in Fusina near Venice and services a population of 320,000 from 3 Cities, Venice, Marcan and Quarto Deltanre.

The breakdown of waste separation is as follows:

- 10% - Landfill.
- 30% - Composting.
- 50% - RDF.
- 10% - Recycling.

In preparing the tender for what plant the community wanted it was determined that it should be:

1. Modern and utilise state of the art technology.
2. Be located in an industrial area.
3. Utilize canal based transport as well as road based.



Old Venice Barge Unloading Conveyor (Garbage & Goods)

Incineration Pre-treatment (RDF)

The Incineration line handles 55,000 tonnes per annum. The waste is treated in bio-boxes as shown below where a crane grab lift moves the waste throughout the system where the waste is dried. The system takes approximately 5 days to pre-treat the waste and turn it into RDF. At the end of the process there is a 30% reduction in weight/volume (This then reduces the transport costs to the Incinerator). It was noted that the product is better with a reduced organic component as the drying takes considerably longer with higher organic content. The calorific value of the RDF at the completion of the process is four times that of normal refuse.



Bio Boxes



Grab Crane

The air treatment system is what is known as the LARA system which is explained below:

- The biological treatment of municipal solid waste generates an exhaust air rich in total organic carbon (“TOC”) along with a lot of chemical compounds, which cannot be completely removed with a simple bio-filter.
- An effective limitation of TOC concentrations is achieved by using a thermal oxidizer, which oxidises the organic compounds in a combustion chamber to carbon dioxide and water vapour. To reduce the operating costs, maximum heat recovery is achieved using ceramic heat exchangers with catalytic properties, which are located in three chambers. Up to 98 % of the process heat is recovered with this technique. Clean air contents of < 5 mg TOC/m³ waste air can be guaranteed.
- The process was developed by Herhof and it was the first time that a system like this was used in a biological waste treatment plant and is recognised as state of the art air treatment.

Further information on the treatment system can be found at http://www.herhofenvironmental.com/mbt/system_lara.asp.



Lara Air Treatment System

The material after treatment is baled and transported to the incineration plant.



Final RDF Product



Baled Product

Composting Plant

The plant receives green waste, which is a mix of biodegradable material and plastic bags (which green waste is contained in from collection points).

The green waste has a simple processing technique as follows:

- Delivered via trucks to a mixing area.
- Mixing via loader to get a reasonable blend.
- Shredded.
- Placed in a bio-box system.
- Reaction accelerated via a computerized bio-oxidation system.

Fresh compost is produced within 5 days screened to remove plastic content and left to cure for 1 month.

The air treatment system is a LADA. Which utilises a controlled air.

The plant operates an 18-hour day with 3 shifts and has 30 staff including administration.



Delivery Area



Mixing



Treatment



Final Product

The compost is used for agricultural purposes.

Project Economics

- The project was funded under a BOOT scheme (Build own operate and Transfer).
- The RDF production plant capital cost was approximately A\$58 million.
- The Composting plant capital cost was A\$25 million.
- RDF production costs A\$125 per tonne.
- Incineration costs A\$183 per tonne.
- Composting production A\$125 per tonne.

Note: Collection costs are on top of production costs.

Discussion

The plant is highly technical and quite complex in nature as far a systemic processing is concerned with a lot of double handling.

The system is very reliant on very good kerbside recycling with contamination a real issue to contend with.

Materials are stockpiled onsite, which means there is a heavy reliance on continual throughput processing and any breakdowns do cause problems for the operators with a backlog of product occurring from time to time. There didn't appear to be any liquid issues however some condensation is collected and treated within the plants.

9.1.2 Ansaldo Energia Spa Verona

Day	Site	Contact	Address
Mon Oct 4	Ansaldo Energia Spa	Gernot Stangl	Verona ITALY



Background

The plant is located in Verona and treats domestic and industrial waste, the plant has mechanical pre-treatment and is capable of handling 40 tonnes of mixed domestic product per hour and is currently operating at 430 tonnes per day.

The plant services Verona and the wider province.

The objective of the plant was to warm the city and it was noted that the project became very political.

The site is approximately 500m x 520m and has no issues with buffers from other uses.

The process of waste treatment is as follows:

- Material delivered via various bulk haulage and smaller domestic servicing vehicles.
- Material fed through a tooth shredder 150-200mm pieces.
- Material sieved through an octagonal rotary trommel 15m in length with 80mm diameter holes.
- Refining of material undertaken by air separation:

- heavy material goes to landfill; and
- lighter material continues through process.
- Material then goes through a secondary shredder, which cuts material into 50mm pieces, which is termed 'fluff'.
- Metals are extracted.
- Material is then stored and finally.
- Pressed into briquettes to be used as RDF.



Delivery (Walking Floor)



Tooth Shredder



Rotary Sieve



Plant and Conveyor System



Fluff



Plant

Other Facts

- Bio-gas is burnt in the engines which run approx 12-15 hrs per day.
- Plant warms a quarter of the City (population 270,000) via electricity fed back into the grid and water heated from the furnace pumped to town.
- Density of fluff is 200kg/m² 150 tonnes per day is generated from Verona and approximately 100 – 150 tonnes per day is generated from the provinces.
- Approximately 35 – 45% of material that comes to the plant ultimately ends up at landfill.
- Plant operates three shifts per day and employs 75 people.
- Power produced.
- 22 MW Waste.
- 15 MW from Gas.
- 2 MW from Bio Gas.

Note: Plants/incinerators accept RDF in different forms such as baled, loose fluff or in this case briquette.

Project Economics

Plant capital cost A\$166 million.

25 year pay back period and is 100% owned by the councils. The water, Gas, Electricity and Waste companies run the plant on behalf of the Council, which is common throughout Europe.

Gate fee is approximately A\$150 per tonne.

Discussion

The plant currently receives approximately 75% of domestic material with the remaining 25% being collected as kerbside recycling and processed elsewhere. It was difficult to ascertain the arrangements concerning the plants management however it is primarily run by the parent company of Energia Spa with the capital cost being born by Councils and some interest from other companies/agencies as noted. The interesting factor in most of the plants viewed was the high volume of material that is diverted to landfill and the extremely high gate charges.

It was noted that the overall objective of the plant wasn't waste minimisation or treatment but more the need to reduce power generation costs. Thus the high waste component. Other plants had a lesser waste residual but the objective was waste treatment and disposal. The power was a bonus and in many cases only provided enough power to run the plant.

9.1.3 EcoDeco Spa (ITS)



Day	Site	Contact	Address
Tue Oct 5	EcoDeco Spa	Gabriella di Marzio Paolo Albergoni	ITS - Lodi EcoEnergia - Corteolona ITALY



Background

The EcoDeco Group has been active since the late 1970s, when it began assisting industrial enterprises in dealing with problems linked to a recently enacted environmental law regulating discharges, emissions and waste and identifying innovative solutions for the disposal of industrial by-products.

In the 1990s a serious emergency developed in Lombardy. Therefore in 1992 seeking to relieve this emergency situation, the Lombardy Regional Council adopted Regional Law No. 21/92, which made it possible to propose and build plants with innovative solutions in the municipal waste sector at the proposers own risk.

Never having dealt with urban waste before, EcoDeco was able to transfer its innovative approach and a number of technologies developed for industrial waste to the municipal waste sector. At its own risk it proposed a patented innovative process: the Biocubi process.

In the spring of 1996 the first two such plants went into operation at Corteolona and Giussago and have been treating the waste of 400,000 equal to 130.000 t/year. These plants, later named Intelligent Transfer Stations (ITS), proved extraordinarily acceptable to residents and provided the basis for a complete, innovative approach to recovery and disposal of the Residual Fraction of Municipal Solid Waste following recyclable-waste collection.

At the moment there are 6 operative ITS, serving more then 1.500.000 inhabitants, with an overall treatment capacity of 500.000 t/year of Municipal Solid Waste. Moreover there are many other initiatives for the realization of new ITS in Italy and abroad.

In the course of 2001 the Group embarked on a company reorganisation programme, completed in 2002, aimed at separating the municipal waste management activity carried out by the Sistema EcoDeco Group from the industrial waste management activity performed by the EcoDeco Group.

Since 2001 Sistema EcoDeco Spa operates in accordance with UNI EN ISO 9001:2000 with regards to "design, construction, assistance of waste treatment, recovery and disposal plants".

The first site visited was the Intelligent Transfer Station (ITS).

Intelligent Transfer Stations (ITS) are plants for the recovery of the Residual Fraction of Municipal Solid Waste after waste sorting. This result is achieved through a simple, innovative process patented by Sistema EcoDeco: the Biocubi process.

The plant processes 60,000 tonnes per year and was constructed in 1996. Recyclables are still separated at home and a separate kerbside collection exists.

The Process

In the Biocubi process the putrescible components in the Residual Fraction decompose aerobically, giving off the heat needed to dry and thermally sanitise the materials to be recovered. This bio-dried material is a new material whose dry components can be easily separated in accordance with material and energy needs and are easily transported to the final utilisation centres.

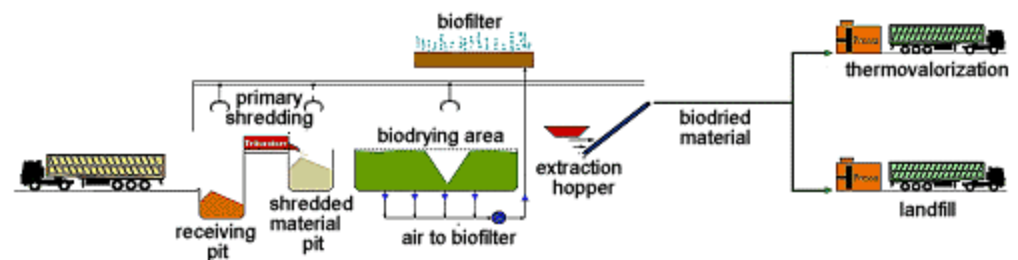

- Delivery via walking floor trucks and domestic vehicles:
 - water mist at door to keep flies in; and
 - negative pressure reduces dust and smell.
- Crane lifts and drops material into shredder.
- Grapping arm then drops into large holding area.
- Bio-drying area:
 - 14 days weight loss 25/30 %; and
 - hopper then to processing plant for treatment to RDF.
- Building operates under negative pressure.
 - fan sucks under floor.
- 15 –20 tonne/per hour.
- Of total product:
 - 2% leachate total;
 - 1% bio-filter; and
 - 1% waste.
- Plant operates 25 hrs/day.
- Shredder 8 hrs/day.
- Refining section 2 shifts of 8 hours.

- Shredder will cut off if iron comes in (large) Alarms and some visual checks control this system.
- Fire fighting system – water and foam gun.
- CO analyzer will detect combustion.
- Bio-filters are on the roof:
 - purifies air coming from process some temperature & moisture 39° and 10 % water;
 - bacteria destroy the odours and moisture is evaporated; and
 - bio-filter 4 years. The material is broken down into dirt and then has to be removed.

Processing

- trommel to remove the grit/sand;
- magnets to separate ferrous;
- eddy current non ferrous;
- wind sifter;
- remaining 18 kJ/kg has high calorific value;
- paper, plastic, derived organic fraction;
- another shredder 2 – 3 cm size. Single shaft with rotary cutters:
 - Need small pieces to flow into the head of furnace.
- transport in Fluff form:
 - 25 –26 tonne in transport.
 - Trailer used 12T Manufacture ADAMOLI.
 - Fluff is dropped into a bin the same size as the trailer then rammed into the transport. Walking floor to get out.



Holding/ Drying Bays



Bio Filter



Air Extraction Units



Transport

The Product

The output of the Biocubi process is a stabilised, bio-dried material that can be used as is or refined to suit the needs of the end user. The bio-dried material can be used as fuel in dedicated plants, cement kilns or plants integrated with thermal power stations (Waste & Power). In the absence of utilisation plants for energy generation, the bio-dried material can be used in the restoration of former landfill sites (Waste Carbon Sink) or disposed in single-use landfills with low environmental impact.



Advantages

- Moisture elimination, 25% weight loss, lower transport and final utilisation costs.
- Sanitised material and improved safety in subsequent operations.
- No direct contact between operator and waste contact thanks to automatic materials handling.
- Valorisation of local resources through integration of ITS plants with plants present in the user basin.
- Plant versatility with a view to future regulatory changes thanks to the structure's design for carrying out additional operations.
- Optimisation of performance with the centralised management assistance system World Manager.
- Minimisation of plant operating costs thanks to high plant automation and reduced manpower requirements.
- Limited area occupied with respect to traditional technologies.

- Safe storage capacity, useful if recovery or final disposal is temporarily impossible.

Other Pertinent Facts

- Company sells the plant technology.
- No restrictions on buffer distances.
- 50% Public Authority and 50% Company Public Private Ownership.
- 220,000 population serviced.
- 25% residual waste to landfill.
- 6 staff in bio-drying plant.

Project Economics

Bio-drying area Capital cost	A\$15 Million
Cost to run the plant	A\$167 per tonne
Cost to produce fluff is approx	A\$33 per tonne

Discussion

The plant was very impressive but again had very high capital and processing costs. The diversion to landfill was still high and the treatment of waste to produce a fluff was again based on achieving as high a calorific value as possible.

Kerbside recycling was still seen as the main driver for resource recovery with the remaining residual being fuel for incineration.

Plant TwoBackground

EcoDeco's secondary treatment plant is the incinerator. Fluff is transported in the trucks shown above to the incineration plant. This plant also disposes of sewerage sludge and has a total combined throughput of 60,000 tonnes per annum per line (two lines).

The fluff is transported via conveyor at a rate of 8 tonnes per hour to the incinerator furnace where it is burnt. The plant burns fairly clean with a purification system achieving low specification levels of Cl Acid. Steam is generated at 400 degrees C and flows at a rate of 40 tonne per hour.

Ash and sand/ grit residual is transferred to landfill.



Landfill at Rear of Plant



Plant

Each tonne of fluff represents approximately 19 kilojoules calorific value. This compares to brown coal at 21.1 kj/tonne and black coal at 18 kj/tonne.

9.2 Switzerland

Interlaken

Waste Facilities - Inspections

Mass Burn Incinerator



Day	Site	Contact	Address
Wed Oct 6	AVAG KVA AG	Marc Stammbach	Allmendstrasse 166 Thun SWITZERLAND

The Plant is situated in the township of Thun and services a population of 350,000 people from the surrounding area. In total the Plant services approximately 150 communities.

The Plant was commissioned in mid 2004 at a cost of approximately A\$230,000,000. It has a capacity of 100,000 tonnes per annum made up of 90,000 tonnes of garbage waste and 10,000 tonnes of sewerage sludge.



The whole Plant was ten years in the planning process and two years to be commissioned. It has an estimated 20 to 30 year life span. The facility is built on a site area of 5,000 square metres.

The Process

Commercial, Industrial and domestic waste is incinerated at the Plant to produce steam and electricity. 12MW of electricity can be generated at any time and placed into the grid. 46MW of thermal energy can also be generated. At present, a third of the city of Thun (approximately 15,000 people) receives the steam for heating purposes. The Plant can handle 13.5 tonnes per hour of refuse through the incineration process.



Loading dock

Waste is delivered to the facility from 7 transfer stations. Approximately 40% of the waste is transported by train using compaction units.

The only pre-treatment of waste relates to a rough shredding of commercial waste only. There is household recycling throughout Switzerland so many recyclables do not find their way into the waste.



Waste Grab

Waste collection within the township is carried out via a bag system, which are purchased and deposited in large bins at the end of streets. There is no cost for recyclables and therefore recycling is encouraged, thus reducing the overall cost to the residents. At present approximately 286 kilograms of waste per capita is received.

Air and water emissions from the site are continuously monitored. Slag from the incinerator is put to landfill as Switzerland is the only country that does not allow the slag to be used as a road base material.



Control Room

Project Economics

The Plant was built at a cost of approximately A\$230 million made up of A\$35 million community input, A\$75 million from Federal and State Governments and the balance from a Bank Consortium.

Gate fees for delivery at the site is A\$160 whereas through the transfer station system the cost is A\$250 per tonne.

Domestic waste is deposited via 40 litre bags purchased at a cost of A\$2. Approximately A\$200,000 per year is spent on education detailing the plant operations.

Discussion

There are no buffer requirements for the location of the plant, as it is located within an Industrial area.

Current landfill fees in Switzerland are in the order of A\$70 per tonne. This relates to construction site waste and not organic slag. Of this cost, A\$15 is to the Government.

With respect to Switzerland, 50% of electricity production is via nuclear power plants, 48% via hydro plants and 2% via the incineration of waste.

There are approximately twenty-five plants in total in Switzerland that operate on a similar system.

9.3 France

9.3.1 AZALYS

Waste to Energy Facility

Day	Site	Contact	Address
Thu Oct 7	AZALYS	Marie-Jo Lалуque	RD 190 Lieu dit "Les Bouveries" 78955 Carrieres Sous Poissy FRANCE

Work on the AZALYS Plant began in October 1996 and was completed on 15 December 1998. Design parameter for the facility included matters likely to evolve in the coming years such as population growth, the per capita production of waste, changing composition of waste and legislation. This information strongly influenced decisions, especially regarding the efficiency of the treatment method chosen.



Treatment Plant

The facility meets the most stringent standards on gas use emissions, especially those of the Netherlands.

The Plant handles 115,000 tonnes per year of domestic and assimilated waste. This tonnage breakdown is as follows:

- 85,000 tonnes domestic waste.
- 15,000 tonnes of waste from sorting and composting.
- 15,000 tonnes of non-classified industrial waste.

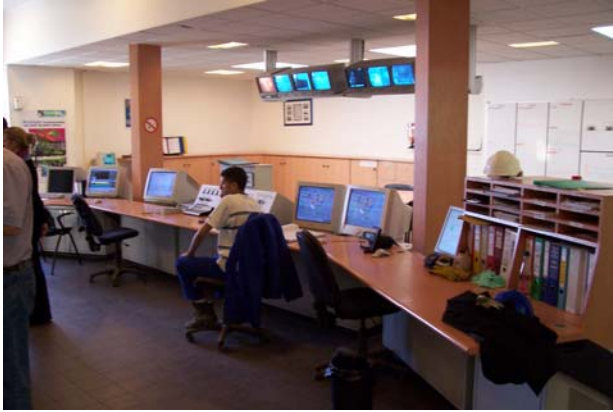

Control Room

The Plant operates continuously throughout the year including during maintenance periods. The Plant has 2 x 7.5 tonne per hour grate furnaces with a net lower heating value of 2,450 kcal/t of waste treated.

The energy released by combustion of the waste is recovered by two vertical water tube boilers in the form of super heated steam directed to a turbo generator producing 70,000 MWh/yr of electricity. This is distributed over the National Utility electricity grid.

The facility produces bi products as follows:

- 28,000 tonnes of bottom ash per year is produced. On removal of metals, the bottom ash is reused as back fill or road based material. The metals are recycled in the iron and steel industry.
- 2,500 tonnes of fly ash from the electrostatic filters at the boiler outlets. After neutralisation the fly ash is stabilised and sent to a category one landfill.
- 100,000 tonnes of sludge per year. Wet process scrubbing of combustion gases creates a requirement for thorough treatment of the water used after water treatment. Sludges are also stabilised and sent to a category one landfill.
- 3,000 tonnes of salt per year. A compliment to water treatment by evapoconcentration produces calcium chloride salt. The treated water is returned to the scrubbers in a closed circuit. There are therefore no liquid emissions off site.



Plant

Continuous monitoring of the gases emissions also occurs. Tests are done for total dust, carbon monoxide, carbon dioxide, oxygen, hydrochloric acid, sulphur dioxide, nitrogen oxides and ammonia. Regular measures carried out quarterly tests for hydrofluoric acid, total organic carbon, total metals, cadmium and mercury.

Discussion

The Plant employs 35 people and operates 24 hours per day. It generates 10MW of power of which 25% is used on site.

The emission controls meet the Dutch standards, which are considered to be 12 times higher than other standards within the world.

The facility serves a population of approximately 200,000 people covering 15 towns. It has been architecturally designed to fit into the surrounding land. The Plant cost approximately A\$160 million to build.



Transfer Station

9.3.2 SITA il de France Recycling Centre - Genevilliers

Day	Site	Contact	Address
Thu Oct 7	SITA il de France	Veronique Volat	Port de Genevilliers 21 Rue du Bassin 99230 Genevilliers FRANCE



Background

The Recycling centre (MRF) takes municipal collected kerbside material and C& I (Commercial and Industrial) and demolition waste. SITA has a range of treatment facilities and can handle all streams of waste.

- 12 landfills (Municipal).
- 3 landfills other waste.
- Incinerators.
- Operate different sorting plants and transfer stations for transport.
- Facility services north west of Paris.
- Has been operating 5- 6 years.
- Regulation has forced these plants to exist and they are continuing to grow.
- Aim is to avoid landfill and produce secondary production material.
- Transport is a high cost contributor.
- Sorting costs are now accepted by the market.
- Green dot on packaging means the company producing the product contributed to the recycling system.
- Recycling and green dot is being extended to all other goods such as tyres/batteries etc and this will finance the capital investments to sort.
- 300,000 tonnes/pa received with recovery of 50%.

- Strength is positioning of plant – ie direct access via Freeway & Rail & Boat.
- 3.5 Acres.
- Sorts 350 tonnes/pa.



- Currently services population of 1,000,000.
- 110 Staff (2) Two shifts Monday to Saturday. (10 Staff in Maintenance 3rd Shift).
- Work with social partners (long term un employed) to get people back to work.
- On each site a dedicated maintenance team.
- Contracts have been easy to procure due to two important factors being accessible road system and access by barge. The company's strengths are seen as a workforce adaptable to change, continuous improvement and high quality systems.

Project Economics

Whilst little information was available regarding the costing structure it was evident that the company was very profitable and the green dot system required the packaging companies to contribute to the cost of the process.

Discussion

Photographs couldn't be taken of the site however the ones shown were made available by the WMAA.

9.3.3 SITA il de France - Limeil Brevannes

MRF for Domestic Recyclables

Day	Site	Contact	Address
Fri Oct 8	SITA il de France (District)	Veronique Volat	Rue Ses Long Rideaux 94450 Limeil- Brevannes FRANCE

The plant is located in the district of Limeil Brevannes and handles domestic recyclables including packaging, paper, magazines, cardboard, etc. It services Paris City and surrounding provinces, a population of approximately 1,000,000. Products are accepted from registered agencies, local and private industry.



Part of Plant

Plant details are as follows:

- Situated on a 3-hectare site.
- Employs 36 staff.
- Cost of construction was not available.
- 2000 m² of the site is used for Transit.
- 3400 m² of the site is used for Delivery and Sorting.
- Operates 6am to 5pm Monday to Friday and 6am to 12pm Saturdays.
- Maintenance carried out at nights.

Types of material handled includes:

- 30,000 tonnes/year packaging.
- 12,000 tonnes/year newspapers and magazines.



Conveyor System

Plants operation is conveyor fed with a high level of manual sorting. Mechanical separation is carried out through trommels, magnets and visual light spectrometer, including air pressure separator to sorting basins.

Trucks are weighed on entering and leaving the site. When emptied a visual inspection is carried out on the material. If satisfactory it is stored for sorting. If not, the load is downgraded and a “non-conformance” sheet issued.

A spot check of 70kg of the material for each city is performed each month to help prioritise collection methods. This is also used to forecast workloads on conveyor systems and future climate. It also supports the “Green Dot” program.

9.3.4 Plessit – Gassot Landfill

Day	Site	Contact	Address
Fri Oct 8	REP 2000		CV1 entre RN16 et CD10 95720 Bouqueval FRANCE

The landfill is situated on a 250 hectare site, 50 hectares of which has been re-landscaped. It handles 1,100,000 tonnes of waste per year. It services Paris City and surrounding provinces, a population of approximately 1,000,000.



Landfill Plan

The facility employs 70 staff (including sand mining operation). Features of the site include:

- Landfill generates 10,000 cubic metres of bio-gas per hour. Gas collected via 500mm diameter pipes. 6 pumps also in network.
- Waste continually monitored. Radioactive detectors at Weigh Bridge.
- Waste delivered to transfer station. Special hydraulic lifts tilt larger trucks to 45 degree angle. Allows extra 3 to 4 m³ per truck.
- Company owns truck with a capacity of 140m³ to deliver waste to landfill face.
- 40 tonne blade compactors used at landfill face.



Weigh Bridge and delivery Dock

Cell construction consists of:

- 6 metre thick clay liner.
- 2mm HDPE liner.
- Leachate collection system, 50mm cover.



Cell Construction

As part of the burning process of the bio-gas, leachate generated for the site is also incinerated. Power plant generates 12MWh @ 11,000 Volts. Sufficient to power 30,000 households.



Gas Collection and Power Plant

9.3.5 CGECP Auror (Veolia Environment/Onyx)

Day	Site	Contact	Address
Fri Oct 8	CGECP Auror		Z1 des Bethunes Avenue du Feif 95310 Saint-ouen- L'Aumone FRANCE



Background

In 1989 there was the creation of the Association of Cities comprising 11 Cities with a population base of 200,000 people, which equated to approximately 100,000 tonnes per annum of waste.

The waste contract was first tendered in 1991 and the plant commissioned in 1996.

The company is 60% owned by Onyx with the balance evenly owned by local council and regional councils (50/50).

The company has a 25-year contract to receive and treat waste.

The plant has a capacity to treat 100,000 tonnes of MSW p.a. and 100,000 tonnes of special waste. Currently the plant is treating approximately:

Organics	21,000 tonnes per annum
Incineration	160,000 tonnes per annum
Non-Hazardous industrial	80,000 tonnes per annum

There is a household recycling collection which also generated approximately 16,000 tonnes per annum which is also processed through the plant.

Composting

Compost is produced over a three week period, the process is via windrowing with each row turned over every three days until it moves out into the holding area.

There exists an acid/ liquid treatment plant to deal with liquid waste that is generated and a bio- reactor treats the air.

80% of the compost is sold to farms and 20% is provided to the public for free.



Receival Bay Prior to Shred



Windrow Bay



Windrower



Final Product

Incineration

Little information was able to be gained at the site visit with respect to the incineration process however the following was retrieved from the Internet regarding the plant.

Name of the factory: CGECP AUROR' ENVIRONMENT
Member of the SVDU



General Presentation

Establishment: Machine CERGY PONTOISE

Address: Park of Activities Bétunes 2 - avenue of the Stronghold – LP 9
95310 Ouen Saint Alms - CERGY PONTOISE

Principal profit community: CERGY PONTOISE

Holder of the authorization to exploit: ONYX

Owner: ONYX - CGECP AUROR' ENVIRONMENT

Mode of exploitation: DSP

Types of treated waste:

- DIB (industrial Waste banals): Yes
- Household refuse and comparable: Yes
- Others: DAS

 **Technical Processes****Furnaces:**

- Furnace 1: Furnace CNIM
Type of furnace: Roast Martin
Capacity: 10,5 t/h (2200 kcal/kg)
Year of startup: 1995
- Furnace 2: Furnace CNIM
Type of furnace: Roast Martin
Capacity: 10,5 t/h (2200 kcal/kg)
Year of startup: 1995

Boilers:

- Boiler 1: Boiler CNIM
Type of boiler: Vertical
Flow: 30 t/h
Pressure: 41 bars ABS
Temperature: 390 °C
- Boiler 2: Boiler CNIM
Type of boiler: Vertical
Flow: 30 t/h
Pressure: 41 bars ABS
Temperature: 390 °C

Energy valorization: Electric: Harness of 7500 kw - Network Overheated Water - District heating

Treatments of the fume:

- Furnace 1: Treatment of the fume
Type of treatment: Wet process 1st stage - Alstom - with Filter Alstom Handle
Year of startup: 1995
- Furnace 2: Treatment of the fume
Type of treatment: Wet process 1st stage - Alstom - with Filter Alstom Handle
Year of startup: 1995

Treatment of the blast-furnace slags: Pretreatment blast-furnace slags: ferrous ore

Treatment of the REFIOM: C E T 1

Other treatments: Tri die and compost

 **Exploitation**

Annual tonnage of incinerated waste: 152300 T

Of which:

- **Tonnage of treated household refuse:** 143500 T
- **Tonnage of treated DIB:** 8800 T

Thermal energy production: 165 000 MWh

Production of electrical energy: 46 800 MWh

Thermal sale of energy: 165 000 MWh

Electric sale of power: 34 850 MWh

Valorization Matter

- **Tonnage developed blast-furnace slags:** 37 000 T
- **Tonnage ferrous metals:** 2 300 T

Certification: ISO 14000 - CLIS

Conformity: Regulation in force

Project Economics

The Global cost was: A\$122 Million

Onyx A\$69.3 Million

Regional Council A\$24.5 Million

Local Council A\$24.5 Million

ADEME A\$3.8 Million

9.3.6 Hersin Landfill



Day	Site	Contact	Address
Mon Oct 11	Hersin Landfill	Sylvain Daumy	SITA FD 62 530 Hersin Coupigny FRANCE

The landfill is situated on a 160 hectare site. 20 hectares of the site has already been capped. It handles approximately 600,000 tonnes of waste per year. In 2003, 591,935 tonnes of waste was placed in the landfill. It serves a population of approximately 1,000,000.

Details of the site include:

- Began operation in April 1977.
- Commercial waste accepted.
- Leachate stored and treated on-site.
- Bio-gas recovery scheduled for 8 to 12 years following closure.
- Licensed to 2032. Site to be fully rehabilitated and returned to community by 2062.
- Site employs 21 staff. Another 35 sub contractors also work on the site.
- 200 metre buffer distance around site.

Landfill operations:

- Trucks pass over a weigh bridge. The waste is identified and checked for radiation. Commercial loads checked from specific areas and may be refused if suspect. Trucks take waste to landfill face.



Site Office and Weigh Bridge

- Landfill cells cover an area of 3 hectares. Each cell can take 400,000 to 500,000 tonnes of waste. Height of landfill increases approximately 40 metres per year.



Landfill

- Stormwater controlled throughout site. Rainwater passes through settling ponds.
- Leachate collected and treated on-site. Main leachate drain is 600mm diameter, situated approximately 80 metres below waste. Treatment is by reverse osmosis, evaporation of brines and final discharge to an adjoining stream. Currently treating 48m³/hr, needs to treat 150m³/hr. Will be changing to an evaporation system utilising the bio-gas.



Leachate Ponds and Osmosis Treatment

- Bio-gas generated on-site equates to approximately 3,800 m³/hr. This is used in:
 - power generation 4.8 MW;
 - evaporation of brine; and
 - use in the SCORI Plant.

Waste delivered to the site is derived from the local area. The EU directive is that waste should be pre-treated before being placed in a landfill however this site accepts waste direct.

As part of placing waste, the landfill is overfilled approximately 10% to allow for settlement. Rehabilitation works take place between 3 to 5 years following the last filling to allow for the above settlement.

Rehabilitation is part of the permit condition for the operation of the landfill. 1.5 metres of material is placed over the cells and appropriate trees are planted. (Not a deep rooted variety) approximately 600,000 have already been planted on the site.

Costs

- Site costs A\$7.5 million to A\$11.5 million euro per year to operate.
- Revenue approximately A\$25 million.
- Gate price varies between A\$60 to A\$80 per tonne.

9.4 Belgium

9.4.1 Itradec Mons.

Day	Site	Contact	Address
Mon Oct 11	Itradec	Alexandre Urbain	Rue Du Champ De Shislage 1B 7021 Havre (Mons) BELGIUM

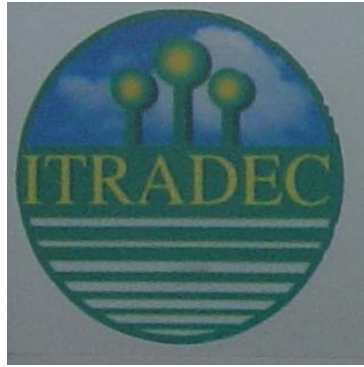

Background

The company is formed from an amalgam of 23 municipalities and only treats mixed waste, all other recyclables collected at kerbside is taken to a separate sorting facility. The population served is approximately 460,000. Prior to the establishment of Itradec all waste went to landfill.

Whilst the plant is a major sorting facility its prime objective is the stabilisation of waste prior to landfill.

The waste is delivered in bags, which through the process are split via a trommel containing knives.



Waste Delivery



Waste Holding Bays

The separation process then removes the iron and organic components to leave a residual that is deemed combustible (includes paper and plastics predominantly).

Separation of Ferris is via magnetic separation with a secondary drum separator for the organics. The first trommel has 65mm openings followed by the second trommel having 30mm up to 18mm.



Trommel and Magnetic Separate

The plastic and paper is shredded into small pieces and used as fuel in a nearby cement kiln.

The separable component makeup is as follows:

- Organic 35%
- Ferris 2-3%
- Mineral Fraction 12%
- Combustible paper and plastic 49%

In the treatment phase the two digesters used are capable of treating 60,000 tonnes/pa. The process is a natural one whereby water is added and controlled at 38 degrees C. The digestion process takes approximately one month to complete.

The gas coming off the system is made up of 60% Methane with the balance being Carbon Dioxide and Hydrogen Sulphide. The power created from the gas is capable of self-sustaining the plant with the remaining power sold back into the power grid. The plant runs a 21-hour day five days a week.

28,000 tonnes of organic material is fed into the system. For every one tonne of green waste 150 m3 of gas is generated which converts to 275 kwh of energy.



Digesters

Current staffing levels are 30 with two shifts of 15.

The sludge that is produced from the Bio Reactor is dewatered and stockpiled. All compost created is landfilled.

Project Economics

The composting digester cost	A\$28 million
The sorting equipment cost	A\$33 million
Operating cost is approx	A\$158 per tonne

The operating cost is paid for through taxes primarily via a bag system whereby a charge is placed on the purchase of bags, which are appropriately marked for collection.

9.4.2 Grammont – Biowaste Composting Facility

Day	Site	Contact	Address
Tue Oct 12	Grammont	Wim de Croo	Schendeldbeke Industrial Area Dagmoedstraat 105 B 9500 Geeraardsbergen BELGIUM

The facility is located on a 4 hectare site in Geeraardsbergen, Belgium, west of Brussels. The building covers 1 hectare of the site. The facility is owned 50% by SITA and 50% by INDAVER. It was specifically built to receive and treat organic material collected from the surrounding area in “grey” bins.

90% of material passing through the plant is from the domestic collection. This equates to approximately 100kg of material per household per year. The remaining 10% is from industry. At present 15,000 tonnes of compost is being produced per year.

Facility details include:

- Trucks are weighed upon entering and leaving. They are checked for radioactive material.



Site Office and Weigh Bridge

- Treatment of waste is covered by the costs charged to the community. The sale of compost is a bonus. 80% of compost produced sent to agriculture.
- 6 staff are employed at the plant.
- Total power usage of plant is 640 kWh.

Process

- Initial process consists of shredding, trommel separation and magnets. Material greater than 40mm disposed of at landfill.



Trommel

- Fermentation container measures 27m x 150m. The container is split into 8 cells. Material is stored in these cells and moved to the next cell each week. The cells floor has gaps to allow air to be blown through the waste (70,000 m³ /hr). Blocked air vents reduce the quality of the final compost product. Air and water speed up the fermentation process. 500 m³ of water used per month. Water is made up of recycled leachate from the site and topped up with town water.
- Average temperature of the material is 35 to 40°C, moisture content 90 – 95%.
- 120,000 m³ of air is evacuated from the building per hour and passed through a bio filter. Material in bio filter changed every 4 years.



Biofilter

Costs

- Plant cost approximately A\$21.5 million to build.
- Treatment costs A\$43 to A\$50 million.

9.5 Germany

9.5.1 Munster (MBT)

Rethmanns Group

Day	Site	Contact	Address
Wed Oct 13	MBT - Munster		Zum Heidehof 52 Munster GERMANY



Discussion

The plant visited was a residual waste treatment plant where recyclables were collected at kerbside and taken elsewhere for sorting and the residual waste treated whereby any ferries and recyclable material was recovered with the remaining fraction treated and land filled.

Technical information was not available and we were only permitted to photograph the outside of the building thus the summary of the site is quite short and further information could be obtained by contacting Rethmanns representatives in Australia.

The plant was quite complex with a large number of conveyors and sorting trommels, magnets etc to extract as much recyclable material as possible before the remaining organic and non recoverable fraction was treated and land filled.

When building the plant the community demanded a high level of technology and resource recovery as objectives. This was noted as coming at a cost and this is passed on via higher taxes.

The plant does not accept green waste and uses digesters to treat the organic fraction.

Approximately 60,000 tonnes per annum is delivered to the plant from the municipalities and the plant has an ultimate capacity of 100,000 tonnes.

The plant operates two shifts of 5 people per shift and 5 days per week.

At present 53% of the organic material goes to another site for treatment however a tunnel composting plant is currently under construction at the site which will then be able to handle all the material coming in.

The tunnel system is basically a series of inclosed chambers with walking floors within where organic material is stored for 6 weeks (rotated three times) and then removed and trucked to landfill as treated waste. The tunnels were 26m long and 6m wide.

Project Economics

Mechanical separation plant capital cost	A\$16.9 million
Tunnel composter capital cost	A\$28 million
Cities pay a gate fee of	A\$250 per tonne
Landfill fee paid by company	A\$108 per tonne
Incineration fee paid by company	A\$100 - \$150 per tonne

9.5.2 Beckum – Ready Mix Cement Kiln

Use of Refuse Derived Fuel (RDF)

Day	Site	Contact	Address
Wed Oct 13	ReadyMix Cement Kiln	Marc Stammbach	Beckum GERMANY

The plant produces approximately 850,000 tonnes of cement per year. In the production of the cement, the kiln is required to be heated to 2200°C. Through the process the material cools to 800°C at the end.



Cement Kiln

The cement kiln at Beckum uses the following fuels:

- 20,000 tonnes Refuse Derived Fuel (RDF).
- 15,000 tonnes Tyres.
- 40,000 tonnes Meat and Bone Meal.



RDF – Fluff and Shredded Tyres

With respect to the use of RDF, this produces a high chlorine content in the exhaust gases. This places a requirement on the plant to remove this from the gas, which makes the plant not as efficient.

The government monitors emissions from the plant and fuel stock used. The operator of the plant is currently paid to use the secondary fuel depending on the cost of landfill.

Emission controls are the same as for waste incinerators except for Sulphur Dioxide (SO₂) and Nitrous Oxides (NO_x).

9.5.3 Lippewerke (IRR)

Rethmanns Group

Day	Site	Contact	Address
Thu Oct 14	Lippewerke		Brunnestr. 38 Luenen GERMANY



Background

The site was extremely large and was an old industry factory, which was being modified to cater for a number of innovative recycling and resource recovery options.

The site featured:

- Company Head Office and Administration.
- Laboratory Services.
- Fluid Bed Incinerator for Solid and Liquid waste 90,000 tonnes per annum.
- Processing Plant for High Risk Meat and Food residuals 85,000 tonnes per annum.

- Substitute Fuel Generation Plant 35,000 tonnes per annum.
- Timber Processing 60,000 tonnes per annum.
- Automated Composting Plant for source separated Organic Waste 70,000 tonnes per annum.
- Animal Rendering Plant.
- Recycling of Flue Gas Cleaning Residues/Gypsum 250,000 tonnes per annum.
- Recycling of Metal slags 100,000 tonnes per annum.
- Reprocessing of Industrial Chemicals into Water Purifying Agents 30,000 tonnes per annum.
- Transfer Station.
- Landfill.

The tour of the facility was by bus so again it was difficult to gain an appreciation of each operation however we were able to view the organic waste treatment system in some detail. A summary of each production line is as follows:

Gypsum Plant

Gypsum is recovered and produced from the flue gas. The majority of the product is sold to the building industry and currently the plant generates 230,000 tonnes per annum.

In 2004 the company paid power plants for the product however as other gypsum plants have closed power plants are now paying Rethmanns to take the product.



Product

The Gypsum is also used to make a slurry through the Gypsum processing plant which operates at 1200 degrees C and the slurry produces the following products:

- Paint pigment (white).
- Paper additive.
- 600 tonnes of slurry is produced annually and the plant is capable of making 25,000 tonnes annually.

Rendering Plant

This plant takes waste primarily from slaughterhouses and the carcasses and offal is processed into a biological fuel, which is predominantly fat.

The fuel is then sold as a substitute for natural gas in incineration. Other uses for the fat are in cosmetic and soap products.

The product is not dried but is transported as slurry. The exhaust fumes from the bunker is also extracted and sent directly to the incinerator. The cycle is completed by the power plant steam being returned back to the rendering plant for sterilisation use.



Delivery Gates

Composting Plant

The composting facility services 9 councils with a population in the order of 750,000.

All organics are shredded and pressed into slabs then stacked into holding bays for the composting process. The complete process is automated. After 10 days of in vessel composting at 80 degrees C the cubes are then removed, broken up and screened into various products.

Currently 70,000 tonnes per year is treated at approximately 30 tonnes per hour.



Shredded Green Waste



Shredded Organics and Green Waste



Compressing Unit Producing Slabs



Composting Chamber



Composting Chamber



Final Product

The product sells for approximately A\$100 per tonne.

Metal Slag Recycling

In this part of the company metal is recovered from industry waste (slag). The slag is mixed with water to form slurry and circulated in a ball mill.

Approximately 90,000 tonnes per annum is treated and approximately 10,000 tonnes of metal is recovered.

The recovered metal is sold at a high market price back to industry.



Ball Mill

Wood Fuel Production

Timber is primarily bought in from sorted demolition material, pellets and industrial sources, mulched and used as an incineration fuel.



Raw Material



Final Product

Project Economics

The site utilised old existing building and in 1993 and A\$250 million was spent on putting modern plant and equipment into the facility.

The composting plant was in the order of A\$83 million to build.

9.5.4 Mark Elverslingsen Power Station

Fuel Substitute

Day	Site	Contact	Address
Thu Oct 14	Power Station Mark Elverslingsen	Marc Stammbach	Elverslingsen GERMANY

The site consists of three power stations, one of which utilises RDF and sewerage sludge. The plant has also used meat & bone meal.



Power Stations

Approximately 10,000 tonnes of alternate fuels used last year, which represents approximately 5% of the total heat requirement for the facility. Gas emissions are treated for removal of NO_x, SO₂ and Chlorine. Scrubbers are used for the removal of Sulphur and Chlorine.

Details of plant include:

- Sludge treated in fluidised bed type furnace. Coal and Sludge mixed and then added to Fluff (RDF).
- Industrial waste can be handled if no more than 12mm in size.
- Fluff also mixed with Coal and fed into 2 cyclonic burning chambers.
- Facility burns 3 – 4 tonnes of fluff per hour.
- Fuel generally transported with air in 100 – 150 diameter pipes.



RDF – Fluff and Sewerage Sludge

9.5.5 Frankfurt – RheinMain Biokompost

Anaerobic Digestion / Composting Plant

Day	Site	Contact	Address
Fri Oct 15	RheinMain Biokompost	Marc Stammbach	Peter Behrens Str. 8 Frankfurt am Main GERMANY

Since September 1999, the city of Frankfurt/Main recycles its biowaste in RheinMain Biokompost facility. It serves a population of 650,000. It is allegedly the most advanced waste treatment facility of its kind where fermentation and composting is combined in a single plant.

A combination of fermentation and composting techniques offers a high standard of waste disposal. Depending on the consistency of the feed material, composting or a combination of both processes is possible as a recycling process at this location. It makes the process independent from fluctuations in the composition and the consistency of the feed material.

The biogas created by the fermentation is also used to provide power for the plant. Any excess energy is fed to the power grid.

Process in general:

- Biowaste supplied to the plant is initially shredded and stripped of any metallic particles with the use of a magnetic separator.
- Subsequent removal of foreign objects by screening and additional grinding produces the optimum material size. Screen residual generally consists of non-compostable components.
- Moist low density biowaste from households is first sent to fermentation. Biowaste consisting of well structured plant and gardening waste is composted immediately.
- Composting material is aerobically degraded whereas fermentation proceeds anaerobically.

Flowchart of Combination Process

of the Biowaste Treatment Plant
of RMB Rhein-Main Biokompost GmbH

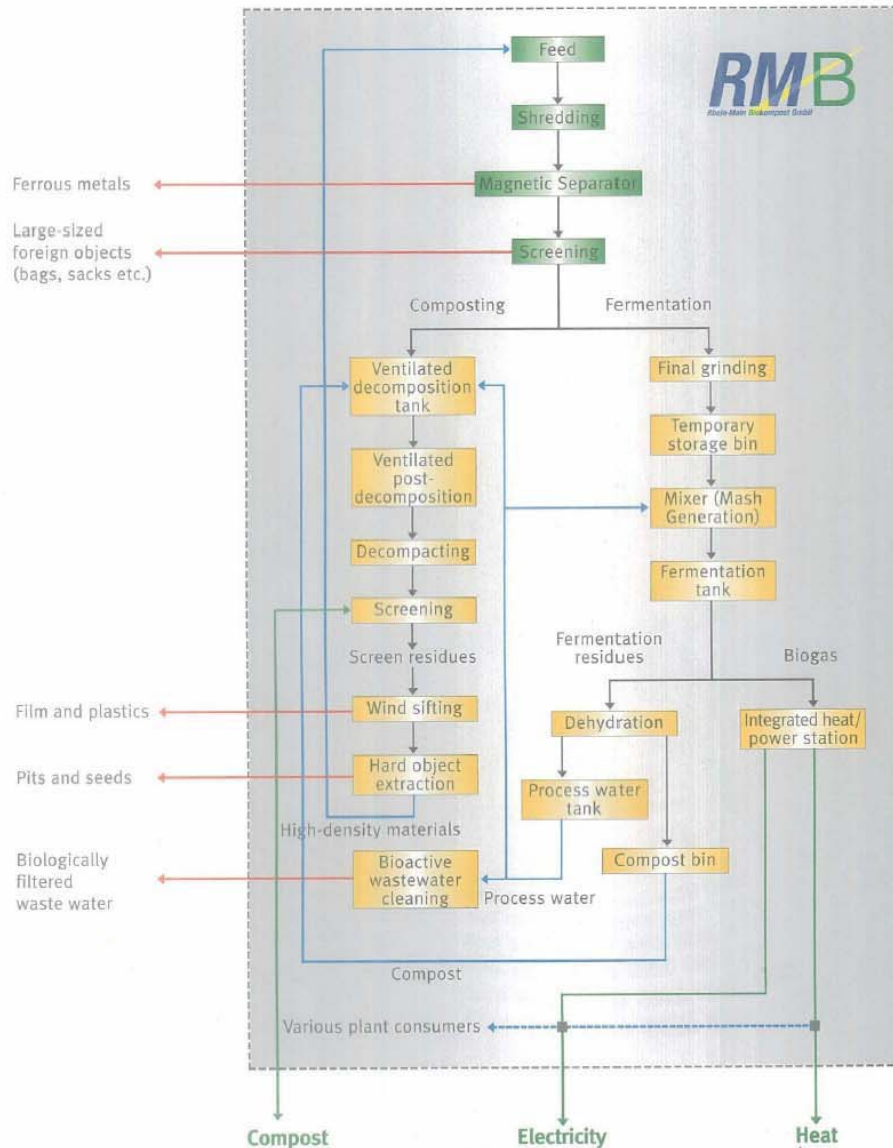

Monday, 7 March 2005.max

Fermentation

- Organic material initially stored in temporary bin until sufficient material accumulated to operate the plant.
- Material is ground with water in a mixer before being placed in the fermentation reactor. The thermophilic operating method requires a process temperature of 55-57°C.
- Material remains in the fermentation reactor for 3 weeks.

- Biogas generated is converted into electric and thermal energy in two integrated heat/power stations.
- Fermented mash is dehydrated via chamber filter presses and a high performance centrifuge.

Composting

- Material is carried by a conveyor belt into an airtight decomposition tunnel.
- A predefined quantity of air is passed through the material via a ventilation grill on the floor. Turning of the material is not necessary.
- Excess air is biologically filtered through an air washer and a biofilter and returned to the atmosphere through a chimney.
- Material is occasionally heated up to over 70°C.
- The material remains in the tunnel for 4 week.
- Compost placed on a ventilated post decomposition grill for final maturation.
- The fully matured compost is then ground and screened.
- The resulting compost is marketed under the RETERRA label.
- Plant details:
 - A\$25.7 million to build;
 - site are 2 hectares;
 - 10 staff employed on-site;
 - annual input 30,000 tonnes biodegradable waste;
 - approximately 15,000 cubic metres of compost produced;
 - 8,000 m³ of biogas per day. (Corresponds to the calorific power of 3,500 litres of heating oil or approximately 15,000 kWh); and
 - 1.7 million kWh of electric and thermal energy.

9.5.6 Frankfurt – FES Paper Sorting

Material Recycling Facility

Day	Site	Contact	Address
Fri Oct 15	FES Paper Sorting	Marc Stammbach	Schielestr 25 Frankfurt am Main GERMANY

Plant was opened in March 2003 and is considered the most modern and biggest in Europe. It was built as a private/public partnership with Frankfurt, Germany.

General information on plant:

- Plant can handle 120,000 tonnes of paper per year (last year 80,000 tonnes).
- 90% household paper, 10% industry.
- Produce is pressed bales and loose paper.
- 3 separations occur:
 - good quality white paper;
 - cardboard; and
 - mixed paper.
- Handles 60 truck deliveries per day, maximum 90-100.
- Flow rate maximum 30 tonnes per hour. Best working at 26-28 tonnes/hr.
- Sorting carried out by air and manually to remove cardboard and large portions.
- Automatic detectors take out plastics and left over cardboards.
- Manual sorting to remove remaining plastics and other contaminants.

Household contamination represents approximately 2% of the material collected. Household material collected via a bin system. They have 4 bins, one each for paper/cardboard, Waste, Organics and Plastic bottles/packaging. Tins and glass bottles are deposited at delivery stations.

9.6 Bristol UK - Compact Power



Hydro House
St Andrews Rd Avonmouth Bristol
BS11 9HZ

Chairman Nic Cooper +44(0)117 980 2909

n-cooper@compactpower.co.uk



Background

The plant at Avonmouth, Bristol is designed to accept 8,000 t/a of municipal and priority wastes such as scrap tyres and clinical waste. The plant consists of a combined pyrolysis and gasification unit with 3 pyrolysis tubes each capable of processing 500 kg/hr. A major advantage is the small size of the site with the entire facility contained in a building 40m x 40m.

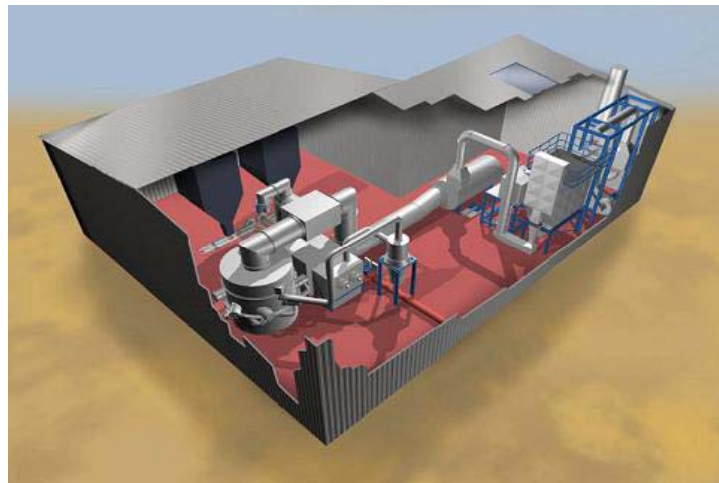

Cross Section Through Plant

The plant is a combination pyrolysis and thermal gasification plant including thermal combustion of the pyrogas and gasification products. The heat produced from the thermal combustion process drives a boiler producing process steam and ultimately power. Approximately 30% of the resultant energy is used to drive the process with the remainder available for sale. Steam is also used to heat the pyrolysis and gasification chambers.

The Process

The process is illustrated in Figure D1, D2.

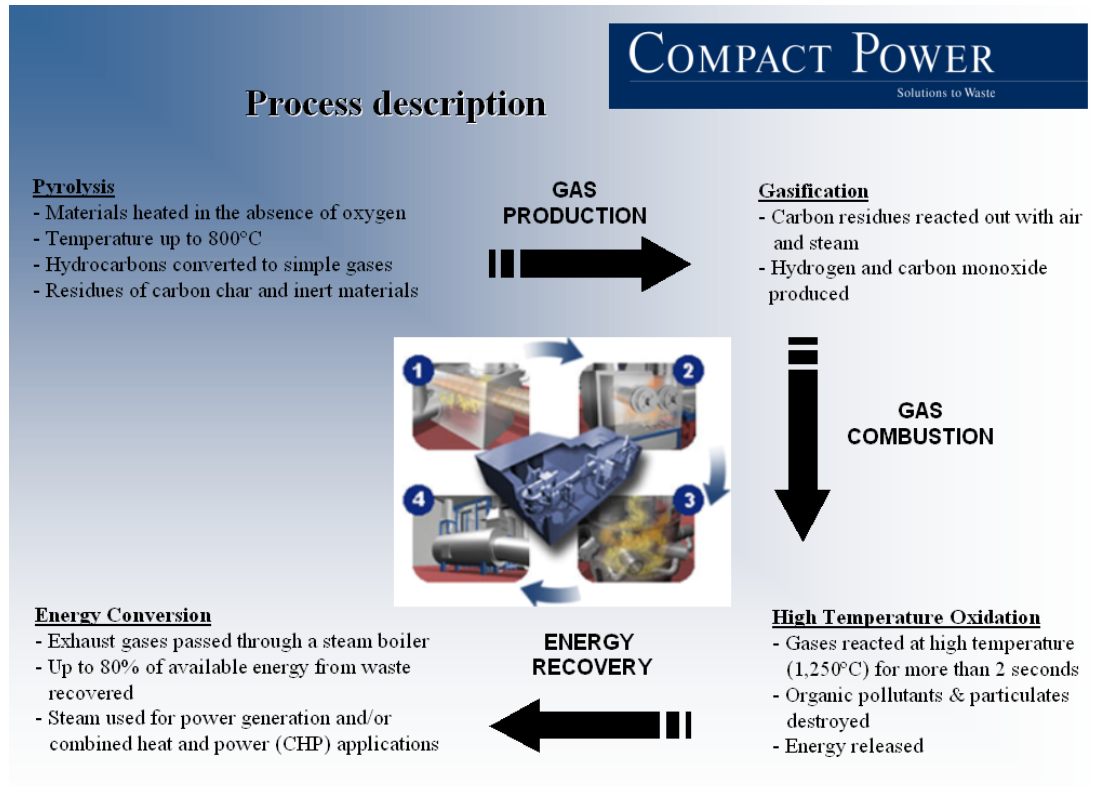

Figure D1

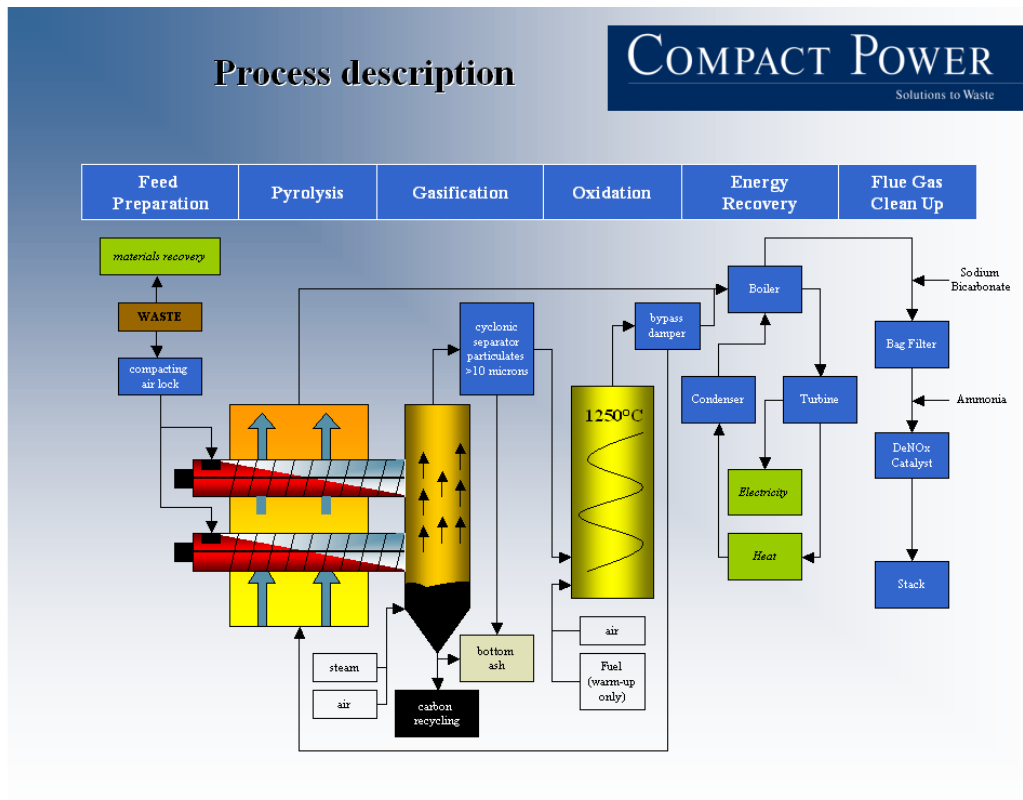

Figure D2

The incoming waste is shredded to pass through a 100mm sieve before being tipped into a hopper where it is fed into the pyrolysis chamber, excluding as much oxygen as possible. The material is fed into a system of tubes (chambers) where it remains for approximately 30 minutes. The temperature varies between 400oC to 800oC resulting in the breakdown of the organic materials hydrocarbon gases (pyrogas). This leaves carbon residues and inert materials such as ash, metals and glass, which then pass into the gasification chamber after approximately 1 hour. Steam is injected into the gasification chamber and this reacts with the residual carbon to produce hydrogen and carbon monoxide (both combustible) and carbon dioxide.

The gaseous products from the pyrolysis and gasification then pass into a thermal combustion unit where they are optimized through reactions with injected air. The temperature is maintained at 1250°C. The gases remain in this chamber for at least two seconds to ensure destruction of pollutants. The exhaust gases provide heat for the pyrolysis and gasification, and the process is self-sustaining even with wastes with a low calorific value.

The exhaust gases pass through a boiler where heat is converted to steam. The cooled gases then pass through a series of filters to reduce any residual dioxins and nitrogen oxides (Nox). Ash volumes will depend on the source material. Clinical waste ash volumes are reduced by 95% of the original volume.

Compared with a typical mass burn incinerator the system has a low environmental impact in terms of air pollution and discharges of residue to land. There is no aqueous waste effluent and the plant has a low visual impact compared with the typical mass burn incinerator.

The ability of the plant to process multiple waste streams simultaneously gives the potential for optimizing a total waste solution for the community. The technology can be combined with a sludge drying plant (DryVac) providing an economic solution for highly aqueous wastewater treatment. An integrated closed system returns clean water and valuable materials are recovered from the solid content.

One of the systems biggest advantages is its modularity as shown in Figure D3:

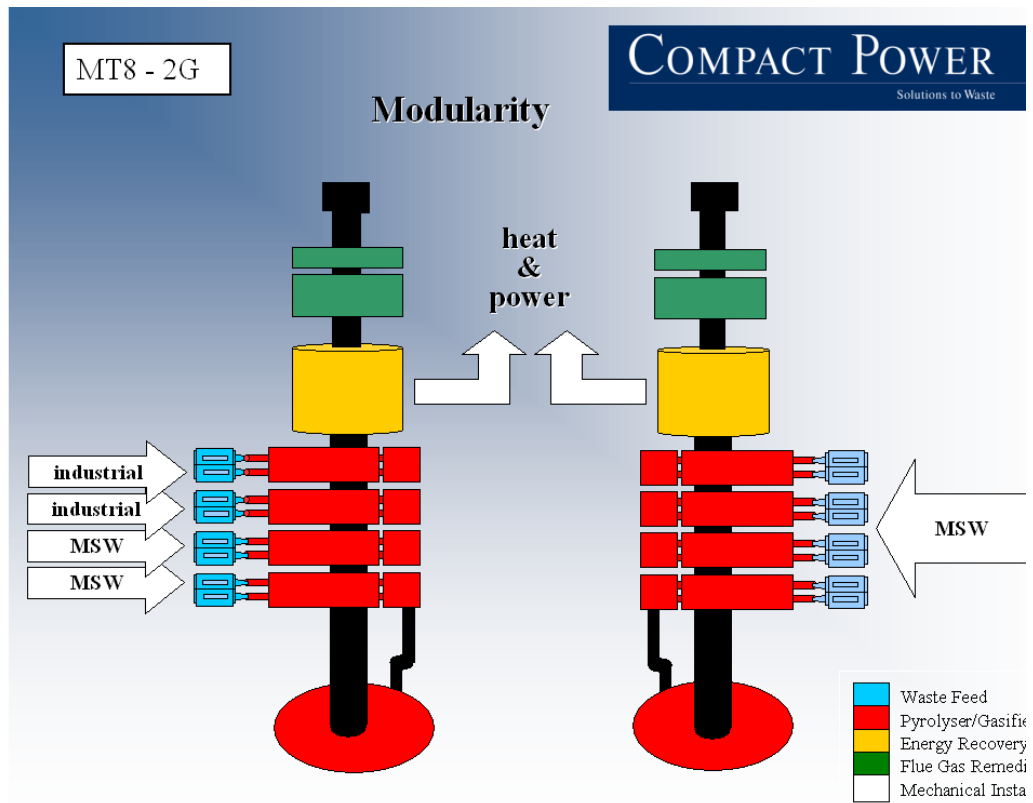

Figure D3

The emission levels are displayed on the companies website in real time and results are summarized in the table Figure D4 and D5:

COMPACT POWER
Solutions to Waste

Environmental Impact

mg/Nm ³ 11% O ₂ @ 273K & 101.3kPa	EU Directive Limits		Compact Power
	s: spot / d: daily	½ hour	
Particulates	10 (d)	30	0.2
VOC's as carbon	10 (d)	20	Trace
NO (NO + NO ₂)	200 (d)	400	<37
HCl	10 (d)	60	2
HF	1 (d)	4	<0.1
SO ₂	50 (d)	200	< 2.5
CO	50 (d)	150	Trace
Cd & Tl	0.05 (s)		0.006
Mercury	0.05 (s)		0.006
Pb Cr Cu Mn Ni As Sb Co V	0.5 (s)		0.006
^{Sn} Dioxins TEQ ng/Nm ³	0.1 (s)		<0.003
N ₂ O	30 (d)		Trace
NH ₃	10 (d)	20	< 1

Figure D4

Data for week 13/06/02

	HCl mg/m3		CO mg/m3		SO2 mg/m3		NOx mg/m3		VOC mg/m3		NH3 mg/m3		Particulate mg/m3	
	Day Avg.	Max 1/2hr	Day Avg.	Max 1/2hr	Day Avg.	Max 1/2hr	Day Avg.	Max 1/2hr	Day Avg.	Max 1/2hr	Day Avg.	Max 1/2hr	Day Avg.	Max 1/2hr
WID limit	10	60	50	100	50	200	200	400	10	20	10	20	10	30
Trial Avg.	0.91	1.73	1.45	20.74	0.34	3.22	30.3	61.5	0.34	2.1	0.29	0.83	2.13	4.7
% of WID	9.08	2.88	2.91	20.74	0.69	1.61	15.15	15.38	3.36	10.51	2.91	4.14	21.29	15.67
Trial day Max	3.05	4.42	2.86	58.67	1.25	13.06	33.89	89.86	0.39	7.57	0.45	1.82	2.44	12.66
% of WID	30.5	7.37	5.72	58.67	2.5	6.53	16.95	22.47	3.9	37.85	4.5	9.1	24.4	42.2
Trial day Min	0.24	0.58	0.26	1.94	0.05	0.76	24.58	42.68	0.3	0.66	0.19	0.4	1.75	3.09
% of WID	2.4	0.97	0.52	1.94	0.1	0.38	12.29	10.67	3	3.3	1.9	2	17.5	10.3

Figure D5

Project Economics

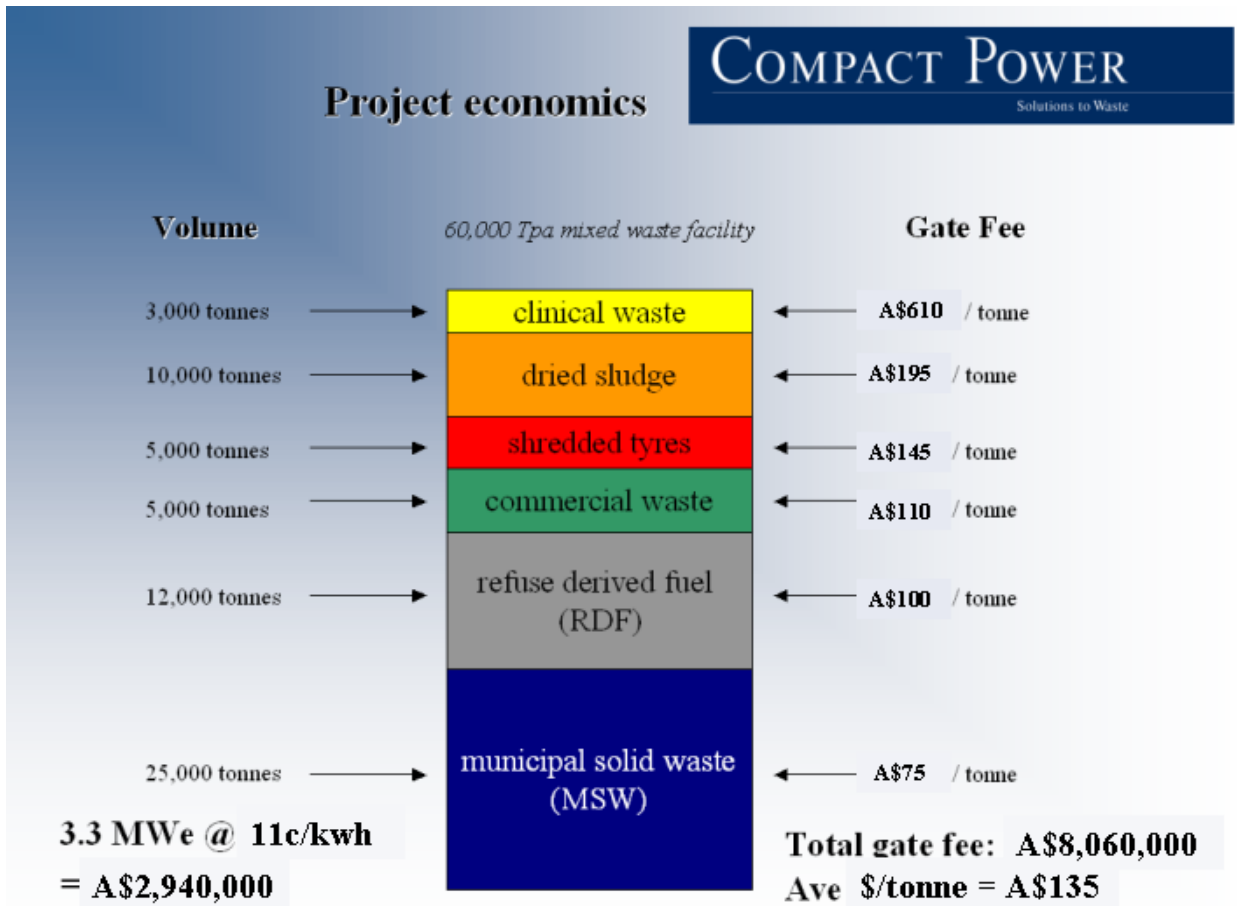

Not all waste is put through the gasification pyrolysis process. The low calorific value material is put through an autoclave system and landfilled as depicted in the flow diagram below:

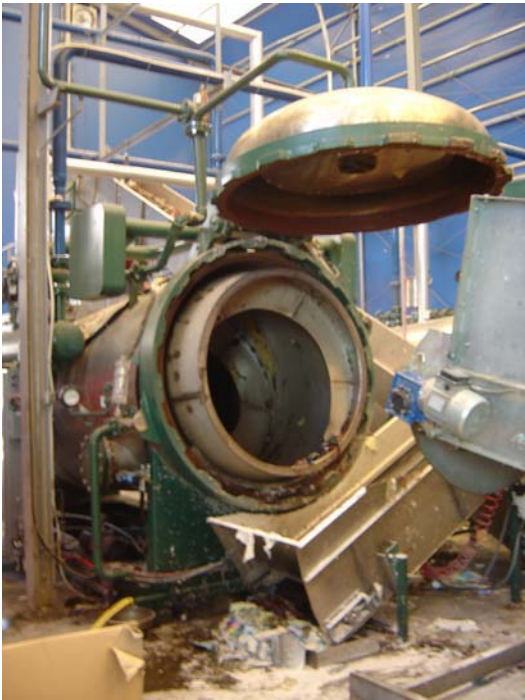
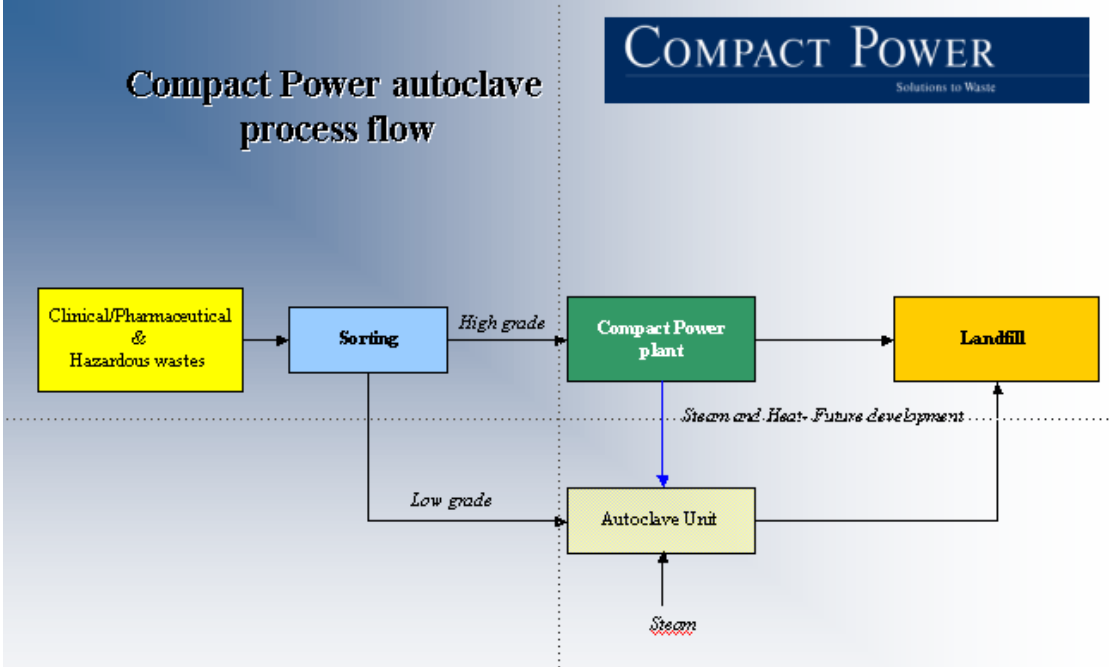

Photo DSC01826
Autoclave Unit

Compact Powers Future

The company is positioning itself to be part of an integrated waste management system in line with the European Union regulation and policy. The ultimate process and plant are shown Figure D6 and D7 below:

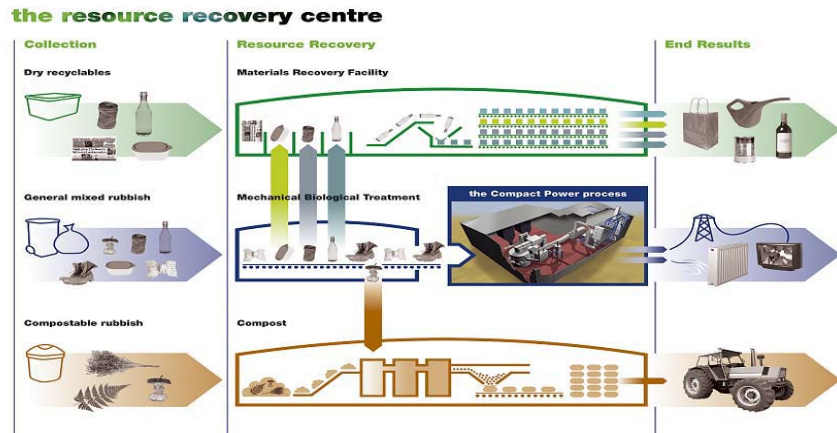

Figure D6

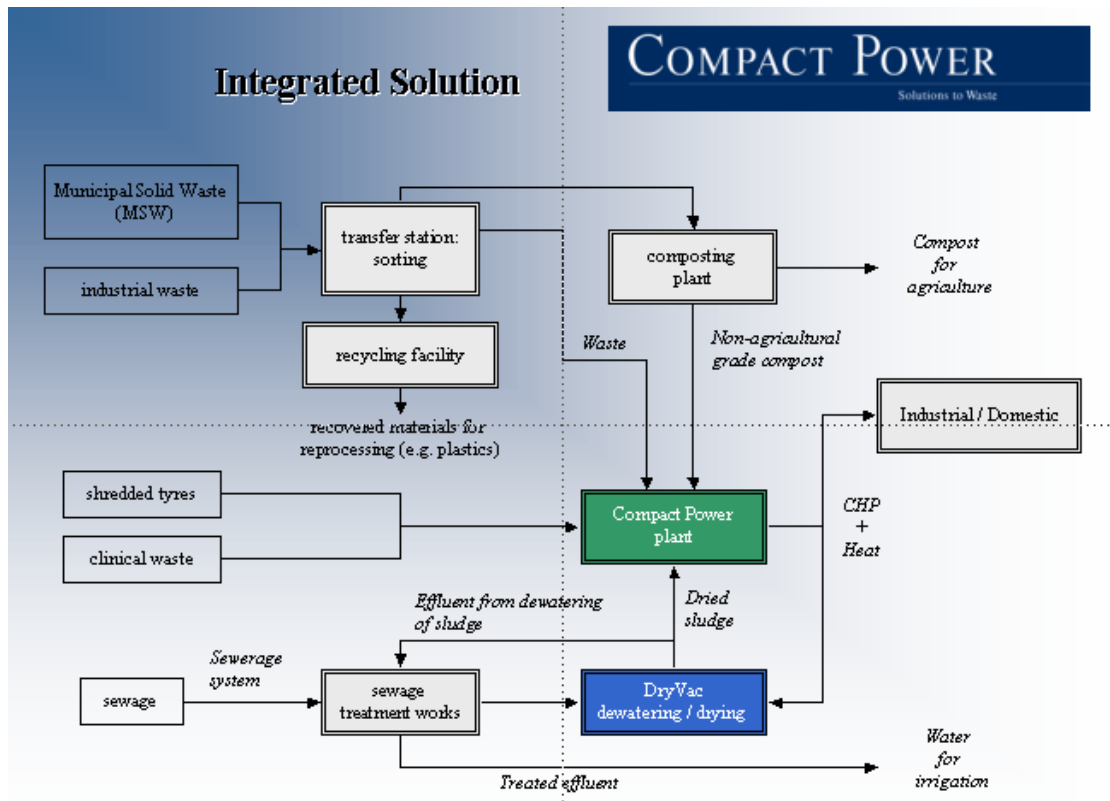

Figure D7

Discussion

While the Bristol plant was designed to accept municipal waste it is currently focussing on the higher value medical waste stream with the calorific value provided by adding tyres to the input waste stream.

Compact Power is likely to be awarded a contract from Bristol to manage all municipal waste in the next six to twelve months. The plant will be extended on the current site to manage this waste stream.

10 Issues Arising from Site Visits

During the evaluation of waste disposal facilities in Europe, it was realised that many of the issues facing Europe were very different to those being experienced within Australia currently. Population demographics, land availability are a couple of the issues that are significantly different in Europe to that of Australia to such an extent that the current facilities in use overseas are not conducive to the Australian situation.

One major factor that has precipitated the progression towards Alternate Waste Treatment (AWT) in Europe has been the European Union's (EU) strategy direction and current position for the disposal and treatment of waste. To quote from the European Environment Agency:

“The cornerstones of the EU's strategy to coping with waste are to:

- Prevent waste in the first place.
- Recycle waste.
- Turn waste into a ‘greenhouse neutral’ energy source.
- Optimise the final disposal of waste, including its transport.

Although the (EU) has a number of targets and Directives supporting these aims, the data is patchy due to a lack of consistency across the EU. What is abundantly clear, however, is that some of these targets are not being met.

To begin with, a wide range of different waste streams are increasing in volume, from consumers generating too much household waste to more wastewater treatment plants producing larger amounts of sewage sludge. What is more, waste disposal methods are not coping with the increased loads, with several countries increasing the amount of biodegradable waste sent to landfill.

Finally - and most importantly - waste generation is still linked to economic activity, meaning that, as Europe's economy grows, the waste problem will grow with it.” (Source: European Environment Agency (web site) – Waste > Indicators).

Other equally important issues play an important role in determining the viability of AWT to that of conventional landfill.

Some of the other issues that became evident during the site visits are:

- Government Support.
- Legislation Requirements.
- Funding Options.
- Community Acceptance of Alternate Waste Disposal Systems.
- Siting Requirements.

- Available Technology.
- Bi-Products.
- Emerging Trends.
- Industry Support.
- Costs (Capital, Operating & Disposal).
- Transport Costs.
- Influencing Factors.
- Occupational Health and Safety Requirements.
- Labour Requirements.
- Commodity Markets.
- Guaranteed Supply of Waste.

It was also noted that the issues listed above varied greatly between the different countries of Europe.

10.1 Government Support

The provision of AWT facilities in Europe has a high level of Government support. The various regions, for which they serve, are usually directly involved with their construction and therefore provide a level of support and surety to the project.

The level of overall support is reflected in the following extract from “Energy from Waste: A Good Practice Guide © CIWM, November 2003”.

“Many countries have in general adopted and implemented the European Community policy on waste. Thus, the key directives on incineration, landfill and packaging all form part of the legislation drivers for waste management. Other measures include the setting of targets for recycling, recovery and landfill diversion that are either aspirational or have been introduced by statutory requirements. The general emphasis for waste management is to increase waste diversion from landfill and maximise all forms of recycling and recovery. Various policy measures have been introduced or proposed, eg: tax on disposal to landfill, support for recycling markets, etc.”

The federal and State Governments of Australia need to provide support for AWT facilities if they are to succeed in Australia. Actual funding assistance for the establishment of a new type of facility would be a suitable option.

10.2 Legislation

Legislation that is currently in existence and as is proposed for the European Union written to ensure there is certainty within the industry that Energy from Waste (EfW) facilities, including incineration, digestion, biogas removal, etc., are the preferred form of treatment for waste to that of landfill.

Legislation prohibiting the depositing of waste at landfills prior to some form of treatment is also in place to ensure the future viability of the AWT industry.

10.3 Funding Options

As far as can be ascertained, all of the facilities are either privately owned or run as a consortium utilising funds from Government and the private industry. Each facility from its conception to its operation takes a number of years and involves the analysis of a number of funding options and business cases covering whole of life analysis for various treatments.

Within Australia, similar process would or should be applied. Matters such as planning approvals, environmental impact statements, etc are required for all forms of waste disposal. The processing time for the provision of a AWT plant would be a similar length of time to Europe, if not longer.

10.4 Community Acceptance of Alternate Waste Disposal (AWD) Systems

Within the European community there is an overall acceptance of waste to energy plants utilising thermal and incineration systems. This is evidenced by the fact that many of the facilities are built within residential areas with minimal buffer distance between the facility and the residential precinct.

In Switzerland, the tour group was advised that Greenpeace does not have the same issues as those being experienced in Australia. It therefore stands to reason that the development of plants in Europe does not attract the same level of opposition as it would in Australia.

Many of the facilities are architecturally designed to blend into their surroundings and remove the stigma associated with waste treatment plants. They make use of the latest technology relating to the containment of odours and the treatment of gases released during the treatment process.

There is no reason why Australia could not follow the same or similar path as Europe when our reserves of land suitable for landfills was depleted.

10.5 Siting of Facilities

Siting of waste disposal plants is dependant on compliance with appropriate controls developed to cover specifically those aspects relevant to protection of the community.

CITEC (acronym for Committee on Technologically Complex Systems) a European company, has prepared a specific guideline covering the design, production and running of high technology plants for the disposal of urban waste. Three general rules in the Guideline are in part:

- The plants for disposal and recovery of waste have to be assimilated to all the other public services (sewerage, power, roads, etc).
- The plants for the disposal and recovery of waste must be considered as an important part of the territorial planning and so they have to find a role inside territorial plans.
- The plants location, performed in regard to the Environmental Impact Assessment (EIA) rules, shall be connected with an environmental general plan so to put in relationship the different components of the territory. This process constitutes a segment of a bigger process that leads to the destination of use of the space which is useful to an organised community life.

Another influence, and an important one in respect of the Australian context, to the siting of a facility relate to transport costs. As is the case in Australia, one of the major costs in the treatment of waste is the cost to transfer the waste from its source to the facility. The population density in the regions within European countries is such that a more adequate waste stream required to operate an AWT facility efficiently can be obtained within a relatively small area.

It is an accepted fact that siting of a AWT facility is critical. However, given the overall acceptance of the various AWT facilities throughout Europe, siting does not cause any major issues. In Australia, siting does raise a number of concerns that require extensive research and reports to resolve.

10.6 Available Technology

It is clearly evident that there was a wide variation of technologies in use throughout Europe for the treatment of waste. This, in part, has come about by the EU's direction, giving confidence to the various companies involved in waste disposal to fund research and the development of the alternate plants. Australia is still in its infancy with respect to AWT. Landfill remains the preferred form of disposal.

10.7 By-Products

As part of the development of treatment processes, consideration is also given to by-products. These by-products can affect the adopted process. Whether to sort waste before or after its treatment will impact on the by-products.

By-products range from recovered steel, non-ferrous metals, plastics, paper, etc. The level of removal is dependent on the type of treatment proposed. For example:

- Production of (RDF) Refuse Derived Fuel would normally require the removal of metals only.
- Incineration can sustain the removal of metals before or after.
- Digestion and Composting requires sorting and separation prior to treatment.

By-products, such as the slag from an incinerator, were further treated by separation of ferrous and non-ferrous metals prior to the residual material being taken to an inert landfill for final disposal or used for road base.

In a number of towns, where source separating is practised within the community, remaining waste was generally deposited direct to the waste facility and incinerated without pre-treatment.

10.8 Emerging Trends

Emerging trends in Europe are clearly directed towards AWT and EFW disposal methods. The range of waste treatment facilities already in use within Europe, ranging from incineration, composting, production of RDF, etc, clearly define the emerging trend within Europe that “no untreated waste is to go to landfill” and ultimately there will be no waste deposited to landfill. Treatment and reuse of all waste is the ultimate goal for the European Union.

Within Australia, an increased emphasis on recycling has assisted in the amount of waste deposited to landfill being significantly reduced. Further assistance in variations in packaging requirements will reduce the amount even further.

10.9 Industry Support

The level of general acceptance of the various waste disposal methods in Europe, together with the Government backing for the reduction in waste going to landfill, has led to a high level of involvement from the waste industry for the development of alternate waste disposal techniques. Many companies in Europe have formed consortiums with regional government bodies to provide the best facility for the best price to meet the communities’ expectations. After overcoming the many constraints associated with AWT in Australia, there is no reason why similar consortiums would not be established.

10.10 Costs

With the development of new waste disposal techniques and the high level of technology behind the various forms of waste treatments currently available, comes a high capital cost. Many of the facilities visited cost ten of millions of Euro dollars to construct. These plants, when operational, handled in the order of 100,000 to 150,000 tonnes per year of waste. The landfills visited handled up to 1,000,000 tonnes of waste per annum, well in excess of the AWT plants.

In addition to the high capital cost came a high operating cost. Recovery of these costs was reflected in the charge per tonne for the disposal of waste. This fee was set to recover day-to-day operating expenses and impart the recouping of the capital investment. Indicative costs for the treatment of the waste at the facilities were in the order of A\$110 to A\$130 per tonne and was dependant on the type of treatment provided.

Power generation, by utilising the heat generated from an incinerator or the burning methane gas, provides a small income to offset treatment cost. The majority of the funding is from direct disposal charges.

Gate charges were in the order A\$170 to A\$260 per tonne. It was apparent that the gate fee did not reflect the true operating costs of the facility and that the plant operator relied upon additional income or subsidy to remain financially viable. The additional income was derived from product sales or government/industry subsidies.

10.11 Influencing Factors

Factors influencing the use of an AWT facility are directly impacted by the likelihood that inappropriate waste may be disposed at the facility. This is difficult for the operator to control and in a sense beyond the control of the operators.

Throughout the process, monitoring on all gases produced by the incineration is carried out to ensure compliance with EPA standards. Appropriate measures are taken to remove toxic emissions prior to any release to the atmosphere.

Notwithstanding the above, nearly all the facilities visited were diligent in ensuring that there was no radioactive material within the waste being taken to the treatment plant. All trucks entering the facilities were screened for radioactive material. No figures were given on the amount of radioactive material found however the fact that these are provided means that the overall industry has concerns about the waste being deposited at their facilities.

10.12 Occupational Health and Safety Requirements

It was generally accepted by four participants that the Occupational Health and Safety requirements at many of the facilities visited were not as stringent as those currently being experienced within Australia. At a number of plants, the storage of tools and equipment was poor.

General acceptance of hazards in the community was also evidenced by the state works were left during road and footpath works being carried out in the community. Tripping hazards, repair work left incomplete, poor signage, etc, were evident throughout a number of the cities and towns visited.

It should be noted that this was not in any way the norm across Europe, but was quite noticeable at various locations.

10.13 Labour Requirements

With the inception of these AWT facilities and new technologies in the field of computerization and automation, the number of personnel to operate the facilities is in excess of the number of staff that would be required to operate a landfill, for argument sake, handling 100,000 tonnes. The number employed did vary at the different plants but usually related to the complexity of the process.

As a comparison, an incineration plant handling in excess of 100,000 tonnes per year and operating 24 hours per day, only shutting down for maintenance purposes, would employ in the order of 30 to 35 EFT's. This compares to the Australian situation where a major landfill handling the same magnitude of waste per year and opening only on daylight hours, employs in the order of 5 staff.

10.14 Commodity Markets

With respect to composting of waste, there was no evidence that a sustainable market had been realised within Europe for the use of the compost products. Much of the treated material was either going to landfill as treated waste or to agriculture. The material used in agriculture did not accrue an income but was seen as the final proposal process for the treated waste.

It should be noted that within Switzerland, Government legislation prohibits the use of composted material as fertiliser for farmland.

10.15 Guaranteed Supply of Waste

In conjunction with the building of a facility, comes the need to ensure that supply is kept up to that facility to make it a viable proposition. By working with the regional governments, supply is guaranteed as part of the investigation and construction of the facility. In many countries separation of the waste at the source is encouraged. However, the introduction of this further separation inhibits the amount and quality of waste being delivered to a particular facility.

It is well known that plastics have a high calorific value and therefore is advantageous in the incineration process. Subsequent removal of these products from the waste at the source may in turn affect the operation of the plant.

The EU has also set waste targets that are aimed at reducing the levels of waste generated per person. These will also impact on the operations of an AWT facility. There has been some difficulty in meeting these targets as shown in the article below.

(Source: European Environment Agency – Waste generation from household and commercial activities [2001]).

Daily household and commercial activities generated around 400 kg of waste per person in 1996. This included both mixed household rubbish and separately collected waste such as paper and glass.

The EU's 2000 target for municipal waste, mentioned in the 5th Environmental Action Programme, was 300 kg per person per year. Municipal waste, however, is a broader term, including much more than household and commercial activity waste. Factor in the trend towards increased waste generation since 1996, and it becomes clear that the 300 kg limit will not be reached without significant cuts in household waste generation.

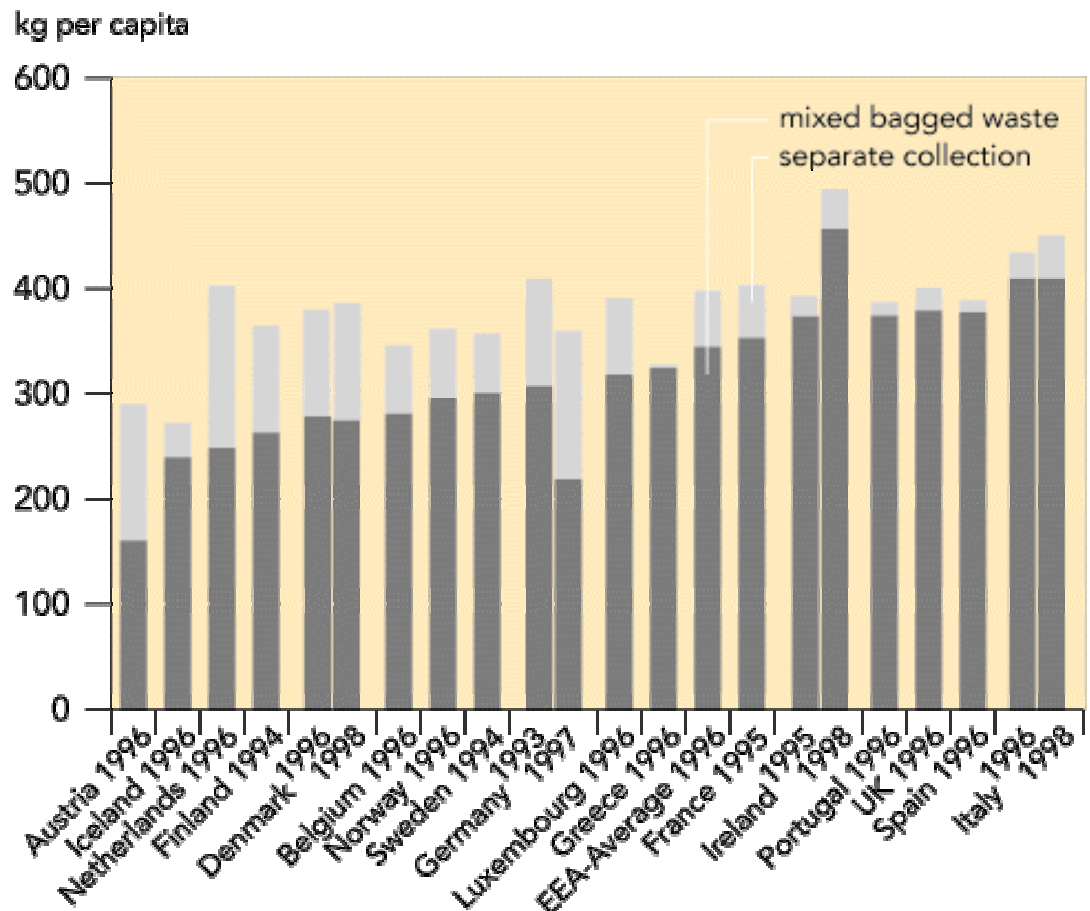
European Union Members – per Capita Waste

Given Australia's direction towards reducing waste to landfill and consequently reducing the waste generated per capita, the guarantee of supply for certain types of AWT plants may be affected.

For example, the removal and treatment of organic waste is growing industry and given current trends unlikely to run short of supply. Packaging restrictions however, may reduce the effectiveness of RDF's and as such require enhancement with an actual fuel.

In comparison, data collected by EPA Victoria shows that the daily household and commercial activities generated approximately 335kg of waste per person per annum in Victoria.

11 ISWA Congress – Rome 2004

As part of the study tour, the tour participants had the opportunity to attend the International Solid Waste Association (ISWA) 2004 World Congress held in Rome.

ISWA is an independent international, non-governmental and no-profit organisation established in 1973. It has National delegations in 24 countries around the world and individual members in 50 additional countries.

ISWA's mission is "to promote Sustainable Waste Management World Wide". It achieves its mission by carrying out studies, research and reports from its different working groups co-ordinated by the Association.

The reports and findings are used by many authoritative organisations such as the European Union and the World Bank.

Each year ISWA meets in a General Assembly followed by International Congress at which information is disseminated to its members.

At the congress held in Rome at the Palazzo Dec Congress between 17 October and 21 October 2004 a large number of technical papers were delivered by a range of international speakers on topics with relevance and significance to the delivery of waste management services.

The topics covered were broad ranging and highly technical in nature and included papers on:

- Recovery and Recycling Strategies.
- Treatment of Biowaste.
- Waste to Energy.
- Sanitary Landfill and Site Remediation.
- Waste Collection Transport/Urban Hygiene.
- Strategies for Developing Countries.
- Social and Communications Issues.
- City Strategies in Waste Management.
- Developing Countries Issues and Experiences.
- Environment Assessment LCA and Quality.
- Hazardous and Health Care Waste, Recovery.

An overview of the papers including an abstract of the paper presented at the Congress is set out in Appendix 3.

Details of all papers are available from ISWA or copies can be obtained from one of the tour participants.

Many of the topics were highly scientific in nature and theoretical in nature. Although many of the topics were of no benefit to Local Government Engineering the sessions were broken up in such a way as to allow you to attend what was most relevant to your particular profession.

The private industries would have gleaned some useful information, as would have the manufacturers of particular technologies.

The conference was also nearly entirely delivered in Italian or French thus making it difficult to concentrate and understand the speakers through the interpreters. The conference papers were however produced in English and were available on disk rather than hard copy, which would have made following the speakers a lot easier.

The displays were very minimal and didn't provide a lot of information for conference attendees. Australian and American conferences were certainly a lot better organized and the information provided a lot easier to understand and apply. Having said this visiting a European Cities will almost certainly provide challenges to English speaking attendees.

The Abstracts and the contact details are provided as part of this report which should make it a lot easier for those wishing to follow up topics of interest.

In summary the conference was only just worth it from a technical and networking point of view. Some of the awardees did attend the ISWA conference in Melbourne recently and found it extremely useful and well worth attending. We would recommend that rather than rely on one experience to judge whether a congress of the nature was useful to attend for future awardees that the following should be considered.

- Country where congress is being held (Language barriers).
- Are papers and programs relevant to Local Government?
- Quality of Technical Tour program.

The following paper summaries are extracts from the various papers presented at the conference and are provided to support our findings on the study tour. A complete overview of all papers is contained in Appendix 3.

Alternative Strategies For Energy Recovery From Municipal Waste In Incinerators And Existing Industrial Plants

Paper by: M. Grosso, S. Consonni, M. Giugliano, L. Rigamonti
Politecnico di Milano, DIIAR Environmental Section, Milano, Italy
Politecnico di Milano. Department of Energy Engineering,
Milano Italy mario.grosso@polimi.it

The paper assessed different strategies for energy recovery from Municipal Solid Waste by dedicated plants and existing industrial facilities. The former included state-of-the-art Waste-To-Energy (WTE) plants generating electricity and heat through a steam cycle, while the latter include the co-combustion of Refuse Derived Fuel in power plants and cement kilns. The paper concluded that there were different environmental standards applied to each method of disposal and the method is sometimes a smoke screen in respect to waste disposal rather than truly being energy production driven. This was the same conclusion that the study tour participants drew particularly with the visit to the cement kiln.

It was noted within the paper that there is ongoing debate at the EU level on the actual role of energy recovery within Waste Management Integrated Systems (WMIS) which is focused on the difference between combustion of waste in dedicated Waste-To-

Energy (WTE) plants and co-combustion of Refuse Derived Fuel (RDF) in existing industrial plants.

It was noted that based on recent communication from the EU, the first option must be the type of disposal, even if the energy content of waste is recovered with high efficiency, ie combining power and heat production. On the opposite side, the production of RDF for co-combustion is strongly favoured by the EU legislation as this option is considered an actual energy recovery, with fossil fuel substitution. When the current situation of energy recovery from waste is considered, direct incineration in WTE plants is still the most common option in Italy and in most of the EU countries. Moreover, the wider experience acquired in combustion optimisation, power production and flue gas control systems in recent years, state-of-the-art WTE plants allow fulfilling very interesting energetic and environmental performances.

It is noted that the EU Report “Refuse Derived Fuel, current practice and perspectives” makes a comparison between the use of RDF in brown and hard coal power plants, cement plants and MSW incineration plants. The main conclusions of the study were that the use of RDF in industrial processes has some advantages compared to incineration (more flexibility, no need to feed the plant with a constant amount of waste, opportunities for future recycling programs), it is noted that the major concerns are related to the release of heavy metals in cement and in other by-products and to the atmospheric emissions of mercury.

The study by GUA (noted in the paper) compared landfilling with different strategies of waste management, including incineration and RDF co-combustion in different industrial plants, based on a cost-benefit analysis. All recovery scenarios were shown to be more preferable to direct landfilling, both from an environmental and economic point of view. Fuel recovery via RDF was seen as well suited for sparsely populated regions, while for larger cities a combination of fuel recovery with direct incineration seemed to be a preferred option.

The paper concluded that results show that none of the three strategies is systematically preferable to the others, as the different characteristics of the processes have different impacts on each considered pollutant.

WTE plants were subject to very strict emission limits for all the pollutants, thus leading to very low emission factors at the stack. The paper contends that the electric energy produced by the plant will displace a combined cycle power plant, the environmental balance will turn out to be positive, ie the emission from the WTE will be higher than the emissions of a combined cycle producing the same amount of energy (with the exception of CO and NO_x). WTE plants are also penalized with respect to co-combustion ones when fossil CO₂ emissions are considered, because the latter the RDF displaces high carbon content solid fuels.

On the other side cement kilns are subject to higher emission limits than WTE plants, and this may lead to the consequence that the co-combustion of RDF will help to reduce such emissions, as is the case for NO_x. Atmospheric emissions of micro pollutants (especially mercury and dioxins) are a source of possible concern, as no dedicated system for its control are installed in a cement kiln.

Energy Recovery From MSW Through Production Of High Quality Solid Recovered Fuel (CDR-P)

Prepared by: M. Frigerio, C. Zanotta, L. Zucchelli Pirelli and C Ambiente SpA

In the management of Municipal Solid Wastes (MSW), after collection of recyclable components, residual fractions remain to be treated and recovered. The standard process used to treat and recover the MSW residuals (MSWR) is the temperature combustion in waste incinerators with energy recovery from the flue gases. These plants are very capital intensive, mainly due to investments for the emissions treatment section, and very often the building of a new plant is not accepted by the local community because of the perception of environmental risks.

The research contained within this paper examines the possibility to convert MSWR to a standard, regular fuel (CDR-P, to be used as co-fuel with coal) through a low environmental impact process. This could open the possibility of using existing, thermal plants (like coal fired power plants, cement kilns) to recover the energy content of MSWR.

A demonstration plant was built in West Italy (Cuneo) during second half of 2002 and became fully operational in January 2003.

In the management of MSW, after collection of recyclable components, residual fractions remain to be treated and recovered. It is argued that these fractions are in effects renewable energy resources because the heat content is appreciable and is stable, and reliable for day-by-day production related to the citizen life style. A part of the residual fraction is also renewable in a biologic sense because it comes from the biosphere cycles (wood, vegetables, paper).

The standard process used to treat and recover the MSW residuals (MSWR) is the temperature combustion in waste incinerators with energy recovery from the glue gases. These plants are very capital intensive, mainly due to investments for the emissions treatment section, and very often the building of new plant is not accepted by the local community because of the perception of environmental risks.

“As is” MSWR is a fuel of inconsistent quality, only through pre-processing, interest arises in the co-utilisation of pre-processed MSWR with coal in combustion processes which were originally designed for coal use. In some cases, these involves partial replacement of coal with waste material in existing plants, this substitution offers the potential to increase power and thermal energy generation from waste material relatively quickly with limited investment cost and at low risk.

Although there have been many developments in Europe and US on the co-firing of refuse derived fuel (RDF), the Pirelli concept discussed in the paper differed in the following aspects:

- The non-recyclable and combustible fraction of MSW are mixed with post industrial plastic and rubber residues and the mix is subjected to the minimum level of processing (shredding and drying) to “manufacture” a fuel of specified calorific value.
- Use of this product as a marketable fuel in various existing suspension fired processes, such as cement kilns and coal fired utility plants.

- The physical form of the fuel (CDR-P) is specially designed to allow suspension co-firing of this fuel with coal in the combustion chamber of the power plant/cement kiln.

The paper explores the risks involved with each process and the overall responses to the issues and the success of the plant being described.

Attendance at the ISWA Congress gave the tour participants opportunities to network with technical professionals and managers working in waste management and allow an exchange of knowledge and information on the latest technology and practices being used worldwide in the delivery of waste management systems and services.

12 Conclusions

12.1 Future of Landfill

Evidence suggests that Waste Hierarchies in both Europe and Australia place landfill as the least desirable waste disposal option.

Despite this the need for landfills into the foreseeable future will still be significant for a number of reasons:

- Community acceptance of Alternate Waste Technologies as a system for the treatment of wastes.
- The time required establishing user groups and the raising of funding for development of Alternate Waste Technology systems as a method of waste treatment.
- Availability of landfill air space.
- The available options to rehabilitate disused material extraction sites using various forms of landfill technology.
- The time required to implement or ability for industries to “take up” waste reduction initiatives, product stewardship, and product/material bans.
- The need to dispose of residual waste from various waste treatment systems and ash from incineration or other waste to energy processes.

All alternate waste treatment systems have a requirement for disposal of residues ranging from 10%-25% of input volume of material.

Policy on Siting/Development

Landfills although undesirable are a proven technology and their risks and limitations are well understood.

European as with Victorian policies and Legislation continue to increase regulation and controls on the siting and management of landfills and their potential impacts on air, water and land.

Generally, the Victorian Environment Protection Authority is pursuing a policy of reducing the number of available landfills, closure of small landfills and the upgrading of standards at operating landfills.

Post Closure Management

Much of the direct impact of landfills has been as a result of lack of management and monitoring of sites post closure. Current legislation in Europe and Victoria is ensuring that responsibility for landfills continues post operation until it is evident that no likelihood of impact exists.

Financial Assurance/Guarantees

Similar policies and legislation have also been developed which ensure that appropriate financial assurances are provided by landfill operators. These provide a third party with the ability to address any environmental impacts that may occur, carry out any rehabilitation and ensure post operation management/monitoring of a landfill.

Material Bans/Restrictions

The most significant change to landfill and reducing its impact on the environment will be that of controlling the waste/material streams which will be able to be disposed to landfill – including specific material bans or pre-treatment requirements.

These controls will affect the direct and indirect impacts of landfills on the environment in a number of ways:

- Reduction of organic waste will reduce the production of greenhouse gases, leachate production, and conserve landfill airspace.
- Pre-treatment of a stabilizing nature will reduce the production of greenhouse gasses, leachate production and reduce volume of waste resulting in conservation of landfill airspace.
- Pre-treatment of a mechanical separation nature will reduce volume of waste and conserve landfill airspace, and recover material for reuse or reprocessing.
- In Victoria consideration is being given to the pre-treatment of the wastes in the municipal stream by 2012 prior to the residual waste component being direct to landfill.

Targets of up to 65% diversion rates are being established.

Conventional versus Bioreactor Management

Bioreactor landfills are an accepted technology in Australia and have some advantages over conventional landfills where appropriately managed:

- They provide the ability to control the stabilization of landfill waste and reduce post closure management period, and improve volume efficiency.
- Gas production can be controlled for bioreactor landfills, particularly where the use of treated waste can be used a feedstock, and the gas recovered, for the operation of a cost efficient waste to energy system of waste treatment.

12.2 Future of Waste to Energy

Policy on Incineration

Incineration of waste is considered to be a "proven technology" in Europe with the latest Directives continuing to facilitate their establishment although with increasing the controls on emissions.

However, Environmental policy in Victoria does not specifically address incineration and does not facilitate the establishment of incinerators in a similar way.

Community and Environmental Groups acceptance of this technology will be difficult in the short term based on recent attempts to establish facilities in Western Australia and Tasmania. (Refer Appendix 5).

Further work needs to be undertaken in the development of clear policy guidelines, which are accepted to all stakeholders.

Use of Refuse Derived Fuels

The following options for the utilisation and conversion of RDF from MSW to energy have been used or could be used in the future:

- On-site in an integrated thermal conversion device, which could include grate or fluidised, bed combustion, gasification or pyrolysis.
- Off-site at a remote facility-employing grate or fluidised bed combustion, gasification or pyrolysis.
- Co-combustion in coal fired boilers using RDF as a supplement source of fuel.
- Co-incineration in cement kilns.
- Co-gasification with coal or biomass.

A recent study commissioned by the EU has reviewed the current practices of production and utilisation of RDF in the fifteen Member States. It has addressed the different concerns and questions regarding the environmental impacts of co-incineration of RDF compared with dedicated incineration.

The main conclusions of the study are that:

- With regard to the concern that RDF encourages removal from the material recovery/reuse cycle, it can be concluded that on the contrary, Refuse Derived Fuels (RDF) from MSW can be a strategic component of an integrated waste management system to reach the recycling and reduction targets for biodegradable materials going to landfill. Sorting of biodegradable materials from MSW typically produces a residual fraction of high calorific value, which can be converted in RDF.

- However, the potential for RDF production is double-edged as it could also be used to minimise the cost of compliance with Article 5 of the EU Directive with minimal environmental benefit and little effort made in terms of source separation if a lax interpretation of term ‘treatment’ in the new Waste Incineration Directive is applied.
- Market mechanisms may favour inclusion in RDF of fractions that could be recycled in favourable environmental and economic conditions. For example, competition between incineration and co-incineration facilities for calorific material may drive a decrease in gate fee for incineration plants which would act as a disincentive to minimisation, recycling and composting in situation where waste treatment are driven by price alone. However, waste treatment is usually determined by other incentives and regulatory instruments, which would ensure that residual waste is genuinely residual.
- This phenomenon could increase for some types of RDF (i.e. biomass waste) as a consequence of Directive 2001/77/EC on renewable sources of energy.
- Use of RDF in industrial processes offers more flexibility than incineration as it leaves the door open for future recycling programmes as this can be made modular, it does not need to be fed with a constant amount of waste and it does not require the need to invest in capital intense dedicated incineration facilities.
- As long as any kind of well managed recovery – ranging from recycling to energy recovery even reclamation of energy in a MSW incinerator – delivers environmental benefits, the lack of benefit from the landfill option clearly devalues the landfill alternative for high calorific value wastes.
- With regard to an environmental assessment of RDF utilisation, co-incineration of RDF in coal power plants and cement works shows ecological advantages when compared with incineration in a MSW incinerator primarily due to the effective substitution of fossil fuels, as long as the plants comply with the New EU Waste Incineration Directive 2000/76.
- This more positive result for co-incineration, however, depends on the energy effectiveness of the incineration plants which can be nearly the same as a power plant or cement plant when MSW incineration plants deliver most of their processed energy for district heating.
- However, mercury emissions might be problematic when RDF is co-incinerated in industrial processes and special measures should be developed (permits, amending 2000/76, and/or minimum quality standards for RDF).
- Co-incineration of ASR (Automotive Shredder Residues) causes a definitive increase of heavy metals such as lead, cadmium, copper and zinc in cement and other by-products produced from coal power plants when compared with fossil fuels of average quality. The latest End-of-Life Directive, which aims to reduce the contaminants level in vehicles, should ultimately improve quality of these materials.
- These effects are even more evident when co-incineration takes place in brown coal power station compared with hard coal power station.

- There is a need to investigate further possible environmental and health consequences linked to this increase as these materials are commonly used in the construction industry and these contaminants could potentially be re-mobilised. It was not possible to assess within this study the binding conditions, bioavailability and leaching of these contaminants in these products and by-products.
- The key parameters which if changed would influence the results of the environmental impact assessment are the level of technical standard for incineration and co-incineration plants; the quality of substituted fossil fuels and the energy efficiency of the MSW incineration plants.
- The new Waste Incineration Directive while aiming to close the gap in the requirements for emission control equipment between incineration and co-incineration has left divergence in emissions (i.e. dust, Nox and SO₂ emissions limit values) and has not entirely reassured environmentalists.
- There are technologies other than combustion, which can convert MSW into energy sources; gasification and pyrolysis. However, the major negative aspect of using these technologies for waste treatment is that they are less proven in operation than mass burn incineration and can be just as inflexible as mass burn incineration.

12.3 Collection/Transport of Wastes

Policy on Separation at Source

Europe does not have a consistent policy in relation to separation at source although the need to provide a separate collection system for biodegradable waste is proposed. The ability to handle source separation will continue to be a challenge with the limitations imposed by high density, multi-storey/unit and historic buildings.

The current Australian position of separation at source is supported by the European experience where the cost and technology associated with the attempt to mechanically separate mixed wastes has varying degrees of success despite the significant capital and operational expenditure directed to this exercise.

Multiple Bin Source Separation Systems

The 3 bin systems established in Victoria and across Australia are currently being challenged by proponents of “Dirty MRF” technologies. It is suggested that this should be resisted based on the ability to achieve end product quality and the potential to disengage the consumer from the conscious responsibility of waste avoidance, reuse, recycling and waste minimization.

Generally the source separated systems used in Australia are equal to or better than the European systems. The operating costs of the Australian systems are lower, the productivity and yield of materials is greater than similar systems seen in Europe.

12.4 OH&S Requirements

It appears from visual site inspections, in some of European countries visited that Occupational Health and Safety standards are at a lower level than those expected in Australia. Although difficult to quantify, it is likely that some additional cost would be expected to operate equivalent AWT facilities in the Australian OH&S Environment.

The development of appropriate OH&S standards and policies for the operation of mechanical waste separation prior to the introduction of alternate waste systems is seen as a prerogative prior to the new systems.

12.5 Legislation

The successes demonstrated by the European Union in adopting common waste legislation across the 15 member nations with significant variations in demographics, political and economic development should be an example for Australia.

The lack of common or coordinated vision and associated legislation on waste management across Australia is one of the significant differences and arguably a deficiency in comparison with Europe.

Such a coordinated national position would significantly assist in the managing the various challenges that face the Australian waste management industry which include low density, low waste volumes, economy of scale, developing critical mass, enabling of investment, common education and messages. Current cross border issues would also be resolved.

12.6 Need for National Coordinating Body to provide Vision, Leadership and Direction to Government and the Industry Sector on Delivery of Waste Services

It is evident that in Australia there is a need to follow the EU direction in establishing a peak Waste Management body to provide a vision and direction for the waste industry comprising of representatives from each state and territory from Government Agencies including Local Government and the private industry. The peak body could establish a national approach and database on the systems and technology required for the delivery of waste management services in a sustainable manner at best practice standards.

Another task could be to oversee the formulation of strategic policy, which would guide the industry and respective State Governments and Territories in the delivery of waste services.

The EU process of developing a directive which is then presented to all stakeholder for comment over a period of up to 2 years, then subject to acceptance adoption of the directive for implementation by the respective EU countries not only provides advice on future legislated direction but allows the industry time to 'gear up' to comply with the new directive.

Similar planning on a National base would have merit in addressing cross State boundary issues and facilitating the sharing of knowledge and expertise.

12.7 Need for National Planning/Operation Manual

Given the recent changes in waste management technologies and systems merit is seen in the development of a National Planning/Operation Manual documenting practices and systems used in the various States and Territories.

12.8 New Technologies in Europe

It is important to note that whilst waste management systems in Europe may differ to those in Australia due to historical, geographic and demographic reasons, there were no technologies being widely used which are not currently in place or have been trialled to some extent in Australia. Although incineration is not used in Australia the systems, concepts and its various forms are fairly well understood.

It is refreshing to identify that the Australian Waste Industry is not lagging behind through lack of technical knowledge or expertise or appropriate policies.

The recent appointments of Australian Waste Industry representatives on International Waste organisations such as ISWA and its interest groups is a significant achievement and will ensure that Australian Waste Management keeps pace with the industry internationally.

The ability for Local Government to be involved in such networks may be a valuable initiative and should be pursued.

12.9 Development of Expertise and Knowledge of Waste Industry Systems in the Local Government Sector

Evidence attained from this Study Tour highlighted that each member of the tour group had differing waste management experience, views and interests. Whilst all were interested in learning and all visited the same sites it was evident that the individual's background and interests influenced the findings and lessons learnt at each facility visited.

Attendance on study tours and international conferences such as the one undertaken by the group are generally out of reach for Local Government Engineers and hence are more likely to be attended only by individuals from the private sector of the industry. This limits the ability for Local Government Engineer to develop knowledge of the waste industry and thus engage in any debate on the subject in an authoritative manner.

Local Government and the ratepayers it represents will continue to be required to meet the growing costs of waste management and therefore it is essential that the Local Government Engineer is able to be seriously involved in the decision making processes that will impact upon them.

The proactive development of Local Government Waste Management knowledge and skills of the Local Government Engineer must be facilitated.

12.10 Questions Arising

Arising from the Study Tour are a number of questions which need to be answered in addressing AWT in the Australian environment.

They are:

- Is pre-treatment of wastes prior to landfill viable, can the costs be justified when an assessment of the benefits is undertaken?
- Can we develop viable and sustainable markets and uses for Refuse derived fuels, increased recovery paper cardboard, packaging and recyclable materials, organic and compost products which will give a return to the community?
- Should these markets be developed prior to a determination being made on the collection and treatment of the waste or material stream?
- Can we develop a pricing policy acceptable to the Community, which will allow for the raising of gate fees to a rate in the order of A\$100 per tonne which will allow for the viable operation of AWT facilities?
- Should we continue with kerbside source separation in preference to treatment at the AWT facility of mixed unsorted waste?
- Does the community accept the associated cost and need to collect, treat, recover and dispose of wastes in a manner, which reduces adverse impacts on the environment?
- If community values support the need do we actively pursue a system, which uses AWT principles?
- Is landfill still acceptable? In what form?
- What is the role of Local Government Engineer in the setting of Waste Policy?
- How do we stimulate stakeholder involvement in the development implementation of new systems?
- How do deal with potential conflict of waste minimisation and need for fixed waste feedstock to maintain a viable AWT facility?

In considering the introduction of an AWT facility:

- emerging trends in waste management need to be monitored and analysed to determine benefits;
- it is better for Local Government not to be the innovator of processes but be the facilitator and let the market place develop the process, innovation which can be better handled by the expert; and
- community exposure to risk be minimised as mistakes can be costly.

- Further it is important that the quality and reliability of the waste treatment systems be maintained to ensure that the sale of value added/recycled materials is accepted by the Community. Dealing with established and reputable organisations and marketeers is essential if the integrity of the markets and resultant Community support is to be maintained.
- That the source kerbside separation of wastes be supported. Use of source separation will contribute to the production of a quality product range at a low technology cost and thus avoid the high costs and risks associated with high technology.
- That the operator of AWT facilities takes over ownership and responsibility for the deposited waste materials including treatment, sale, reuse or disposal of residual materials.
- The quality and composition of the treated product derived from the AWT facility is maintained at a high level to ensure the development of viable and sustainable markets for the reuse of the value added products at the highest and best price.

13 Recommendations

Drawing on the experience and learning's of the Study Tour it is considered that the following recommendations be pursued:

1. Industry Knowledge

As an industry, local government keep abreast of the waste management technologies, receival and processing systems and market development with a focus on policies and strategies to minimise the waste handled.

It is recommended that:

- 1.1 A memorandum of understanding (MOU) be developed within the next 12 months between the IPWEA and the WMAA for the establishment of a Local Government Special Interest Group to allow sharing of expertise, acquisition and dissemination of knowledge of waste management technologies systems and practices between the sector and private industry.
- 1.2 The Municipal Engineering Foundation establish within the next 12 months an individual scholarship or award for two Local Government Engineers as members of IPWEA to undertake a tour every second year to maintain the knowledge in the sector and provide the opportunity to attain information on the continuous improvement in waste management systems and procedures.
- 1.3 The IPWEA, within the next 12 months in conjunction with a nominated tertiary institution, seek a Federal Government grant or subsidy for the establishment of a technical library information resource, user guides and or manual on waste management systems and practices relevant to the delivery of waste management services in Australia.
- 1.4 The IPWEA in conjunction with the private industry sector over the next 3 years develop a training module and support the training of Local Government Engineers in the development of knowledge of best practice in the delivery of waste management services.
- 1.5 IPWEA within the next 12 months make representation to ISWA to have Local Government representative appointed to a ISWA Special Interest Group established to consider matters relevant to the continuous improvement of waste management delivery systems.

2. Introduction of AWT Technologies

Prior to the establishment and development of a AWT consideration needs to be given to policy, environmental impacts, responsibilities for the operation and need for a facility.

It is recommended that:

- 2.1 IPWEA immediately make an application to the Federal Government for the establishment and funding of Research and Development Group to assess the opportunities and merits for the introduction of AWT technology into the Australian environment.
- 2.2 IPWEA in conjunction with the WMAA within the next twelve months facilitate the development of a peak waste industry advisory group empowered to:
 - Develop consistent waste management policy, which may be applied across Australian States and Territories.
 - Develop Key Performance Indicators to monitor outcomes arising from the policy development.
 - Develop guidelines on the siting operation and management of AWT facilities in Australia.
 - Develop guidelines on the use and management of carbon credits and other environmental benefit trading systems, which could subsidise the operation and management of AWT systems.
 - Seek support and understanding of the requirements of all stakeholders associated with the introduction of AWT technologies.
 - Facilitate Research and Development to achieve continuous improvement in waste management technologies.
 - Facilitate the preparation and dissemination of knowledge arising from directives developed to manage the delivery of waste management services.
 - Facilitate the use of Public Private partnership for the development of AWT facilities.
- 2.3 IPWEA within the next two years facilitate the undertaking of a study into the feasibility opportunities and funding requirements for the introduction of AWT technology in the rural regions of Victoria given the restraints of distance, logistics siting, transport costs and environmental issues.

- 2.4 IPWEA within the next two years facilitate the development of a Local Government fiscal and pricing policy model for the seamless introduction of new technologies having regard to current landfill rates/levies and need to fund disposal/treatment charges associated with the introduction of AWT systems.
- 2.5 IPWEA facilitate within the next two years the preparation of a report on the feasibility of the manufacture and use of RDF for use in co-generation of electricity and heating purposes within Australia.
- 2.6 IPWEA within the next two years facilitate a review and study of the markets available to dispose or reuse 'value added' products derived from the use of AWT systems.
- 2.7 IPWEA be requested to establish within the next 12 months a National Committee of Local Government Engineers with a term of two years to facilitate the development of process and practices to continue development and use of AWT waste management systems.

3. Landfill Technology

Landfill technology supported by recovery of recyclables is the most common form of treatment of wastes in Australia today and is likely to be used varying levels of operation for the immediate term and longer in support of AWT systems.

The need for continued assessment and investigation of the benefits of emerging landfill technologies versus the relevant AWT options needs to be addressed.

It is recommended that:

- 3.1 IPWEA in conjunction with the Victorian EPA and LG Pro Special Interest Group undertake within the next 12 months, the preparation of a report on the number, scale and operational details of landfill sites in Victoria.
- 3.2 Based on the findings of the landfill existing conditions report IPWEA and the LG Pro Special Interest Group undertake an assessment within the next two years of the emerging trends and the impacts of those trends and State Government policies on the future use of landfill technology in Victoria benchmarked against European landfill practices policies and directives.

14 Acknowledgements

The Study Tour team thank and gratefully acknowledge the support and assistance given from the following individuals and organisations:

- The Municipal Engineering Foundation Victoria for making the awards available, commitment to the development of Local Government Engineering industry and their support in the organisation of the tour and subsequent reporting on the tour findings.
- The Waste Management Association of Australia for arranging the tour itinerary, conduct of the tour and subsequent provision of information to tour participants.
- The members of the WMAA 2004 Europe Tour for their support, understanding and assistance during the tour. Details of the tour participants are listed in Appendix 2.
- The study tour team acknowledge and thank their respective Council's for the support and assistance given to allow each participant to undertake the study tour:
 - Mr David Beard City of Greater Bendigo
 - Mr Dimitri Scordalides Benalla Rural City Council
 - Mr Greg Scott Mitchell Shire Council
 - Mr John Stamp Manningham City Council
- The study tour team acknowledge and thank the various industry groups and organisations who made time and staff available to brief the team on the aspect of the facilities visited.

15 Useful Resource Documents

Burnley S.J., Coleman T and Grownow J.R. 1999. "The impact of the Landfill Directive on Municipal waste Management in the UK" *Proc Sardinai 99 ,Seventh International Waste management and landfill Symposium, Italy*

Cooper, N 2002. "Compact Power puts pyrolysis at the Heart of Sustainable Developments Optimising Value Recovery." *Proc Enviro2002 Conf March 2002*

Environment Protection authority 1991 *State Environment protection Authority (Siting and Management of Landfills receiving Municipal Waste)* Victorian Government Gazette No S40

Environment Protection authority 2001. *Best Practice Environmental Management Siting, Design, Operations and Rehabilitation of Landfills*. Publication 788.

Standards Australia 1999. *Australian Standard composts, soil conditioners and mulches*. AS 4454-1999

URS *Evaluations of Waste Management options for Bendigo August 2002*

SEDA *Waste to Energy Seminar 27th February 2003 papers and notes*

Websites

<http://kubota.co.jp/english/division/envi.html> (incineration)

<http://juniper.co.uk> (Analysis Company on waste industry)

<http://ecosolutions.com/default.htm> (manufacturers of equipment)

<http://www.compactpower.co.uk> (Pyrolysis, Gasification Company)

http://erropa.eu.int/eur-lex/en/lif/ind/en_analytical_15.html (EU Legislation)

<http://www.solarpaces.org/PYROLISIS.HTM> (Pyrolysis)

<http://www.wasteresearch.co.uk/ade/efw/gassification.htm> (Pyrolysis and Gasification)

<http://europa.eu.int/comm/environment/wasteinc> (Incineration EU directive)

<http://www.greenpeace.org/international/campaigns/toxics/incineration> (Greenpeace on Incineration)

http://nett21.gec.jp/CTT_DATA/WASTE/WASTE_3/html/Waste-108.html (grate incineration)

http://www.boschrexroth.com/corporate/en/about_us/redirect_d_c_mag/d_c_mag_01_05/technology/waste/index.jsp (grate incineration)

http://nett21.gec.jp/CTT_DATA/WASTE/WASTE_3/html/Waste-057.html (fluidized bed incineration)

http://www.jfe-steel.co.jp/archives/en/nkk_giho/85/pdf/85_07.pdf (Improvements and Recent Technology for Fluidized Bed Waste Incinerators)

APPENDIX 1

DIFFERENCES BETWEEN EUROPE AND AUSTRALIAN WASTE ENVIRONMENTS

Characteristics	Europe	Australia	Comment
Population	High Density and Numbers	Low Density and Numbers	Population numbers and densities allow development of facilities within reasonable transport distances in Europe.
Land Availability	Limited Opportunities	Many Options	Available land in Europe is limited and opportunities to develop waste facilities is restricted. To date Australia has had adequate land for landfills, however with changing community values the options may reduce in the future.
Climate	Colder	Warm	Options to obtain/achieve additional revenue from reuse of energy for heating and industry is limited in Australia. Need exists in Europe.
Soils	Generally Good	Poorer Quality	Options to use compost in Australia to enrich soils is seen as an advantage due to poor soil profile.
Economics of Scale	High	Low	A need exists in Australia to address the treatment of wastes on a larger scale to achieve economics and a reduction in unit rate costs. The scale and number of Waste Management Groups in Victoria is to be reviewed to achieve this aim.
Economy	Higher Industrial Component	Lower Level of Industry	Australia has a lesser industrial waste component than Europe which needs to be addressed in formulation of a waste treatment plan.
Government Regulation	High	Low	EU policy developed by industry and legislation enacted by Government in each EU country which applies strict controls on the handling treatment and disposal of wastes. The need for similar policy and regulations in Australia needs review.

Government Regulation (cont..)			EU requires all wastes to be pretreated prior to landfill. Limits apply to use of compost materials in Europe. EU requires a reduction of bio-degradable waste to landfill to 35% of 1995 levels by 2016. Germany in particular has developed policy to reflect Green Party programmes.
Collection Practices	Good	Very Good	Observations indicated that collection practices in Australia were equal, if not, better than the EU systems. In particular the Australian 3 bin based system provides opportunities for a cleaner and better product at source and subsequently at processing facility. OH&S issues are more adequately addressed in the Australian workplaces than those work places visited in Europe.
Organic Source Separation	Well Established	Established and Practice Improving	<ul style="list-style-type: none"> • The Australian 3 bin system allows collection at source. • Community education on the system and its benefits requires review and the results of the review may result in a restructure of services to ensure greater efficiencies are attained.
Waste to Energy	Accepted	Yet to be Accepted	Need exists to develop strategies with Environmental Groups on AWT and options for future development. It was stated on the tour that Greenpeace supported the use of incineration in Switzerland as an alternative to landfill.
Waste Disposal Fees	Up to A\$250 Per Tonne	A\$30-80 Per Tonne	Indications are that the Melbourne landfill gate will rise to approximately \$50 inclusive of State levy in the next 2 years and that the landfill charge may rise further in coming years so that the gate charges on entry to a AWT facility and landfill site will be similar at approximately A\$95-100 within 10 years.

APPENDIX 2**WMAA – 2004 EUROPEAN TOUR
TOUR PARTICIPANTS**

Graham Badman	Brentwood Recycling Systems, NSW
David Beard	City of Greater Bendigo, VIC
Colin Clissold	Burwood Council, NSW
Ian Dencker	Burwood Council, NSW
Veronica Dullens	WMAA, NSW
Haydee Forster	JJ Richards, QLD
Frank Gigliotti	Wollongong City Council, NSW
Andrew Kosciuszko	SITA Environmental Solutions, NSW
Geoff Green	Camden Council, NSW
Sue Morris	Camden Council, NSW
Cheryl Murdoch	Baxter Group Ltd., VIC
Peter Murray	Collex Pty. Ltd., NSW
Andrew Quinn	A Prince Consulting, NSW
Joe Scimone	Woollongong City Council, NSW
Dimitri Scordalides	Benalla Rural City Council, VIC
Greg Scott	Mitchell Shire Council, VIC
John Stamp	Manningham City Council, VIC
Gordon Warren	SITA Environmental Solutions, WA
Mike Williamson	Collex Pty. Ltd., NSW

APPENDIX 3

CONFERENCE ABSTRACTS

**SESSION: RECOVERY &
RECYCLING
STRATEGIES**

A FULL-SCALE COMPARISON BETWEEN A FOOD WASTE DISPOSER SYSTEM AND A VACUUM SYSTEM FOR COLLECTION OF SOLID ORGANIC WASTE

PVC RECOVERY OPTIONS, ECOLOGICAL AND ECONOMICAL SYSTEM ANALYSIS

A PROCESS OF ARTIFICIAL LIGHTWEIGHT AGGREGATES PRODUCTION FROM ACID BOTTOM ASH WASTE OF THE LIGNITE POWER GENERATION

POST-CONSUMER POLYETHYLENEPOLY (ETHYLENE TEREPHTHALATE) COMPATIBILIZED BLENDS

AN EVALUATION OF RECYCLING SERVICES USING SPATIAL ATTRIBUTES TO SUPPORT THE DEVELOPMENT OF RECYCLING STRATEGIES

INNOVATIVE PROCESS CONVERTS PVC WASTE INTO RAW MATERIALS

FROM WASTE MANAGEMENT TO RESOURCES MANAGEMENT: MATERIAL FLOW ANALYSIS - A TOOL TO IMPROVE WASTE MANAGEMENT DECISIONS

WASTE GENERATION AND MANAGEMENT IN ITALY

THE REVAMPING OF THE COMBUSTION PLANT OF AAMPS IN LIVORNO FOR RDF (REFUSE DERIVED FUEL)

FOR A BETTER PLASTIC RECYCLING: A PARTNERSHIP WITH ACCR

ACTIVATION OF A SEPARATE WASTE COLLECTION SERVICE IN SMALL RURAL CENTRES. RESULTS AND FUTURE PROSPECTS SUSTAINABLE WASTE MANAGEMENT BY AN INTEGRATED SOLID WASTE TREATMENT PLAN IN FRIESLAND, THE NETHERLANDS CHARACTERISTICS OF ECO-FRIENDLY POTS MADE FROM *SHOCHU* DISTILLATION LEES

END-OF-LIFE VEHICLE RECYCLING: THE VOLKSWAGEN-SICON-PROCESS FOR THE RECYCLING OF SHREDDER RESIDUES

PRE-TREATMENT – TOWARDS INTEGRATED WASTE MANAGEMENT

VINYL 2010: THE VOLUNTARY COMMITMENT APPROACH OF THE EUROPEAN PVC INDUSTRY TO THE CHALLENGE OF SUSTAINABLE DEVELOPMENT

HEAVY METALS REMOVAL FROM AUTOMOBILE SHREDDER RESIDUES (ASR)

TECNOLOGY AND EXPERIENCE IN THE TREATMENT OF INERT MATERIALS AFTER THE EARTHQUAKES

WHY ARE NOVEL TECHNOLOGIES NOT MAKING AN IMPACT ON THE PROCESSING OF POST-CONSUMER WASTES?

BEYOND RECYCLING TO SUSTAINABLE PRODUCTION & CONSUMPTION

SESSION: TREATMENT OF BIOWASTE

POLICY EVALUATION FOR SOLID WASTE MANAGEMENT BY WLCA IN JAPAN

THE AF-BNR-SCP PROCESS: FOCUSING ON THE ANAEROBIC CODIGESTION STEP OF SEWAGE SLUDGE AND OFMSW IN THE FULL SCALE EXPERIENCE OF AN OFMSW/WASTEWATER INTEGRATE TREATMENT

SIGNIFICANCE OF SOURCE SEPARATION AND COMPOSTING OF WASTES OF ISTANBUL: FROM THEORY TO PRACTICE
USE OF STABILISED BIOWASTE IN CLAY QUARRY ESTORATION: MONITORING OF ENVIRONMENTAL EFFECTS

BIOLOGICAL HYDROGEN PRODUCTION BY THE ANAEROBIC FERMENTATION OF SOLID WASTES

MONITORING OF COMPOSTING PROCESS BY THE DETERMINATION OF DYNAMIC RESPIRATION INDEX (DRI) AND SOME CHEMICAL-PHYSICAL PARAMETERS AT THE VESTA PLANT OF VENICE
INNOVATIVE TECHNOLOGIES FOR BIOLOGICAL TREATMENT OF BIOWASTE

FACTORS AFFECTING THE TREATMENT OF MUNICIPAL SOLID WASTES (MSWS) IN SIMULATED ANAEROBIC RECYCLED REACTORS: SHREDDING AND COMPACTION

REVAMPING OF CARPI COMPOSTING PLANT

HOUSEHOLDER ATTITUDES TO WASTE MINIMISATION THROUGH HOME DIGESTION OF BIODEGRADABLE WASTE

BENCHMARKING OF QUANTIFICATION AND SEPARATION TECHNIQUES FOR HEAVY METALS IN LEACHATE FROM LAB-SCALE LANDFILL

SUITABILITY OF THE SOUR TEST TO ASSESS STABILITY IN COMPOSTS PREPARED WITH OLIVE OIL INDUSTRY WASTES
PCDD/F EMISSIONS FROM BIO-MECHANICAL MSW TREATMENT FACILITIES

STATE OF THE ART OF BIODEGRABABLE WASTE MANAGEMENT IN ITALY

BIOLOGICAL STABILITY AND ODOURS PRODUCTION DURING BIOLOGICAL TREATMENT OF MUNICIPAL SOLID WASTE

TECHNICAL AND ECONOMIC ASSESSMENT OF QUALITY COMPOST PRODUCTION FROM AGROINDUSTRIAL WASTE

CRITERIA FOR ASSESSING LIQUID WASTE TREATABILITY IN MUNICIPAL WASTEWATER TREATMENT PLANTS

SYSTEMS APPROACH TO PROMOTION OF SEWERAGE SLUDGE RECYCLING IN JAPAN

COMPARISON OF DIFFERENT HYPOTHESES FOR THE MANAGEMENT OF ALGAE COLLECTED ON SEA SHORE

SEWAGE SLUDGE COMPOSTING IN MURCIA (SPAIN) BY BIOMAX-G TECHNIQUE

UPGRADING OF THE PIETRAMELINA COMPOSTING PLANT FOR THE PRODUCTION OF HIGH QUALITY COMPOST

ANAEROBIC DIGESTION POTENTIAL OF URBAN ORGANIC WASTE: A CASE STUDY IN MALMÖ

THE BIOMASS COMPOSTING PLANT FOR ORGANIC WASTE FROM SEPARATE COLLECTION AT MACCARESE (ROME): AN EXAMPLE OF THE OPTIMISATION OF TERRITORIAL INTEGRATION

USE OF STABILISED BIOWASTE IN CLAY QUARRY RESTORATION: MONITORING OF ENVIRONMENTAL EFFECTS

THE INFLUENCE OF THE QUALITY OF THE BIOWASTE ON THE QUALITY OF COMPOST COMING FROM TUSCANY PLANTS

SESSION: WASTE TO ENERGY

AVOIDING HIGH TEMPERATURE BOILER CORROSION BY MEANS OF A BOILER PRISM

SER: SECONDARY ENERGY RESERVOIRS

REMOVAL OF DIOXIN FROM FLUE GASES BY THE ADIOX TECHNOLOGY

SIMULATION MODEL OF A PILOT SCALE MSW INCINERATOR

FATE OF HEAVY METALS IN
SEWAGE SLUDGE INCINERATION
BY A FLUIDISED BED AND A
ROTARY KILN FURNACE

USE OF REFUSE DERIVED FUELS
AND THE IMPLEMENTATION OF
MISSIONS TRADING -POTENTIALS
AND ECONOMIC BENEFIT-

NEW ADVANCED TECHNIQUES
FOR THE OPERATION OF THE
FLUE GAS CLEANING LINES OF
WASTE INCINERATORS

THE CASE OF ALESSANDRIA:
PRODUCTION PLANT FOR RDF
(REFUSE DERIVED FUEL)

THERMAL TREATMENT OF
WASTE FUELS IN CFB BOILERS -
LATEST DESIGN AND
EXPERIENCE

AN ADVANCED CONTROL
METHODOLOGY: HE EXPERIENCE
AT AN ITALIAN MSWI PLANT

ELECTRIC POWER PLANT
FUELLED WITH FUEL (SRF)
GASIFICATION PLANT OF
MALAGROTTA
OPTIMISATION OF RESOURCES
AND COSTS FOR THE EMISSION
CONTROL OF AN EXISTING
MUNICIPAL WASTE
INCINERATOR

PROCEDURE FOR HEALTH RISK
ASSESSMENT FOR AIR EMISSIONS FROM
MSW INCINERATION PLANT

ANALYSIS OF THE EMISSIONS OF A
WASTE POWER PLANT AND EFFECTS ON
THE AIR POLLUTION IN THE
SURROUNDING AREA

RELEASE OF TOXIC TRACE
CONTAMINANTS FROM MSW
INCINERATION

ALTERNATIVE STRATEGIES FOR ENERGY
RECOVERY FROM MUNICIPAL WASTE IN
INCINERATORS AND EXISTING
INDUSTRIAL PLANTS

CO-INCINERATION OF MUNICIPAL
SLUDGE IN AN MSW FURNACE USING
PYROMIX PROCESS

POWER GENERATION FROM BIOGAS: THE
EXPERIENCE ACQUIRED BY MARCOPOLO
GROUP IN ITALY

CATALYTIC DECOMPOSITION OF PCDD/FS
ON V2O5-WO3/AL2O3-TIO2 CATALYST

THE LOW TEMPERATURE SHELL DENOX
SYSTEM FOR REMOVAL OF NOX AND
DIOXINS FROM WASTE INCINERATION
FLUE GAS

HOW TO DETERMINE THE LOWER CALORIFIC POWER WHEN OPERATING A MUNICIPAL SOLID WASTE (MSW) INCINERATOR PLANT IN VENICE: COMPARING METHODS.

TECHNICAL AND ENVIRONMENTAL OPTIMIZATION OF WASTE-TO-ENERGY PLANTS VIA PAN-EUROPEAN COLLABORATION

DEVELOPMENT OF THE ADVANCED WASTE INCINERATOR –MASS-BURN RENAISSANCE

ENVIRONMENT PROTECTION AND ENERGY EFFICIENCY IN WASTE TO ENERGY: THE BRESCIA EXPERIENCE

ENERGY RECOVERY FROM MSW THROUGH PRODUCTION OF HIGH QUALITY SOLID RECOVERED FUEL (CDR-P)

SAMPLING OF SOLID RECOVERED FUELS (SRF) FOR QUALITY ASSURANCE IN COINCINERATION - LESSONS LEARNED FROM THE APPLICATION OF CEN TC 292 DRAFTS

DESIGN OPTIMISATION OF SEWAGE SLUDGE DRYING AND INCINERATION

SESSION: SANITARY LANDFILL AND SITE REMEDIATION

GASEOUS EMISSIONS FROM LONG-TERM EXPERIMENTS IN DEPENDENCE ON MECHANICAL-BIOLOGICAL PRE-TREATMENT

SIMULATION AND ANALYSIS OF LANDFILL GAS FUELLED MICROCOGENERATION SYSTEMS THE USE OF VOLCANIC SOIL AS A SANITARY LANDFILL LINER AND ITS CAPACITY TO RETAIN SOME SPECIFIC HEAVY METALS

UTILIZATION FOR ENERGY PURPOSES OF A BIOGAS PLANT IN MEDOLLA LANDFILL

TECHNICAL-ECONOMICAL ASPECT ABOUT BIOGAS PRODUCTION OF MARIANA MANTOVANA LANDFILL (ITALY)

FINANCIAL PROVISIONING FOR LANDFILLS: AN INTERNATIONAL OVERVIEW

RENATURALIZATION OF A CONTROLLED LANDFILL USING INERT EXCAVATION SOIL AND MUNICIPAL WASTE COMPOST

RECLAMATION OF A POLLUTED SITE IN SENSITIVE AREAS

PERFORMANCE BASED SANITARY LANDFILL DESIGN USING GEOGRAPHIC INFORMATION SYSTEMS INTERFACED WITH SYSTEM SIMULATION MODELS

VALUATION OF TECHNICAL STRATEGIES FOR LANDFILL ODOUR IMPACT REDUCTION USING DYNAMIC OLFACTOMETRY

CHALLENGES OF DESIGNING A VERTICAL LANDFILL EXPANSION OVER EXTREMELY COMPRESSIBLE SOILS

THERMAL RECOVERY FROM LANDFILL BIOGAS AFTER ENERGY EXPLOITING

GAS COLLECTION EFFICIENCY IN A MUNICIPAL SOLID WASTE LANDFILL: A CASE STUDY
ROLE OF COUPLING NUMERICAL SIMULATION AND RESISTIVITY METHOD IN THE INTEGRATED MANAGEMENT SYSTEM FOR CONTAMINATED SITE REMEDIATION

USING HONEY BEES AS MONITORS OF AROMATIC HYDROCARBON POLLUTANTS IN RIO RIAZZONE WASTE-LANDFILL (REGGIO EMILIA, ITALY)

EX SITU SOLID-PHASE BIOREMEDIATION WITH COMPOST ADDITION FROM MSW: PRELIMINARY PILOT SCALE EXPERIMENTAL RESULTS ON DIESEL-CONTAMINATED SOILS

TREATMENT OF LEAD AND CADMIUM CONTAMINATED SOILS: A COMPARATIVE STUDY ABOUT SOLIDIFICATION/ STABILISATION, CHEMICAL EXTRACTION AND PHYTOEXTRACTION PROCESSES

PCB-CONTAMINATED SOILS: COMPARISON BETWEEN DIFFERENT OXIDANTS

A NOVEL APPROACH FOR THE REDEVELOPMENT OF OLD LANDFILL SITES

WETLAND TREATMENT OF LEACHATE WITH DISCHARGE TO A PHYTO-CAP TO CREATE A SELF-SUSTAINING LANDFILL: INTERIM RESULTS FROM A PILOT STUDY PROGRAM

THE "MASTER PLAN" FOR THE REMEDIATION OF THE PORTO MARGHERA (ITALY) INDUSTRIAL AREA: PREMISES AND MAIN ACTIONS

ACCUMULATION CHAMBER AS CONTROL SYSTEM FOR LONG-TERM GAS EMISSION IMPACT OF MSW LANDFILLING: PRELIMINARY EXPERIMENTAL RESULTS AND ELABORATIONS ON ITALIAN PROVINCIAL SCALE

METHODOLOGY FOR ESTIMATING TYPES AND QUANTITY OF LANDFILLED SOLID WASTE: THE CASE OF MYTILENE MUNICIPALITY (GREECE)

BENCHMARKING OF
QUANTIFICATION AND
SEPARATION TECHNIQUES FOR
HEAVY METALS IN LEACHATE
FROM LAB-SCALE LANDFILL

**SESSION: WASTE
COLLECTION
TRANSPORT/URBAN
HYGIENE**

A MODERN CONCEPT FOR WASTE
COLLECTION IN BIG CITIES

IMPLEMENTING WASTE TARIFF
IN THE MANTOVA PROVINCE:
WASTE PRODUCTION RATES
ASSESSMENT FROM HOUSEHOLD
AND BUSINESS ACTIVITIES

APPROACH FOR CALCULATING
THE AMOUNT AND THE
COMPOSITION OF BIO-WASTE
POTENTIAL AND COLLECTED
BIO-WASTE MATERIAL

PLANNING, DATA MONITORING,
RESULTS OBTAINED FOR THE
SEPARATE WASTE COLLECTION
PROJECT CARRIED OUT FOR
PERUGIA CITY COUNCIL.
COMPARISON WITH OTHER
LOCAL AUTHORITIES

AN INTEGRATED APPROACH FOR
MANAGING MSW IN A BETTER
ECONOMIC AND MORE
ENVIRONMENTALLY
SUSTAINABLE WAY

ORGANIZATION OF THE VEHICLE
MAINTENANCE SERVICE IN A WASTE
MANAGEMENT COMPANY OF A BIG CITY

PROBLEMS RELATING TO THE CARRYING
OUT OF URBAN CLEANSING SERVICES IN
AN EMERGENCY SITUATION IN THE
CAMPANIA REGION
DEVELOPMENTS IN THE INTERMODAL
TRANSPORT OF WASTES AND
RECYCLABLES IN THE UK

RECYCLED AGGREGATES FROM CIVIL
DEMOLITION

A COMPUTERISED SYSTEM APPLIED TO A
SOLID WASTE MANAGEMENT SYSTEM

NECESSARY PHYSICAL STRUCTURES FOR
THE CARRYING OUT OF THE SERVICE OF
URBAN WASTE MANAGEMENT IN THE
CITY OF ROME

WASTE COLLECTION, TRANSPORT AND
TREATMENT COSTS – A SPREADSHEET
APPROACH

UNIQUE ELECTRIC-POWERED REFUSE
REAR LOADER DEVELOPED IN SWEDEN

OPTIMISATION OF THE URBAN SOLID
WASTE COLLECTION AND TRANSPORT
SYSTEM IN THE CITY OF PERUGIA

MIDWASTE, AN ASSOCIATION OF PUBLIC
ENTERPRISES

SESSION: STRATEGIES FOR DEVELOPING COMPANIES

ADRESSING CHANGES THROUGH MSW-LCA: SÃO PAULO AND TOKYO CASES

BUILDING MUNICIPAL CAPACITY OR STRATEGIC WASTE ANAGEMENT PLANNING

SESSION: SOCIAL AND COMMUNICATIONS ISSUES

ANALYSIS AND PUBLIC COMMUNICATION OF RATES FOR PUBLIC SERVICES

THE APPLICATION OF THE “RESPONSIBILITY PRINCIPLE” IN TWO MEMBER STATES OF THE EUROPEAN UNION
LCA AND INTEGRATED ENVIRONMENTAL MONITORING SYSTEM AS TOOLS FOR EVALUATION OF ENVIRONMENTAL IMPACT

APPLICATION OF EPR TO THE MANAGEMENT OF BUILDING’S LIFE CYCLE

FEDERAMBIENTE AND THE GREEN PUBLIC PROCUREMENT FOR URBAN HYGIENE PUBLIC COMPANIES

ENVIRONMENTAL COMMUNICATION – THE APPLIANCE ON WASTE MANAGEMENT

WASTE MANAGEMENT AND ROAD TRANSPORTATION OF DANGEROUS GOODS: COMPARING LEGISLATIONS

BUILDING A SECOND GENERATION CO-REGULATORY SYSTEM - AUSTRALIA’S NATIONAL PACKAGING COVENANT
GPP POLICIES IN THE MUNICIPALITY OF FERRARA

COST FUNCTIONS FOR MATERIAL RECOVERY AND COMPOSTING FACILITIES

RECYCLING COLLECTION CENTRES AROUND LAKE TRASIMENO: AN EXPERIMENT IN INVOLVING THE PUBLIC IN RECYCLING INITIATIVES WITH FINANCIAL INCENTIVES

ESTIMATING COSTS FOR SOLID WASTE TREATMENT FACILITIES

WASTE MANAGEMENT AND STRATEGIES OF PREVENTION

PREVENTION AND RECYCLING OF WASTE IN THE PRIULA CONSORTIUM BY PAYT CHARGE

**SESSION: CITY STRATEGIES
IN WASTE
MANAGEMENT**

STRATEGIC SOLID WASTE
MANAGEMENT IN CITIES IN
JAPAN

WASTE MANAGEMENT IN THE
MEGACITY OF SÃO PAULO,
BRAZIL: LOOKING FOR A
SUSTAINABLE FUTURE

MOVING THE RCRA VISION
FORWARD: THE NEXT
GENERATION OF WASTE
MANAGEMENT IN THE UNITED
STATES

**SESSION: DEVELOPING
COUNTRIES ISSUES
AND EXPERIENCES**

ISWM – REGIONAL GUIDELINES
IN DEVELOPING COUNTRIES OF
THE MASHREQ AND MAGHREB
REGION (METAP – RSWMP)*

SUSTAINABLE DEVELOPMENT,
FROM LOCAL TO GLOBAL,
THROUGH INTERNATIONAL
COOPERATION

INTEGRATED APPROACH FOR
SUSTAINABLE SOLID WASTE
MANAGEMENT IN SOME ASIAN
COUNTRIES

ENHANCING EFFICIENCY OF LOCAL
GOVERNMENT AUTHORITIES FOR SOLID
WASTE MANAGEMENT FACILITIES

ASSESSMENT OF PRACTICAL SOLUTIONS
PROPOSED FOR SOLID WASTE
MANAGEMENT IN PUNJAB AND
SOUTHEASTERN ANATOLIA

SOLID WASTE MANAGEMENT IN
ERZURUM AND THE WASTE UNION OF
ERZURUM

EFFECTS OF PRETREATED HOSPITAL
WASTE RESIDUES ON BIODEGRADATION
OF MUNICIPAL SOLID WASTE

SOLID WASTES MANAGEMENT IN
DEVELOPING COUNTRIES

OPTIMIZATION OF THE MUNICIPAL SOLID
WASTES SORTING AND COMPOSTING
SYSTEM IN THE CITY OF ESTRELA,
BRAZIL

SUSTAINABLE TREATMENT OF SEWAGE
SLUDGE PRODUCED BY HOTELS IN
MAURITIUS USING TWO BULKING
AGENTS

**SESSION: ENVIRONMENT
ASSESSMENT, LCA &
QUALITY**

VALUATION OF WASTE MANAGEMENT
EXTERNALITIES: A COMPARISON REVIEW
AND ANALYSIS

AUTOMATIC ENVIRONMENTAL
MONITORING OF AERIFORM
ISSUES

URBAN WASTE MANAGEMENT IN
ITALY: THE RULES GOVERNING
LOCAL AND MUNICIPAL
AUTHORITIES – BALANCES –
COMPARISONS

MUNICIPAL WASTE COLLECTION
QUALITY SYSTEM

OPTIMIZATION OF THE
INTEGRATED SYSTEM FOR THE
DIFFERENTIATED COLLECTION
OF PLASTICS, EVALUATED
THROUGH A LCA ANALYSIS

ANALYSIS OF THE MAIN
INDICATORS ON MUNICIPAL
SOLID WASTE GENERATION AND
MANAGEMENT IN ITALY

THE APPLICATION OF THE
ENVIRONMENTAL PRODUCT
DECLARATION TO WASTE
MANAGEMENT SERVICES

BIOAVAILABILITY EVALUATION
ON HEAVY METALS IN ASHES
FOR WASTE DISPOSAL SITE

POLICY EVALUATION FOR SOLID
WASTE MANAGEMENT BY WLCA
IN JAPAN

COMPARATIVE ANALYSIS OF THE
KRAKOW AND STOCKHOLM MUNICIPAL
SOLID WASTE MANAGEMENT SYSTEMS
EMAS ENVIRONMENTAL REVIEW OF A
WASTE TO ENERGY PLANT

ENERGY AND MATERIALS FLOW
MODELLING OF MSW: OPTIONS FOR
MANAGEMENT OF THE PLASTICS
FRACTION IN HOUSEHOLD WASTE

EMS AND WASTE MANAGEMENT: THE
CASE STUDIES OF TWO ITALIAN LOCAL
AUTHORITIES

THE PRODUCTION OF HIGH QUALITY RDF
IN THE PLANT AT VESTA DI FUSINA
VENEZIA

LIFE CYCLE ASSESSMENT OF A 1ST
CATEGORY LANDFILL WITH ENERGY
RECOVERY FROM BIOGAS

**SESSION: HAZRDOUS & HEALTH
CARE WASTE, RECOVERY**

EVALUATION OF ORGANIC CARBON
LEACHING POTENTIAL FROM TREATED
INCINERATOR BOTTOM ASH USING
CONVENTIONAL AND GREEN PROCESS
METHODOLOGIES

DETERMINATION OF THE BEST
APPROPRIATE MANAGEMENT FOR THE
HEALTH-CARE WASTES
IN-SITU ACCELERATED BIO-
STABILIZATION OF MSWI BOTTOM ASH
AND SHREDDED INCOMBUSTIBLE MIXES

DEVELOPMENT OF A
NEUTRALIZATION PROCESS OF
HAZARDOUS WASTES OF THE
OIL-FIRED POWER GENERATION
WITH RECOVERY OF THEIR
VALUABLE ALLOYING METALS

PROPOSAL FOR A SUSTAINABLE
HEALTHCARE WASTE
MANAGEMENT IN ANTALYA CITY

RECYCLING OF MUNICIPAL
INCINERATOR FLY ASH INTO
CEMENTITIOUS MIXES THROUGH
A PRELIMINARY
SOLIDIFICATION/STABILISATION

BROMINATED FLAME RETARDANTS IN
PLASTICS BY TIME OF FLIGHT
SECONDARY ION MASS SPECTROMETRY

PROCESS DEVELOPMENT OF RAPID
SCREENING METHOD FOR

DEVELOPMENT OF A REDUCTION
SMELTING PROCESS FOR THE
ENVIRONMENTAL MANAGEMENT OF
METALLURGICAL DUSTS

SUSTAINABLE HEALTH CARE WASTE
MANAGEMENT IN JAPAN

ANALYTICAL STUDIES USED AS TOOL TO
PROVIDE EFFECTIVE SOLUTIONS TO
BIOMEDICAL WASTE MANAGEMENT IN
CAPITAL OF INDIA

CONFERENCE ABSTRACTS**Session: Recovery and Recycling Strategies****Title: A FULL-SCALE COMPARISON BETWEEN A FOOD WASTE DISPOSER SYSTEM AND A VACUUM SYSTEM FOR COLLECTION OF SOLID ORGANIC WASTE****Author / presenter: Björn Appelqvist, bjorn.appelqvist@malmo.se****ABSTRACT**

A vacuum system and a waste disposer system used for collection of food waste in a city district in Malmö, Sweden have been compared. Comparisons are made with respect to user perception, collection and separation efficiency. Collected food waste has been analyzed with respect to composition and methane production. User perception has been investigated. Households using the vacuum system sort out 28-46 weight-% of produced food waste. The collected waste consists of 86-94 weight-% organic material. Paper and plastics are main contaminants. The waste disposer system provides high sorting efficiency and clean organic material, making pretreatment needless. Methane yield for food waste from the vacuum system and waste disposer system are 271 Nm³ CH₄/ton VS_{in} and 395 respectively. Conducted interviews show the presence of a strong norm of not discarding food. Waste disposers are positively regarded and considered to make waste handling easier. The vacuum system is regarded to increase user workload. For user acceptance users have to be informed of why to act as well as what to do. The waste disposers are more efficient for source-sorting of food waste than the vacuum system.

Larger user acceptance is the main advantage. A viable market for digestion residuals as fertilizer is crucial for sustainable food waste source-sorting.

Title: PVC RECOVERY OPTIONS, ECOLOGICAL AND ECONOMICAL SYSTEM ANALYSIS**Author / presenter: Dr. Leitner Helmuth, helmuth.leitner@solvay.com****ABSTRACT**

Eco-efficiency comprises an efficient use of raw materials, a minimum impact by emissions and waste, and an overall balance of environmental and economic benefits and burdens. To this aim, an “Ecological and Economic System Analysis” of different processes and waste recovery options was performed.

Mixed cable waste has been chosen as it represents a complex, large waste stream for PVC waste products and shows similarities with waste streams from other plasticized PVC applications.

The function of the systems under study is “processing of 1 t mixed cable waste”. The technologies generate different quantities and qualities of recovered products.

The four investigated recovery technologies can be characterized as follows:

1. The municipal waste incineration in the *MVR Hamburg* facility in Germany with the recovered products electricity, heat, HCl, and metal(s).
2. The feedstock recycling with the *Watech* process of NKT Research Center A/S in Denmark. It uses pyrolysis followed by purification and extraction steps. The recovered products are CaCl₂, coke, pyrolysis oil (condensate) and metal(s).
3. The feedstock recycling process of *Stigsnaes Industrimiljø A.S.* in Denmark is a hydrolysis followed by post-heating (pyrolysis) of the dechlorinated solid fraction. The recovered products are NaCl, hydrocarbon (C_nH_m) fractions, solid residue for the production of sandblasting material, and metal(s).
4. The mechanical recycling with the *Vinyloop* process developed by Solvay S.A. uses solvents and is based on selective dissolution, separation and precipitation of the PVC compound. The recovered products are PVC compounds and metal(s).

Landfilling was chosen as the reference option of this study, there are no recovered products.

**Title: A PROCESS OF ARTIFICIAL LIGHTWEIGHT AGGREGATES
PRODUCTION FROM ACID BOTTOM ASH WASTE OF THE LIGNITE
POWER GENERATION**

Author / presenter: Iason M. Anagnostopoulos iason@chemeng.upatras.gr

ABSTRACT

Power generation plants of Public Power Corporation (PPC) in Megalopolis (Peloponnesus) produce about 4 millions tones/year of solid wastes (75% fly ash, 25% bottom ash). It was shown in the late seventies and early eighties by the two of the authors the advantages of acid flying-ash additions to Portland cement clinker. The corresponding to this production amount of Megalopolis flying ash is in the part 10-15% of the total amount produced. Contrary due to its high carbon content (about 10%) Megalopolis bottom ash could not find utilization from cement producers. Thus a result absorption and utilization of bottom ash in other application is an urgent need.

Therefore research efforts were forced in the production of new (artificial) construction materials.

The target was to produce a low weight (high porosity) and high compressive strength new construction material by using bottom and fly ash as raw materials. Such new materials can be used as aggregates in lightweight concrete production.

**Title: POST-CONSUMER POLYETHYLENEPOLY
(ETHYLENE TEREPHTHALATE) COMPATIBILIZED BLENDS**

Author / presenter: Mauro Aglietto, aglaim@dcci.unipi.it

ABSTRACT

The aim of the work is to prepare new polymeric materials using post-consumer Polyethylene/PET compatibilised blends. The blending of virgin Polyethylene and PET allows us to obtain materials for engineering applications, as a consequence of the attractive balance of mechanical and barrier properties and of the improved processability. The properties of the blends can be modulated acting on the composition, the processing conditions and the degree of compatibility. The post-consumer materials were blended using compatibilizers consisting of polyethylene functionalized with maleic anhydride. The blends were characterized by Scanning Electron Microscopy (SEM) technique and the tensile properties were evaluated.

Preliminary results showed that morphological and tensile properties of the blends containing the compatibilizer were improved with reference to polyethylene/PET un-compatibilized blends. The improving of properties was more evident when a low density post-consumer material was employed. However the properties of virgin polyethylene/post-consumer PET blends were very similar to the properties of blends containing both post-consumer components. Therefore samples of obtained material will be tested in order to have an assessment of the market value/applications. The study was carried out in the Chemistry and Industrial Chemistry Department of the Pisa University and it was supported by the Tuscan Region Government, Co.Re.Pla (National Consortium of Producers and Users for Recovery of Plastic Packages) and Toscana Ricicla s.r.l. (also acting as Project Manager) on the basis of a general program agreement about material recovery in Tuscany.

**Title: AN EVALUATION OF RECYCLING SERVICES USING SPATIAL
ATTRIBUTES TO SUPPORT THE DEVELOPMENT OF RECYCLING
STRATEGIES**

Author / presenter: Marie K. Harder, M.K.Harder@brighton.ac.uk

ABSTRACT

The UK has the national target of recycling 25 per cent of household waste by 2005 with each individual authority being set their own recycling target. Local Authorities are therefore revising their existing recycling services and evaluating how changes in service provision could improve their performance. In this paper a method is presented using Geographic Information Systems (GIS) to evaluate the existing recycling services provided throughout Brighton & Hove City.

Recycling services were mapped allowing for an assessment of the spatial distribution and the accessibility of residents to these recycling facilities throughout the City. Three key findings are presented. Firstly, although 97% of the population had access to recycling facilities, analysis revealed parts of the City which were not covered by any service - 'recycling deserts'.

Secondly even though facilities for recycling individual materials were distributed evenly throughout the city, service provision for cardboard was limited to a small percentage of the population.

Finally some areas of similar population were served by bring banks with significantly different capacity. This research suggests that there is a need to increase recycling service provision in parts of the City with particular attention being paid to providing a service for cardboard. The results illustrate that GIS is a useful tool for waste managers and can be used to plan and develop an efficient recycling service.

Title: INNOVATIVE PROCESS CONVERTS PVC WASTE INTO RAW MATERIALS

Author / presenter: J. Procida & K.S. Bloch jprocida@rgs90.dk & ksb@cowi.dk

ABSTRACT

Recycling of PVC waste is a focus area in European environmental policy. PVC waste may hence be regarded as a potential resource instead of useless waste. Since 1998, the Danish company RGS 90 has made a great effort to develop a sustainable method for chemical recycling of PVC waste. RGS 90 has obtained financial support from the LIFE-programme under the European Union (EU) and from Vinyl 2010. The financial support has made it possible to carry out a full-scale industrial demonstration project for chemical recycling of PVC waste into oil, salt and minerals. The process has shown ability to treat all types of PVC waste in full-scale tests. With a capacity of 50,000 t/y PVC waste, the plant is erected near the Danish city of Skælskør. With the industrial size pilot plant in operation, further tests will be performed to evaluate the PVC waste pre-treatment, reactor performance and product refining processes.

The combination of dechlorination of PVC by hydrolysis and the successive pyrolysis of the dechlorinated solid fraction has already shown environmentally improvements creating a liquid product with low chlorine content and 100% utilisation of the PVC waste.

**Title: FROM WASTE MANAGEMENT TO RESOURCES MANAGEMENT:
MATERIAL FLOW ANALYSIS - A TOOL TO IMPROVE
WASTE MANAGEMENT DECISIONS**

Author / presenter: Paul H. Brunner paul.h.brunner@tuwien.ac.at

ABSTRACT

This paper demonstrates how Material Flow Analysis MFA can be used to improve decisions in waste and resources management. In four comprehensive research projects, the total flows and stocks of wastes, construction materials, aluminium and nitrogen are assessed, taking uncertainties as well as missing or “bad” data into account. Various strategies to reach the goals of waste management, namely “resource recovery” and “protection of men and environment” are investigated. The results show the relevant mass flows and stocks in view of resource conservation and long-term environmental protection.

Material Flow Analysis proves to be highly useful to early recognise future resource potentials and environmental loadings and to set priorities in resource recovery and waste management. Effective and non-effective recycling concepts and measures are identified. New, long term resource management strategies are introduced that allow more economic and less polluting use of materials and wastes.

It is proposed to shift systematically to “urban mining”, that is the design of anthropogenic systems in view of future extraction and reuse of secondary resources, and to gradually decrease primary ore mining.

Title: WASTE GENERATION AND MANAGEMENT IN ITALY

Author / presenter: Giorgio Cesari, cesari@apat.it

ABSTRACT

With the aim of monitoring the enforcement of the waste legislation, every year, since 1997, the Agency for the Protection of the Environment and for Technical Services (APAT), publishes a topic report about waste generation and management in Italy (Rapporto Rifiuti), in collaboration with the National Observatory on Waste. This paper is a summary of the Rapporto Rifiuti 2003 and it illustrates the state of the art of waste generation and management in Italy from 2000 till 2002. The issuing of the Rapporto Rifiuti is based on the elaboration of data on waste generation and management included in the National Waste Register; the Register has its headquarter at the Waste Unit of APAT and has regional seats at Regional Environment Protection Agencies (ARPAs). Data are collected annually by means of a compulsory survey addressed to all the subjects involved in the waste cycle, from production to disposal.

Title: THE REVAMPING OF THE COMBUSTION PLANT OF AAMPS IN LIVORNO FOR RDF (REFUSE DERIVED FUEL)

Author / presenter: A. Canovai, secit-ecologica@secit-ecologica.it

ABSTRACT

This paper describes the reconstruction work that has been done at the incineration plant for urban solid waste in the city of Livorno. The aim of this work was to convert the plant into a combustion plant for refuse derived fuel (RDF). The paper contains the description of the work carried out and some of the calculations regarding the process and dimensions. Some of the equipment (especially for the thermal cycle) has been replaced.

The steam generator has also been enlarged, according to the same conditions as the part concerning the superheater and the economizer. The calculations regarding the combustion chamber are included in the paper, taking into consideration the particularities of the grid cooled to water.

Title: FOR A BETTER PLASTIC RECYCLING: A PARTNERSHIP WITH ACRR**Author / presenter:** Jean-Pierre De, JP.Degreve@plasticseurope.org**ABSTRACT**

The European PVC industry recognises the need for a strong commitment to achieving sustainability as a part of its own role in modern society. It has developed an integrated approach, set out in a Voluntary Commitment¹ and managed through Vinyl 2010, with medium-long term projects and actions covering:

- PVC manufacture.
- Additives – plasticizers and stabilisers.
- Waste management.
- Social progress and dialogue.

Waste management includes 18 projects: sector recycling targets; development of mechanical and feedstock recycling, incineration and other recovery processes, studies and researches.

One of these projects is a Partnership Agreement with the Association of Cities and Regions for Recycling (ACRR) in order to: improve the recycling of plastic waste collected by local authorities, define a communication strategy and develop tools to improve the collection of selected types of plastic waste. Pilot projects in Catalonia and the region of Porto have been run.

The project defined a communication strategy including a best practice guide.

A follow-up project on collection and recycling of plastic waste from buildings in Italy, Spain, Portugal and Belgium has been presented to the EU Commission under the LIFE programme. At a later stage it will entail 20-30 pilot projects covering a wide spectrum of activities.

**Title: ACTIVATION OF A SEPARATE WASTE COLLECTION SERVICE
IN SMALL RURAL CENTRES. RESULTS AND FUTURE PROSPECTS****Author / presenter:** G. Sassaroli, leombruni@sia.pg.it**ABSTRACT**

The paper describes the action taken by the local authorities of Marsciano, S.Venanzo, Collazzone, Deruta, Fratta Todina and Giano dell'Umbria (about 36,000 inhabitants), situated in rural areas south of the regional capital Perugia, with the aims of fulfilling regional plans for separate waste collection.

The system adopted consists of the placement of small bins (240 litres) near habitations for the separate collection of paper and board, glass, and plastic. Composters have been provided for domestic recycling of organic waste (kitchen and garden waste). For larger users (supermarkets, shops, canteens), personalised collection systems have been adopted.

Particular attention has been paid to publicity and information in the local communities, not only through the tradition systems of communication (leaflets, posters etc.), but also through meetings and conferences in local centres for the direct involvement of residents, local authorities and companies responsible for urban cleansing services. In the few months since it was started up, the project has had interesting results in terms of quantity and quality of material collected. This has encouraged administrators and the S.I.A. company to continue the experiment in order to reach the objective of the recycling of 35% of household waste, an objective which has almost already been reached.

Title: SUSTAINABLE WASTE MANAGEMENT BY AN INTEGRATED SOLID WASTE TREATMENT PLAN IN FRIESLAND, THE NETHERLANDS

Author /Presenter: Ton Doppenberg , Thijs Oorthuys and Luchien Luning,
t.doppenberg@afnv.nl, thijs.oorthuys@grontmij.nl

ABSTRACT

The 220,000 tonnes per year SBI-plant (Friesland, the Netherlands) to treat residual MSW consists of an integrated mechanical separation unit and a washing and digestion unit that processes OFMSW (the organic fraction recovered from MSW). Start-up of the plant was end 2002. The washing and digestion unit caused various technical and operational problems that had to be resolved. Particularly, optimisation of the washing process improved the operational availability of the entire washing-digestion unit considerably. Practical experience gained so far shows that the initial goals set for the plant with respect to material and energy recovery are met.

Ongoing developments, in particular lowering the costs for final disposal of RDF, paper and plastics recovered from MSW, show a trend to further reduce the overall treatment fee.

Title: CHARACTERISTICS OF ECO-FRIENDLY POTS MADE FROM *SHOCHU* DISTILLATION LEES

Author /Presenter: Masahito Yamauchi, Sumio Masuda, Megumi Mihara,
yamauti@kagoshima-ct.ac.jp

ABSTRACT

To provide an effective and urgently needed utilization of *shochu* lees, we have incorporated them into environmentally friendly paper pots (hereafter called Eco pots), and have clarified their physico-chemical characterizations. To discover whether the Eco pots are an effective agricultural material, we carried out a growth test of mini tomatoes using them. In addition, we buried samples taken from the sides of the Eco pots in the soil as a material test to clarify the degradation characteristics of the pot in the soil. We found that the Eco pots kept their shape without disintegration when transplanted to the field. After transplantation, the roots of the test plants penetrate through the Eco pot and radiate widely throughout the soil. The Eco pots had a clear fertilizing effect. After burial in the soil, the Eco paper's tensile strength decreased rapidly, such that when 5 months had passed, it disintegrated easily. The time needed for the Eco paper to completely disappear in the soil was about two years.

Title: END-OF-LIFE VEHICLE RECYCLING: THE VOLKSWAGEN-SICON-PROCESS FOR THE RECYCLING OF SHREDDER RESIDUES**Author /Presenter: Heiner Guschall, Sebastian Schülke, Dr. Daniel Goldmann,**
s.schuelke@sicontechnology.com**ABSTRACT**

European Union lawmakers have extended product responsibilities of car manufacturers beyond the end of the useful life of their products and have established high recycling rates for ELVs, which will take effect in 2006 or 2015 respectively. Regulatory requirements on the European level as well as on the national level of member states together with implementation of technical processes for the recycling of ELV's pose considerable challenges for both the recycling and the automotive industry.

Initially, manual dismantling of vehicle parts was the solution most industry insiders favoured. For reasons of cost-effectiveness however, this option is not feasible in wage intensive countries. In addition, this method produces secondary materials for which exist only limited markets. Therefore, the main focus of all activities aimed at meeting the established recycling rates in a cost-effective manner is the development and implementation of processes with minimum manpower assignment to recover recyclable fractions of the waste currently disposed of in landfills. We need to find intelligent recovery solutions fitting the technical know-how of an industrialized Europe.

As a result, since the fall of 1999, Volkswagen in cooperation with SiCon is working on the development of a process to achieve a user-oriented production of recyclable materials by mechanically processing shredder waste. The process consists of a processing and a recycling phase. Processing, mainly aimed at material recycling solutions, considers the requirements of existing industrial-scale recycling operations. During implementation planning, potential buyers of recyclable materials, already familiarized with the concept over a period of years through intensive canvassing, and shredder plant operators are brought together. This ensures markets for the products and guarantees recycling.

By stage crushing, classification and separation based on physical parameters such as specific gravity, grain shape, magnetizability, electrical conductivity and optical properties, more than 75 % of shredder waste can be converted into recyclable fractions.

Specific process steps produce the following fractions:

“Shredder Granules (hard plastics, rubber).

“Shredder Fibres” (foam, textiles).

“Shredder Sand” (glass, rust, iron particles, heavy metals) for which applications have already been studied and field-proven.

The Volkswagen-SiCon-Process has been specifically developed for shredding of ELVs, but may as well be applied for shredder residues from other sources. In close cooperation with the recycling partners, the process is to be implemented EU-wide in order to create a sustainable solution which will accomplish the environmental objectives at acceptable cost. A reference unit is currently in the planning phase in order to offer the market a technology based on market-oriented solutions.

Title: PRE-TREATMENT – TOWARDS INTEGRATED WASTE MANAGEMENT**Author /Presenter: M. Fontana-Giusti****ABSTRACT**

Today EU is facing a risk of shortage in treatment capacity. Landfill diversion targets coupled with technical acceptance criteria prior to recycling and alternative energy recovery facilities are main drivers for pre-treatment development. Furthermore increase in treatment costs along with the risk of capacity shortage are making pre-treatment profitable with existing treatment assets. Pre-treatment is therefore becoming a main step in an increasingly downstream driven business. The optimal combination, technical as well as economical, between collection, waste processing and treatment has to be found: technical, to meet the final requirements for the end products prior to re-use, recycling or specific treatment; economical, to be sustainable.

Title: VINYL 2010: THE VOLUNTARY COMMITMENT APPROACH OF THE EUROPEAN PVC INDUSTRY TO THE CHALLENGE OF SUSTAINABLE DEVELOPMENT**Author /Presenter: Martyn Griffiths, martyn.griffiths@apme.org****ABSTRACT**

One of the most promising approaches to bridge corporate and government roles toward sustainability are Voluntary Commitments (VC) by industry.

Vinyl 2010, involving the entire industry, from raw-material production to post-consumer waste, sets out commitments on production, additives and waste management and operates through projects covering technology, research, organisation and communication. Vinyl 2010 has established a Monitoring Committee with representatives from the European Parliament, the European Commission and trade unions. The Vinyl 2010 initiative takes on even further significance in the context of an enlarged EU with 25 or more member states. VCs are an efficient way of transferring best practice.

Title: HEAVY METALS REMOVAL FROM AUTOMOBILE SHREDDER RESIDUES (ASR)**Author /Presenter: Keisuke Kurose, Tetsuji Okuda, Wataru Nishijima, Mitsumasa Okada, keikuro@hiroshima-u.ac.jp****ABSTRACT**

The fate of heavy metals in a separation process of automobile shredder residues (ASR) was investigated. The washing method in order to remove heavy metals from the residue of ASR was also investigated.

Although the separation process was not designed for heavy metal removal but for the recovery of reusable materials, the contents of heavy metals in ASR efficiently decreased, and the contents of As and Pb satisfied with the EQSS by the separation process. Percent removal of As and Pb by the separation process from the residue-A to D were 100 and 92 wt%, respectively.

The concentrations of As, Se and Pb in the leachate from the residue of ASR were still approximately 3, 4 and 8 times higher than the Environmental Quality Standards for soil (EQSS) for elution, respectively. The concentrations of As, Se and Cr in ASR were reduced by the removal of nonferrous metals (aluminum, copper), and Pb and Cd were reduced by the removal of “woods, fibers, urethanes and sediments” in the separation process. The concentrations for all three metals could satisfy with the EQSS for elution after the washing by acid buffer solutions at pH 1. These results indicated that the residue of ASR after the separation followed by the washing at acidic pH can be recycled safely.

Title: TECNOLOGY AND EXPERIENCE IN THE TREATMENT OF INERT MATERIALS AFTER THE EARTHQUAKES

Author /Presenter: M. Marionni M. Sportolari, M. Valentini,
ecologia@regione.umbria.it

ABSTRACT

The problem of the re-use of inert materials from the demolition of buildings has prompted various initiatives on the part of the Region of Umbria for the resolution of this problem. The earthquakes which affected the Apennine region of Marche and Umbria in 1997 caused enormous problems for the treatment of construction materials from demolition sites, but previous experience meant that our Region was not unprepared in facing this problem. The paper describes the initiatives taken in response to the problems caused by the earthquakes, and now the critical phase has passed the experience in dealing with the problem can still be of advantage to the whole community for the efficient re-use of materials and for a reduction in quarrying activities.

Title: WHY ARE NOVEL TECHNOLOGIES NOT MAKING AN IMPACT ON THE PROCESSING OF POST-CONSUMER WASTES?

Author /Presenter: Kevin J. Whiting and Joseph Schwager
whiting@juniper.co.uk

ABSTRACT

The last ten years have seen many new proprietary technologies being developed for specific applications within the waste management industry. Gasification, pyrolysis and mechanical biological-treatment (MBT) processes have all been promoted as a ‘better’ solution for maximising recycling and offering sustainable options for managing household waste. By providing an alternative to politically unpopular incineration, such solutions have been viewed as attractive by both the public and politicians.

Yet, after much development effort and some high-profile demonstrator projects, none of these solutions have so far succeeded in displacing conventional technology solutions. This paper reviews the progress of novel technologies towards commercialisation, provides a dispassionate re-appraisal of the benefits provided by non-conventional systems and identifies limiting factors that are slowing or preventing the adoption of such processes. We will report on recent research and analysis conducted by Juniper concerning the changing needs of the market, different geographical drivers, the need to match outputs from a process to real and stable end-user market outlets, the potential impact of induced fiscal and trading initiatives related to climate change and the technology risk that will make a process 'bankable', particularly related to the increasing role of the risk-averse private sector in the funding of new waste management infrastructure.

**Title: BEYOND RECYCLING TO SUSTAINABLE
PRODUCTION & CONSUMPTION**

Author /Presenter: **Ian Coles Chief Executive Officer & Jon Ward**
www.ecorecycle.vic.gov.au

ABSTRACT

EcoRecycle Victoria is the State government agency working to reduce waste to landfill and to promote the sustainable use of material resources. Targets established for the next ten years, seek to increase recycling from around 50 % of the waste stream to 75 % and for total waste generation to be reduced by 15 %, through the decoupling of waste and growth. This later aim is one now being embraced by developed countries and international agencies recognising that recycling and closing the material loop, still results in greater and greater quantities of materials circulating in the economy and is not ultimately sustainable. Materials efficiency and dematerialisation are not new concepts and significant improvements have already been achieved in production and consumer products. However what history shows us is that despite efficiency gains, most measures of sustainability are still on the increase due to the dominating effects of consumption. If the production and consumption cycle is to become a sustainable and if we cant outpace consumption, then we have to do something radically different.

From the perspective of a resource agency it is imperative to be able to communicate this new direction clearly and to then build programs which will shift behaviour in that direction. The production and consumption cycle is made up of a number of key stakeholders, designers, suppliers, producers, retailers, consumers and end of life managers. Materials efficiency is the dematerialisation of any of these sectors. But sustainable production and consumption is broader and relates to the optimisation of the entire system collectively to achieve a dematerialisation of the product/ service system provided to the consumer. Achieving this outcome requires new communication channels and relationships, a shared approach across the production and consumption cycle to life cycle strategies and a common focus on the commodity which is common to all stakeholders, not the waste nor material inputs, but product focused strategies and programs.

Session: Treatment of Biowaste

Title: POLICY EVALUATION FOR SOLID WASTE MANAGEMENT BY WLCA IN JAPAN

Author / presenter: Masaru Tanaka, maxta@cc.okayama-u.ac.jp

ABSTRACT

Solid waste management (SWM) system is oriented towards its contribution to sustainable society. At this juncture, it has been felt necessary to evaluate the environmental consequences of various SWM options so as to adopt environmental friendly technologies for waste management. In order to perform quantitative analysis, recourse has been taken to LCA techniques. A PC based software, developed for this purpose, has been modified to facilitate its use by professionals working in waste management. Basically, in keeping with the local constraints, alternative scenarios would be formulated. The software would be used to quantify the environmental impacts, resource recovery and expenditure for each scenario. This quantification would help in decision making while selecting a particular scenario. The proposed methodology is validated for the real life situation of Okayama city. In this paper, various details of the analysis including WLCA software, its modification and its validation through case study would be discussed.

Title: THE AF-BNR-SCP PROCESS: FOCUSING ON THE ANAEROBIC CODIGESTION STEP OF SEWAGE SLUDGE AND OFMSW IN THE FULL SCALE EXPERIENCE OF AN OFMSW/WASTEWATER INTEGRATE TREATMENT.

Author / presenter: Paolo Pavan

ABSTRACT

The paper describes a process developed on pilot scale in the years 1994-1998 and then transferred on full scale in 2000 at Treviso plant. The basic idea is to integrate waste and wastewater treatments using low-chain products from the AF process as promoters for denitrification and P removal steps in the BNR process and applying the codigestion of OFMSW and sewage sludge. This approach, widely experimented, has brought to important results in terms of energy recovery. The plant can treat up to 20.000 m³/d of civil wastewater, and, at the same time, up to 20 tons/d of OFMSW coming from Treviso municipality where wastes separate collection is currently applied. The plant has been monitored since its start up. The obtained results confirm pilot scale indications and, focusing on the energy aspects, they sometimes overcome the predicted yields. The SGP for OFMSW, estimated on a mass balance basis, gives values of 0.7-0.8 m³/kgTVS_{feed}, which are very high considering the initial quality of the collected OFMSW. In terms of biogas production enhancement, this means that, in this plant, it increased from 4-5.000 m³/month (produced using only secondary sludge) to roundabout 20.000 m³/month.

Title: SIGNIFICANCE OF source separation and COMPOSTING of wastes of ISTANBUL : FROM THEORY TO PRACTICE**Author /Presenter:** Gökce A. Aydın, akgoze@boun.edu.tr**ABSTRACT**

The municipal waste composition of a country can reflect its level of development. Organic wastes together with the recyclables are successfully diverted from the waste stream whereas for the developing countries, this is still a big challenge. Turkey is an economically developing country with some very unique specialities, such as being a bridge between Europe and Asia and having a leading status for the other economically developing countries in the region. The handling of organic wastes is a new trend for the city of Istanbul and there are a lot of operational and managerial difficulties in the application. Since the contributors of waste management are both the generators and collectors, the problem will be examined both from the point of view of the residents and the municipality. The current situation of solid waste management for the city of Istanbul will be given in the article and suggestions for better administrative practices will be provided.

Title: USE OF STABILISED BIOWASTE IN CLAY QUARRY ESTORATION: MONITORING OF ENVIRONMENTAL EFFECTS**Author /Presenter:** Lorella Rossi , Paolo Mantovi, p.mantovi@crpa.it**ABSTRACT**

The environmental effects resulting from the addition of stabilised biowaste to quarry clay materials, to obtain suitable substrates for quarry restoration, were evaluated in experimental plots with different rates of stabilised biowaste (up to 500 DM t ha⁻¹, mixed to a depth of 115 cm) combined with clay quarry materials. The plots were equipped with tensiometers, ceramic cup samplers and systems for gathering run-off water. The agronomical characteristics of the substrates, along with their vegetation covers, were improved by increasing the stabilised biowaste rate, but the high silt content, together with the high natural sodium content, rendered the substrates nonetheless low-structured and low permeable. As a consequence, water infiltration was very limited, whilst run-off volumes from precipitation were higher. The concentrations of nutrients, organic matter and heavy metals measured in these waters and within the substrates, were below the risk levels prescribed to protect the environment, even for the maximum amount of stabilised biowaste tested.

Title: BIOLOGICAL HYDROGEN PRODUCTION BY THE ANAEROBIC FERMENTATION OF SOLID WASTES**Author /Presenter:** Héctor M. Poggi-Varaldo, Idania Valdez-Vázquez,
Noemí Rinderknecht-Seijas, hectorpoggi2001@yahoo.com**ABSTRACT**

This review concentrates on three areas of research on H₂ biological production carried out by our Group in the last 10 years: (i) the study of batch, cycled fermentation of paper mill wastes, (ii) batch, cycled fermentation of the organic fraction of municipal solid wastes (OFMSW), and (iii) the semi-continuous, acidogenic fermentation (DASSA) of the OFMSW. Inocula from mesophilic, methanogenic solid substrate anaerobic digestion (DASS) reactors were transferred to small lab scale, batch reactors. Milled paper (used as a surrogate paper waste) was added as substrate and acetylene or bromoethanesulfonate (BES) was spiked for methanogenesis inhibition. Acetylene at 1% v/v in the headspace was as effective as BES in inhibiting methanogenic activity. Most important, venting and flushing the headspace of the minireactors allowed for subsequent cycles of hydrogen production. The total cumulative hydrogen harvested in the three cycles was nearly double than that in the first cycle alone. We coined this procedure with the acronym IV-SSAH (intermittently vented, solid substrate anaerobic hydrogen generation). In other experiments, the IV-SSAH of the OFMSW was carried out for evaluating the effect of the inocula type (meso and thermophilic methanogenic digestates), inhibition of methanogenesis (acetylene and heat shock pretreatment HSP), and incubation temperature (37°C and 55°C). Acetylene was more effective than HSP on the average, and incubation at 37°C gave the highest hydrogen accumulation in the batch reactors. The origin of inocula did not have a significant effect on hydrogen production. A third experiment was performed with semi-continuous acidogenic solid substrate reactors fed with OFMSW (DASSA) operated in meso- and thermophilic regimes. Both the thermophilic and mesophilic DASSA using the OFMSW seem to be attractive for hydrogen generation. The thermophilic reactor achieved the highest H₂ yields and percentages. This was also accompanied by a higher biogas productivity and a stable hydrogen-generation operation.

Title: MONITORING OF COMPOSTING PROCESS BY THE DETERMINATION OF DYNAMIC RESPIRATION INDEX (DRI) AND SOME CHEMICAL-PHYSICAL PARAMETERS AT THE VESTA PLANT OF VENICE**Author /Presenter:** Paola Cossettini, Pietro Paoli, Lorena Franz,
Luca Paradisi, Francesco Codato, p.cossettini@vestaspa.net**ABSTRACT**

Dynamic Respiration Index (DRI), pH, moisture, TOC, ammonia nitrogen, TKN, C/N ratio and total volatile solids (TVS) permit to assess the development of organic matter decomposition during the process, in order to assure the production of high quality compost in terms of agronomic characteristics, environmental compatibility and biological stability.

Such monitoring becomes necessary to establish the correct operating conditions and management practices of a composting plant, required to produce high quality compost suitable for the market. The monitoring results permitted to obtain information to improve the process management of the different phases: mixing of input materials, active phase in bioreactor and curing phase, by acting on the process procedure (air addition, moistening, turning off of piles etc.). The monitoring activities were carried out during about one year at the composting plant of Vesta firm, which collects and recovers the municipal solid waste (MSW) of the Province of Venice.

Title: INNOVATIVE TECHNOLOGIES FOR BIOLOGICAL TREATMENT OF BIOWASTE

Author /Presenter: **Pietro P. Cella Mazzariol, Gian F. Galanzino**
cella@entsorga.it

ABSTRACT

Plants devoted to the treatment and recovery of waste characterised by a putrescibile organic content find their value increased in the compliance with environmental and agronomic regulations, in the capacity to drastically reduce microbiological risks present in waste and in minimising the emissions deriving from biological activity (odours, VOC, airborne microorganisms). In this work the results obtained thanks to the latest technological Entsorga Italia developments are summarised in the fields of waste stabilisation and high calorific waste derived fuel recovery; by means of customised reactors, wastes are successfully sent to an aerobic biological treatment able to drastically reduce both its residue biological activity and at the same time microbiological pathogen concentration, with lower and lower energetic and economic costs. Performances are shown by means of Dinamic espirometric Index evaluations before and after biological treatment, together with economic and energetic considerations; microbiological risk reduction was monitored using three groups of microorganisms as pathogen markers (*E. coli*, Faecal streptococci and *Salmonella sp.*). As far as air pollution is concerned, as a consequence of recent emerged issues related to exhausted air streams from waste treatment facilities, together with traditional biofiltration a new kind technology, based on adsorption/desorption cycles with cathalytic oxidation of the desorbed organic compounds, has now been developed to arrive at a cost competitive air cleaning system which can guarantee better performances in terms of VOC and airborne microorganism control. preliminary results of the efficiency of such technology are summarised in terms of VOC and microorganism abatement.

Title: FACTORS AFFECTING THE TREATMENT OF MUNICIPAL SOLID WASTES (MSWs) IN SIMULATED ANAEROBIC RECYCLED REACTORS: SHREDDING AND COMPACTION

Author /Presenter: Osman Nuri A_da Delia Teresa Sponza Hülya Atalay
o.agdag@deu.edu.tr, delya.sponza@deu.edu.tr, hulya.atalay@deu.edu.tr

ABSTRACT

In this study, the effects of shredding on the anaerobic treatment of domestic solid waste and leachate characteristics were investigated in three simulated landfill anaerobic bioreactors. All of the reactors were operated with leachate recirculation. One of them was loaded with raw waste (control reactor); the second reactor was loaded with shredded waste having a diameter of 0.5-1cm (shredded reactor); the third reactor was loaded with compacted waste (compacted reactor) in order to compare the effects of shredding and compaction of solid wastes. pH, chemical oxygen demand (COD), volatile fatty acids (VFA), ammonium nitrogen (NH₄-N) concentrations; total and methane gas productions in the leachate samples were regularly monitored. After 57 days of anaerobic incubation, it was observed that the pH, COD and VFA concentrations in the leachate of shredded reactor were better than the control and compacted reactor. It was observed that the waste shredding increased the methane percentage in the anaerobic simulated reactor. It was found that municipal solid wastes (MSWs) having small size exhibited fast biodegradation. It was observed that waste shredding reduced the waste quantity, the organic content of the solid waste and the biodegradation time.

Title: REVAMPING OF CARPI COMPOSTING PLANT

Author /Presenter: Adelmo Bonvicini , Elisa Semeghini,
elisa.semeghini@aimag.it

ABSTRACT

The project concerns the execution of works for the purpose of upgrading the technological, functional and operating requirements of the municipal solid waste sorting and composting plant located in the Municipality of Carpi, Fossoli place, Via Valle, 21. The revamping project includes the execution of a new section of reception, mixing and biooxidation (provided with blown-in tunnels) to replace the existing one. Mixture maturation, screening and final storage will take place by using the existing fixtures, part of which will be later employed for processing operations of the other treatment line. The new modern structure is going to:

- Optimise and standardize the running of the process.
- Implement systems for a greater control and adjustment of processing conditions (also in order to be acknowledged for the treatment of by-products of animal origin destined for human consumption in compliance with regulation CE 1774/2002.
- Obtain a product that is more stable and homogeneous in time, optimise handling and logistics of materials and means.
- Ensure a high level of respect for the environment as to the propagation of odour emissions, recycling of treated wastewaters, levels of ambient noise, soil protection and visual impact.

Title: HOUSEHOLDER ATTITUDES TO WASTE MINIMISATION THROUGH HOME DIGESTION OF BIODEGRADABLE WASTE**Author /Presenter: Matthew L Bench, Ryan Woodard, Marie K. Harder and Nikolaos Stantzos, m.l.bench@bton.ac.uk****ABSTRACT**

A survey of householder attitudes and experiences of a trial for minimising household food waste from waste collection in the county of West Sussex, UK is described. The minimisation method used the Green Cone digester, designed for garden installation. A postal questionnaire was distributed to 1,000 householders who had bought a cone during the trial and a total of 433 responses were received. The main reason for people buying the Green Cone had been concerns about waste (88%) with 78% and 67% of respondents respectively claiming to have participated in recycling and home composting in the last 30 days. The waste material most frequently put in the digester was cooked food (91%), followed by fruit waste, vegetable matter and bones/ meat. Some respondents were using it for garden and animal waste from pets. Approximately 60% of respondents had seen a reduction in the amount of waste they normally put out for collection of 25-50% with analysis showing reported reduction to be significant ($p < 0.05$). The results showed that most users found the Green Cone performed satisfactorily and saw a reduction in the amount of waste they put out for collection.

Title: BENCHMARKING OF QUANTIFICATION AND SEPARATION TECHNIQUES FOR HEAVY METALS IN LEACHATE FROM LAB-SCALE LANDFILL**Author /Presenter: E. Beccaloni, M. R. Boni, L. Musmeci, S. Scaffoni, E. Stacul, suolo@iss.it****ABSTRACT**

The present survey has the goal of benchmarking different treatment methods of leachate, in order to stress their influence on quantitative analysis of inorganic micropollutants (in particular Cd, Cr, Cu, Ni, Pb and Zn), both on liquid phase and suspended solids.

Leachate investigated has been produced by a lab-scale landfill built up with MBPs wastes; a proper characterization of the organic solid waste has been carried out, by a chemical and microbiological point of view.

Following treatment procedures used to quantify and separate heavy metals have been considered: mineralization of leachate with Aqua Regia at two different pressure and temperature values, centrifugation at 8000 rpm and filtration by cellulose membrane with net light of pores at 0,80 μ m.

First results have shown that high-pressure mineralization process is inclined to produce outcomes slightly affected by operative drawbacks, whereas significative differences have been found between centrifugation and filtration methods. The last one, infact, allows to separate heavy metals more efficiently then centrifugation step, providing higher percentage of recovery.

Title: SUITABILITY OF THE SOUR TEST TO ASSESS STABILITY IN COMPOSTS PREPARED WITH OLIVE OIL INDUSTRY WASTES

Author /Presenter: Sari T. Urpilainen, M^a Luz Cayuela, Ed I. Stentiford, Asunción Roig and Miguel A. Sánchez-Monedero*
monedero@cebas.csic.es

ABSTRACT

The suitability of SOUR as a stability test for composts containing a high proportion of fat was evaluated by using two composting mixtures prepared with different proportions of olive oil industry wastes. Fresh and air dried samples of the mixtures were tested at four different stages of the composting process (initial mixtures and after 10, 20 and 36 weeks of composting). SOUR analysis was also carried out on air dried samples after removing the fat by extraction with diethyl ether. The SOUR values obtained for fresh samples of the initial mixtures showed unusual low values between 0.2 and 0.7 mgO₂/gVS/h, that usually correspond to well stabilised organic matter. However, air dried samples of the same mixtures showed the typical SOUR (up to 3.0 mgO₂ gVS-1h-1) for this kind of materials. Air drying caused a 24 hour delay in the usual time necessary to reach the maximum SOUR, that usually takes between 8 and 12 hours in fresh samples. Fat removal from air samples did not show a clear effect on SOUR performance.

Previous air-drying of the samples was proposed for composting mixtures containing a high proportion of fat, even though the running time of the test was extended for 24 hours. Further research is proposed to understand and overcome the effect of fat content on SOUR test.

Title: PCDD/F EMISSIONS FROM BIO-MECHANICAL MSW TREATMENT FACILITIES

Author /Presenter: A. Franzinelli, M. Ragazzi, M. Tubino
Marco.Ragazzi@ing.unitn.it

ABSTRACT

In most cases MSW (Municipal Solid Waste) management is based on an integrated approach characterized by a combination of different treatment processes. When considering environmental impacts of a waste treatment facility, it is important to assess the combination of all the processes involved: this is for example the case with respect to PCDD/F emissions from RDF (Residue Derived Fuel) production and combustion: today most of RDF incineration facilities are submitted to emission control and environmental impact assessments because of incineration process is singled out as a “dirty” technology on the basis of pollutants release into atmosphere; on the contrary, some emissions from a BMT (Bio-Mechanical Treatment) treatment plant are generally no evaluated, because of the common assumption that low-temperature processes (in particular biological processes) are “clean” with no significant pollutant emissions into atmosphere.

European scientific literature has been collected, in order to estimate PCDD/F emission from BMT plants; besides, a laboratory study was carried out to estimate PCDD/F concentration and emission factor in the raw exhaust air emitted from a MSW bio-drying process in pilot scale: three trials, carried out with different airflow rate and length, showed that data obtained are in accordance with German and Austrian technical literature.

Title: STATE OF THE ART OF BIODEGRABABLE WASTE MANAGEMENT IN ITALY**Author /Presenter:** Rosanna Laraia, laraia@apat.it**ABSTRACT**

This work is aimed at illustrating the state of the art of biodegradable waste management in Italy, showing the important role played by this type of treatment in the integrated waste management cycle. According to the recent EU Strategy on the prevention and recycling of waste, preventing and recovering waste are important elements of a comprehensive approach to resources management, aiming at reducing the overall impact of resources use at all the stages of their life-cycle. On one hand the agricultural sector needs a long term supply of nutrients and organic matter, that contribute to the formation of humus in order to compensate for the losses through mineralization; on the other, the compost, which derives from the recovery of biowaste, is a good provider of well stabilised organic matter with soil improving properties (i.e. water retention capacity, physical stability, reduced erodibility). The implementation of the Landfill Directive 1999/31/EC into the national law, through the Dlgs 36/03, forces to transfer the biowaste to other specific treatments, increasing the recovery of the organic matter. This enables to decrease the gaseous emissions connected with the landfill disposal of biodegradable waste.

Title: BIOLOGICAL STABILITY AND ODOURS PRODUCTION DURING BIOLOGICAL TREATMENT OF MUNICIPAL SOLID WASTE**Author /Presenter:** Adani Fabrizio, D'Imporzano Giuliana , Ubbiali Cesare, Crivelli Fernando, Della Campa Marcello
fabrizio.adani@unimi.it, pca.tech@tiscali.it**ABSTRACT**

Waste recycling and proper biomass management need a careful odour control and monitoring, due to environmental and social impacts.

In this work six different organic matrices underwent biological stabilization process in adiabatic respirometer apparatus where oxygen uptake rate was continuously detected, being oxygen uptake rate expressed as Dynamic Respiration Index (DRI) a good parameter to describe aerobic process and to assess biological stability. In the same time odours production was measured and processed by Principal Component Analysis (PCA).

Respiration index values compared to odours measurements showed very significant linear correlation, i.e. it was found a correspondence between the degree of biological stability of the materials and their odour production. Different stabilization process phases produce various degradation products and dissimilar volatile molecules. As a result of high correlation proved between DRI values and odours productions we assume that DRI could be used as indirect index of environmental odour impact.

Title: TECHNICAL AND ECONOMIC ASSESSMENT OF QUALITY COMPOST PRODUCTION FROM AGROINDUSTRIAL WASTE

Author /Presenter: **Riccardo Melloni, Alessandro Bagnoli, Marco Bergonzoni**
alessandro_bagnoli@yahoo.it

ABSTRACT

The purpose of this study is to appraise technical, economical and environmental limits for producing quality compost from agroindustrial sewage sludges.

Sludges average chemical composition has been set through a survey on a sample of industries located in two north-Italy provinces, fixing a mixing plan consistent with laws in force. Sensitive analysis regarding process parameters depending on the processing capacity of the composting plant has been performed, through the creation of a parametric model of the installation. The composting systems considered were the following: static, static aerated, dynamic human operated turning roller, dynamic with automated turning roller.

The economics of sewage sludges recovery through composting have been examined, optimizing plant location depending on sludge production sites.

The study allowed fixing the most suitable plant configuration for composting the specific waste considered, as regards the environmental protection and the technology level necessary for the proper and efficient evolution of the biological process. For every composting system analyzed it has been defined the economically optimal field of employment. The research shows that the composting process is strongly influenced by economies of scale, emerging as an economically sustainable solution only if the amount of sewage sludge treated exceeds a minimum threshold.

Title: CRITERIA FOR ASSESSING LIQUID WASTE TREATABILITY IN MUNICIPAL WASTEWATER TREATMENT PLANTS

Author /Presenter: **G. Bertanza, C. Collivignarelli, giorgio.bertanza@unibs.it**

ABSTRACT

In Italy, accordingly with the Legislative Decree 152/99, municipal wastewater treatment plants (WWTPs) are allowed to receive liquid wastes (that is landfill leachate or in general wastes from industrial activities, driven by truck to the treatment facility) provided that the two following conditions are satisfied: 1. wastes are compatible with the plant and the biological process; 2. plant residual capacity (to be determined on the basis of actual influent loading) is not exceeded. Nevertheless, no official criteria for assessing these conditions have been established yet. In this paper, a methodological approach, which takes into account several involved technical aspects, is proposed and an example of application is described. The case study deals with an activated sludge treatment plant (global volume of biological reactor: 16.000 m³) which is provided with a facility for industrial wastes pre-treatment, including an anaerobic treatment (UASB), a chemical -physical stage and a chemical oxidation (Fenton process) step.

Title: SYSTEMS APPROACH TO PROMOTION OF SEWERAGE SLUDGE RECYCLING IN JAPAN**Author /Presenter:** **Rokuta Inaba, Tohru Furuichi, Norio Nishi**
inaba@eng.hokudai.ac.jp**ABSTRACT**

In this study, several recycling systems for sewage sludge in Hokkaido, which is the northernmost part of Japan, were selected as the subject.

Throughout the analysis of problems related to the recycling by systems approach, desirable conditions were suggested in terms of technology and social circumstances based on reports related to the recycling systems and the recycled products.

In conclusion, we refer to a successful case where composts have been made from the sludge from a sewer that has a separated system and low influx of industrial effluent.

The analysis and guarantee by the agricultural sector have resulted in farmers accepting sewage sludge compost.

It is hard to use biogas as it is but other purposes can be considered, such as mixing it with propane gas and its utilization as a raw material for the chemical industry. Responsibility for paying the external costs of fossil fuel consumption has to be institutionalized in terms of the promotion of renewable energy.

Title: COMPARISON OF DIFFERENT HYPOTHESES FOR THE MANAGEMENT OF ALGAE COLLECTED ON SEA SHORE**Author /Presenter:** **Andrea Corti, Lidia Lombardi, Franco Cecchi**
lidia.lombardi@pin.unifi.it**ABSTRACT**

The present work is concerned with the management of algae collected on Tuscany seashore. In particular, two algae end-life treatments, characterised by the energy recovery possibility, were considered: the co-combustion in municipal solid waste-to-energy plants and anaerobic co-digestion with wastewater sludge. Both the processes allow the use of existing plants, within their size limits, in order to treat a material with a production characterised by seasonal trends, for which it is not worth the realisation of devoted plants. The co-combustion has been studied by means of a thermodynamic model, while the co-digestion has been studied by means of pilot plant set up. In particular, in the case of anaerobic co-digestion, the experiments showed that the sludge anaerobic digestion process is able to accept an additional amount of the considered types of algae and biodegrade them, without particular consequences on the process stability. An economic comparison between the two possibilities of end-life treatments has been carried out, considering the additional cost due to the treatment of the added algae with respect to the conventional treatments, showing a higher additional cost in the case of co-combustion with respect to the case of co-digestion.

Title: SEWAGE SLUDGE COMPOSTING IN MURCIA (SPAIN) BY BIOMAX-G TECHNIQUE**Author /Presenter: Hernandez, T, Garcia, C, Moya, J.A. and Carrera, A.****ABSTRACT**

The proper management of urban wastes as sewage sludge is necessary. If it is not done in an acceptable way, it can become a great problem for modern cities. Municipalities can save operating expenses, eliminate problems and increase the convenience of their waste management programs by using their sewage sludge in agriculture and degraded soils. Sewage sludge “recycling” is of particular interest in all Mediterranean countries here soils are constantly lowering their organic matter content, according to the well known “desertification effect”.

However, the direct application of sewage sludge involves the transportation of large quantities of water (typical water content in dehydrated sewage sludge is ranging between 65 and 85%). In addition, bad odors, pathogens, phytotoxic substances, etc., can be a problem when direct application is carried out.

Composting of sewage sludge for soil application allows to overcome these problems. Composting process is a controlled aerobic bio-transformation, which, for instance, implies in the first high degradation rate phase (the so-called thermophilic phase) the sanitation of the fresh organic matter contained in sewage sludge. In this work we illustrate the large scale composting of sewage sludge by a new technique (BIOMAX-G), able to process large quantities of biodegradable materials (up to 1.500 tons per day). This technique has been installed recently in Murcia (Spain) by INUSA-CESPA in the biggest plant for sewage sludge composting in Europe (140.000 tons/year of sewage sludge). As bulking agent, necessary for giving porosity and optimising moisture and C/N, we have used the organic matter (kitchen waste with mixed paper and cardboard) from urban waste of Murcia (this waste is also managed by INUSA-CESPA). Composting process is carried out in three reactor-bays, totally automatic with continuous negative aeration and turning of the biomass by means of three auger-bridge-cranes.

The effective ratio of the sewage sludge with the bulking agent has been optimized. The duration of the high-rate composting process has been established between 16-19 days, and during this time parameters such as temperature, moisture, porosity and degree of stabilisation of the organic matter have been measured in order to optimize the composting process by BIOMAX-G technique.

Title: UPGRADING OF THE PIETRAMELINA COMPOSTING PLANT FOR THE PRODUCTION OF HIGH QUALITY COMPOST

Author /Presenter: F. Valentini*, A. Crispolti, A. Canovai
f.valentini@gesenu.it

ABSTRACT

The composting plant at Pietramelina, in the Municipality of Perugia, Italy, began production in 1988. It was originally set up to treat the organic fraction mechanically separated from unsegregated urban solid waste using Mechanical Biological Treatment (MTB), but has recently undergone a technological upgrading to also treat organic waste from segregate collection for the production of high quality compost, and now uses two completely independent processing lines. Thanks to the technological processes adopted, the total capacity of the plant can be separated with complete flexibility between Mechanical Biological Treatment and quality composting, which has allowed the gradual activation of a system of segregate collection of organic waste in the area served by the plant, without diseconomies or situations of under-utilisation which are typical of the start-up phase of a new plant.

The technological solutions adopted allow the optimum management of the process with a two-fold result. Production of high quality compost from selected materials, mainly for use in organic farming, a high level of stabilisation of the organic fraction obtained from undifferentiated waste, to be used in the management and landscaping of landfill sites and other non-agricultural uses.

This paper describes the most important aspects of the technological adaptation of the plant, as well as the results obtained in terms of the quality of the final products.

Title: ANAEROBIC DIGESTION POTENTIAL OF URBAN ORGANIC WASTE: A CASE STUDY IN MALMÖ

Author /Presenter: Åsa Davidsson, Björn Appelqvist, Christopher Gruvberger, Martin Hallmer, Jes la C. Jansen
asa.davidsson@vateknik.lth.se

ABSTRACT

A study of existing organic waste types in Malmö, Sweden was performed. The purpose was to gather information about organic waste types in the city to be able to estimate the potential for anaerobic treatment in existing digesters at the wastewater treatment plant. Most urban organic waste types found in the study have a significant potential for anaerobic digestion. Some of the waste types were further evaluated by methane potential tests, which gave the methane potential in 30-50 days, and continuous pilot-scale digestion, which was used to simulate full-scale operation. Single-substrate digestion or co-digestion of pre-treated organic waste from source-sorting households (SSOFMSW), sludge from the wastewater treatment plant, sludge from grease removal traps and fruit and vegetable waste was carried out.

The results show that co-digestion of WWTP sludge and the other waste types enhances the methane yield and in some cases even gives synergy effects. Considering single-substrate digestion, SSOFMSW is the only waste in the study which makes up enough quantity to be suitable as base substrate in a full-scale digester separated from the sludge digestion. The two types of SSOFMSW tested in the pilot-scale digestion was operated successfully at mesophilic temperature.

Title: THE BIOMASS COMPOSTING PLANT FOR ORGANIC WASTE FROM SEPARATE COLLECTION AT MACCARESE (ROME): AN EXAMPLE OF THE OPTIMISATION OF TERRITORIAL INTEGRATION

Author /Presenter: A. Canovai, A. Eleuteri, F. Valentini, C. Noto La Diega
secit-ecologica@secit-ecologica.it

ABSTRACT

The plant for the production of high quality compost at Maccarese, planned and built by the Secit company for the AMA – Roma company, was completed at the end of 2001. The plant was built paying particular attention to environmental principles and architectural details, to allow its optimal compatibility with the surrounding area. Around the plant, in fact, there are places of natural beauty which require particular care for the protection of the plants and wild animals in the area, as well as the water sources and the landscape, from any possible pollution. The article contains a description of the plant and the methods put into practice in order to minimise the impact on the environment.

Data relating to the first year of running the plant are also given, from the characterisation of the waste on input to the analyses of the compost produced. Finally, the first results in the field comparing the efficiency of this compost compared to chemical fertilisers are given.

Title: USE OF STABILISED BIOWASTE IN CLAY QUARRY RESTORATION: MONITORING OF ENVIRONMENTAL EFFECTS

Author /Presenter: Paolo Mantovi, Sergio Piccinini, Rosanna Laraia,
Andrea Lanz, Lorella Rossi, p.mantovi@crpa.it

ABSTRACT

The environmental effects resulting from the addition of stabilised biowaste to quarry clay materials, to obtain suitable substrates for quarry restoration, were evaluated in experimental plots with different rates of stabilised biowaste (up to 500 DM t ha⁻¹, mixed to a depth of 115 cm) combined with clay quarry materials. The plots were equipped with tensiometers, ceramic cup samplers and systems for gathering run-off water. The agronomical characteristics of the substrates, along with their vegetation covers, were improved by increasing the stabilised biowaste rate, but the high silt content, together with the high natural sodium content, rendered the substrates nonetheless low-structured and low permeable. As a consequence, water infiltration was very limited, whilst run-off volumes from precipitation were higher. The concentrations of nutrients, organic matter and heavy metals measured in these waters and within the substrates, were below the risk levels prescribed to protect the environment, even for the maximum amount of stabilized biowaste tested.

TITLE: THE INFLUENCE OF THE QUALITY OF THE BIOWASTE ON THE QUALITY OF COMPOST COMING FROM TUSCANY PLANTS

Author /Presenter: Giuseppe Sorace, Chiara Boschi, Francesca Nannini
info@toscanaricicla.it

ABSTRACT

The objective of this experimentation project is to individuate the ties between the separate collection of the compost matrixes, the management of the composting process and the final product quality: Amended Composting of Quality. Particularly we tried to determinate how much the quality of the product in entry can influence the quality of the product in exit through the interpretation of the data of the analyses affected during the experimentations course. We also observed if and how much the used composting process can influence positively the matrixes in entry with lower quality. The experimentation allows to verify and integrate appropriated rules that will give the technical and operative guidelines to obtain a quality compost in the plants of the Tuscany Region. The following data give us the first experimentation results already usable and will be completed to the end of the experimentation in the autumn of this year.

Session: Waste to Energy

Title: AVOIDING HIGH TEMPERATURE BOILER CORROSION BY MEANS OF A BOILER PRISM

Author /Presenter: Bart E.M. Adams, Kris K.E. Peeters, Herman S.W. Diederren, Jac P.F. Wijnhovenbart
adams@segherskeppel.com

ABSTRACT

Cost analyses of Waste-to-Power plants ('WtP') indicate that often more than one third of the maintenance budget is spent on high-temperature boiler corrosion. Based on the understanding of the main corrosion mechanisms, the Seghers Boiler Prism as a primary measure against corrosion is explained. The results of more than 15 years of operational experience are reviewed. From 1997-1999 the Bonn WtP plant (3 x 29MWth, 400°C/40bar) was retrofitted with Prisms. In 2001, a Prism was installed in the WtP of Moerdijk (3 x 81MWth, 400°C/100bar) as an essential part of a revamping program. After more than one year of observation, the remaining two lines were also revamped. The performance of the Prism has been assessed by means of on-line equipment and dedicated measurement campaigns. Additional operational benefits have been quantified. With respect to the Moerdijk WtP, the following effects have been identified:

- A decrease in corrosion rate of the 1st pass boiler roof by more than a factor five.
- An increase in time between shutdowns by a factor 1.5, an 8% increase in throughput.
- A 6% increase in availability, and a strong reduction in ammonia and natural gas consumption.

Based on the above, the pay back period was calculated as 3.1 year.

Title: SER: SECONDARY ENERGY RESERVOIRS**Author /Presenter: Giuseppe Natta****ABSTRACT**

Locally, a region may be characterised by the presence of many Energy Sources. To express the link between these sources and the area that supports them, the concept of Energy Reservoirs is used.

When exploited, some of these Reservoirs are consumed and depleted (e.g. Oil Reservoirs), whilst others are continuously re-supplied and therefore constantly renew themselves (e.g. Hydroelectric Reservoirs).

A common use of these Reservoirs is the production of electricity in power plants; with a yield related to the size of the plant utilised.

For this reason, in the case of hydroelectric power, various catchment areas are often connected to a larger Reservoir to maximise the power supply from the power station.

By analogy with Hydroelectric Reservoirs, which may be called Primary Energy Reservoirs, which can define Secondary Energy Reservoirs (SERs) as being constituted by the Residual Fraction of Municipal Waste (after the source separation), which contains materials with a high-energy content that can be utilised to generate electricity. Like hydraulic catchment basins, these SERs are continuously re-supplied, since Municipal Waste is generated by the constant consumptions of the population of the area.

The Secondary Energy Reservoirs have a very small energy component. It can be shown that the amount of electricity obtainable from an area's Municipal Waste is less than 3 % of the energy it consumes. In addition, putrescible, moist Municipal Waste cannot be transported and stored so as to form larger reservoirs. To solve the problem of optimising the scale of exploitation of the energy of Secondary Energy Reservoirs, Sistema EcoDeco has developed a pre-treatment process for the Residual Fraction which takes place in plants called Intelligent Transfer Stations (ITS).

In these plants a simple bio-drying and stabilisation process is carried out on the Residual Fraction, resulting in a dry, odourless, high-energy content material called AMABILIS. This material, which is transportable and storable, makes it possible to achieve a number of innovative technical solutions for utilisation of the Residual Fraction for energy purposes on an adequate scale.

Downstream of the ITS installations, Sistema EcoDeco has developed two innovative systems that enable the exploitation of the energy contained in AMABILIS in appropriately sized plants: WASTE & POWER system, which uses combustion plants, possibly integrated with Fossil Fuel power plants; NEW, Natural Energy from Waste, which separates AMABILIS into a cellulose-based Renewable Fraction to be used in Activated Bioreactors and a Non-Renewable one, based on non-chlorinated plastic to be used in the WASTE & POWER system or cement kilns. NEW can work on a small scale and can be the first step towards an efficient use of the energy contained in the Residual Fraction. This can be achieved by the progressive integration of an increasing number of ITS.

Title: REMOVAL OF DIOXIN FROM FLUE GASES BY THE ADIOX TECHNOLOGY**Author /Presenter:** Per Lindgren, Sven Andersson, per.lindgren@gmab.se**ABSTRACT**

The new ADIOX technology enables the dioxin (PCDD/F) removal process to take place integrated in traditional wet scrubbers, as tower packing or droplet separators. It provides a simple, cost effective and environmentally friendly solution. A multifunctional scrubber cleaning process based on Adiox can be designed to meet the new EU Directive on emissions to air for dioxin, mercury and acidic components.

As the technology is integrated in well-proven equipment and is of a static nature it will contribute to a very reliable process with high availability.

A further advantage is that the packing, which after several years of operation may be replaced by new material, can be incinerated such that the absorbed dioxins are destroyed. As a result there will be practically no residue product from the dioxin removal process.

The Adiox technology and how it is implemented in some 20 plants in Europe (June 2004) as well as the possibility to integrate extended energy recovery by condensation in the process, basically without any additional equipment of significance, is discussed in this paper.

The use of Adiox may be as a safety filter (police filter), to reduce “memory effect” or to serve as the single dioxin filter downstream of an electrostatic precipitator.

Adiox technology description.

A new construction material is developed, in which carbon particles are dispersed in a polymer, such as PP (polypropylene). In this new material, called Adiox (patent pending), the PCDD/Fs (dioxins) are absorbed in the plastic matrix, diffuse to the surfaces of the carbon particles where they are irreversibly adsorbed. Several types of components can be produced from Adiox to be used in conventional wet gas cleaning scrubbers.

Title: Simulation Model of a pilot scale MSW incinerator**Author /Presenter:** Giovanni Mercurio, Roberta Roberto, Mario Chiadò Rana,
giovanni.mercurio@saluggia.enea.it**ABSTRACT**

The scope of this study is the application of a CFD (Computational Fluid Dynamics) model to simulate the behavior of a pilot scale incinerator that will be installed at ENEA Saluggia Research Centre. A full three-dimensional finite volume model of the incinerator has been developed using the finite-volume code CFX4. The eddy break-up (EBU) combustion model with mono-step chemical reaction schemes was adopted. A synthetic fuel representing the average properties of MSW (Municipal Solid Waste) was considered and different operating conditions were tested. The nature of waste combustion and gas flow phenomena were analyzed within the primary and the secondary combustion chamber. A heat exchanger model was used to simulate the heat released for energy production. Two operating conditions were analyzed: single fuel (MSW) and double fuel or co-firing (MSW and natural gas) combustion. In the CFD simulations, the MSW fuel is modeled as a dispersed phase consisting of solid particles interacting with the gas phase in terms of mass, momentum and heat transfer exchange. The results were evaluated in terms of flow velocities, temperatures, combustion products and particles residence time. The CFD combustion model demonstrated to supply coherent results that provide a valid research tool for future investigations.

Title: FATE OF HEAVY METALS IN SEWAGE SLUDGE INCINERATION BY A FLUIDISED BED AND A ROTARY KILN FURNACE**Author /Presenter:** Braguglia C.M., Marani D., Mininni G.
braguglia@irsa.rm.cnr.it**ABSTRACT**

The main objective of this study was to assess the behaviour of heavy metals during incineration of sewage sludge, alone or spiked with chlorinated hydrocarbons. Experiments were carried out on a pilot incineration plant, including a fluidised bed furnace (FBF) and a rotating kiln furnace (RKF). Chromium, manganese and nickel do not show any tendency to volatilise and to enrich onto the filter ash. Copper shows a significant enrichment only in the RKF tests fed with heavily spiked sludge. On the contrary, cadmium and lead behave as volatile metals in both furnaces. In agreement with the predictions of a thermodynamic model of the combustion chamber, Cd and Pb enrichment increases with increasing chlorine content of the feed. Finally, zinc behaviour is affected by the furnace type, showing refractory properties in FBF tests and, in contrast, significant volatilization in RKF tests. Zinc behaviour is tentatively explained with the hypothesis of locally reducing conditions in the rotating kiln furnace. In conclusion, sludge incineration with fluidised bed furnace presents a lower environmental impact in terms of heavy metals emission with respect to rotary kiln furnace.

Title: USE OF REFUSE DERIVED FUELS AND THE IMPLEMENTATION OF MISSIONS TRADING -POTENTIALS AND ECONOMIC BENEFIT-**Author /Presenter:** Matthias Schirmer, Silke Eckardt, Bernd Bilitewski, Henning Albers, schirm@rcs1.urz.tu-dresden.de**ABSTRACT**

In Germany there are two main concepts for the production of Refuse derived fuels (RDF). These are the biological stabilisation and the mechanical pre-treatment. Depending on the average composition of the RDF, the specific CO₂-emission factors are calculated for the two treatment methods mentioned above. Compared with the standard emission factors of primary fuels [UBA 1998], the emission factors of these RDF are clearly lower. This advantage would very positively affect the total fuel prices, providing an implementation of an emission trade for greenhouse gases and the particulate substitution of primary fuels. The cost of the primary fuel and the emission certificates and the amount of additional payment for RDF, paid to the utilisation plant by the RDF-producer, determine the economic efficiency of an RDF employment. In this paper the correlation between these parameters will be explained. The economic advantages arising from the substitution of primary fuels will be demonstrated by means of calculation examples. It becomes clear, that a possible emission trade can act as an additional incentive for an RDF employment.

Title: NEW ADVANCED TECHNIQUES FOR THE OPERATION OF THE FLUE GAS CLEANING LINES OF WASTE INCINERATORS**Author /Presenter:** Angelo Marcolin, Francesco Zatti, Alessandro Mola
info@areaimpanti.it**ABSTRACT**

Overview of several Area Impianti's plant technologies applied to municipal, hospital, hazardous and industrial waste incinerators.

Technologies comparison: dry treatment lines by double bag filter or by ESP and bag filter, deacidification by sodium bicarbonate, hydrated lime, high specific surface lime, catalytic deNO_x de-dioxins high/low temperature systems or thermal urea deNO_x and dioxin treatment by activated powdered carbon, lignite coke and/or Dioxorb. Gas cooling systems and heat recovery systems. Introduction of new applications concerning the catalyst casing, thermal regeneration of catalyst and a new technique to clean filter bag.

**Title: THE CASE OF ALESSANDRIA: PRODUCTION PLANT FOR RDF
(REFUSE DERIVED FUEL)**

Author /Presenter: C. Noto La Diega , F. Delucchi, C. Proietti
secit-ecologica@secit-ecologica.it

ABSTRACT

In order to reactivate the production line for RDF, which was closed at the end of 1998, the Alessandrino Consortium formed the SOVERI S.r.l company in June 2002 with the aim of:

- Restructuring and managing the existing plant.
- Collecting, at a predetermined cost, the dry waste produced by a screening process by the Consortium.
- Finding a market for the RDF produced.

A public tender was put out in 2001 to select a minority partner with the necessary technical and commercial know-how. The contract was awarded to the SECIT SpA company, a member of the GESENU group, in February 2002. 51% of the SOVERI Srl company is now owned by A.R.AL. S.p.A., and the remaining 49% by SECIT SpA. Reconstruction work on the plant has now been completed (April 2004). Disposal of the fuel has been directed towards combustion plants which currently form a market for this product.

Plant Data:

- Capacity per hour: 15 tons/h.
- Daily capacity: 150 tons/d.
- Daily consumption E.E.: 2,330 kWh/d.
- Investment costs: 900,000 €.

Title: THERMAL TREATMENT OF WASTE FUELS IN CFB BOILERS - LATEST DESIGN AND EXPERIENCE**Author /Presenter:** H. Anderl / E. Offenbacher / T. Ortner
thomas.ortner@aee.co.at**ABSTRACT**

Austrian Energy & Environment AG has been awarded a contract for a new RDF fired 75 MWth (net) CFB boiler whose concept is mainly based on the reference plant RV Lenzing (Austria) which is worldwide the largest CFB boiler for burning RDF and other waste fuels and that holds a world record on operating hours for such applications. Forced by official regulations as well as by the conditions and behaviour of the waste fuels a special design of the boiler has to be applied with following main features:

- Adiabatic furnace in combination with an external heat exchanger.
- Hot gas cyclone combined with an adiabatic post combustion chamber.
- Vertical boiler radiation passes and horizontal tail-end pass.
- Special fuel feeding system and open nozzle grid for fluidisation.

As a consequence the CFB boiler provides an excellent performance including high fuel flexibility, very low emission figures, high efficiency etc.

Title: AN ADVANCED CONTROL METHODOLOGY: HE EXPERIENCE AT AN ITALIAN MSWI PLANT**Author /Presenter:** M. Annunziato, P. Avanzi, I. Bertini, R. Bruschi, S. Pizzuti,
ilaria.bertini@casaccia.enea.it**ABSTRACT**

The extensive use of energy presents a severe challenge to the environment and makes indispensable to focus the research on the maximization of the energy efficiency and minimization of environmental impact (in particular the reduction of NO_x and CO emissions). The proposed idea describes a novel approach, based on *artificial life (ALIFE) environments*, for on-line adaptive optimisation of complex processes for energy production/consumption by means of a *model of performance* of the process itself. Such approach is based on Evolutionary Control methodology that by emulating the mechanism of the biological evolution composes the capability of elaborate models with the continuous learning.

In order to work with MSWI plant it was necessary to improve the stability of the optimiser to obtain a good compromise between stability and reactivity. So a specific MSWI *performance function*, based on fuzzy set theory, has been properly defined in order to characterize quantitatively the current status of the process. Then proper fuzzy sets and the composition criteria have been qualified over experimental data coming from the AGEA plant.

Title: ELECTRIC POWER PLANT FUELLED WITH FUEL (SRF) GASIFICATION PLANT OF MALAGROTTA**Author /Presenter:** **Mauro Zagaroli , Francesco Martino**
maurozagaroli@libero.it**ABSTRACT**

The consortium COLARI, controlled by SORAIN CECCHINI AMBIENTE S.p.A. (SCA), disposes ROME municipal wastes (about 4800 t/d) and works in the waste to energy field from many years, producing in the area of Malagrotta landfill electrical energy from biogas in the 15 MWel power station, equipped with two 5 MWel Gas turbine and nine 1 MWel engines, and biomethane from biogas for automotive use in a plant (based on SCA technology) to feed 22 waste trucks, 8 buses and some company cars.

Last years a new waste anaerobic digester started to treat organics fraction of municipal waste. The capacity of the digester is about 40000 t/y of organic waste and biogas produced in the anaerobic digester is used in electrical power station to produce additional electrical energy. In the second half of 2003 COLARI completed the design of a SRF gasification plant to produce clean gas to burn in a additional CHP unit of electric power station. Solid recovered fuel is produced in two operating Municipal waste mechanical-biological plants built in the same area. COLARI is waiting last final construction and environmental permits for SRF gasification plant and additional CHP unit. Construction start is foreseen at the end of present year. SRF gasification plant has an average capacity of about 500 – 600 ton/day of SRF ad CHP unit nominal electric power of about 30 MW.

The present paper describes the different section of gasification plant (feeding system, gasification reactor, syngas cleaning system) and of CHP unit (gas compressors, gas turbines, heat recovered boilers, De-Nox unit , steam turbine), shows the expected quality of syngas, on the basis of SRF test runs performed in existing industrial gasifiers, the quality of air emissions, both for macro and micro pollutants, and energy efficiency for CHP plant and analyses the environmental impact of plants the measures adopted to limit it.

Title: OPTIMISATION OF RESOURCES AND COSTS FOR THE EMISSION CONTROL OF AN EXISTING MUNICIPAL WASTE INCINERATOR**Author /Presenter:** Friege, Kurt Henning, Hansmann, Gerhard, and Wolfering, Gunther, hfriege@swd-ag.de**ABSTRACT**

The European requirements for emission control of mercury, polychlorinated dioxins and dibenzofuranes, and other micropollutants in the flue gas of a municipal waste incinerator (MWI) mostly are achieved by adsorption techniques using activated coke or combinations of coke and basic reagents to reduce HCl in the same step. Activated coke is an expensive reagent. After use, the contaminated coke has to be disposed. The incineration of used coke, for example in the MWI itself or in a rotary kiln, is state of the art. Combinations of coke and basic reagents cannot be incinerated; normally, they are dumped in geologically sound salt mines. Our experience with an existing MWI equipped with three coke filters and one fabric filter working in parallel lines is presented. The consumption of activated coke in the classical filters is relatively high. The fabric filter working with a mixture of activated coke and sodium hydrogen carbonate has proven to be successful in decreasing the overall adsorbent consumption and costs. Recently, a new adsorption material consisting of coke and calcium hydroxide has been developed for use in the three coke filters. The small scale tests have been proven to be successful. The coke filters presumably will be depleted and refilled with the new adsorption material. The ongoing experiments in one of the filters are reported. As one of the results, the amount of adsorbent used in the filter systems could be reduced significantly. Also, the consumption of energy for operation of the filters decreased. The EU emission targets for organic micropollutants and mercury are met in every combination of filters used at the MWI.

Title: PROCEDURE FOR HEALTH RISK ASSESSMENT FOR AIR EMISSIONS FROM MSW INCINERATION PLANT**Author /Presenter:** F. Cangialosi, G. Intini, L. Liberti, M. Notarnicola, P. Stellacci, g.intini@poliba.it**ABSTRACT**

A procedure for risk assessment analysis for human health concerned with emission of toxic and persistent air pollutants from a Municipal Solid Waste (MSW) incineration plant has been implemented. Using a purposely developed software on the basis of concentrations at ground level for carcinogenic (Polychlorinated Dibenzo-p-Dioxins/Furans (PCDD/Fs) and Cd) and non carcinogenic pollutants (Pb and Hg) and accounting for air inhalation, soil pollution, dermal contact and food ingestion, the procedure permits to estimate exposure pathways for transport and diffusion of contaminants through environmental matrices. The procedure was applied to the MSW incineration plant of Taranto (S.Italy) where risk spatial distribution for each pollutant and human receptor age (children and adults) and cancer excess cases were evaluated and implemented in a Geographical Information System (GIS).

The analysis carried out allowed for assessing global risk in the area investigated as well as for relating cancer excess cases potentially due to the plant to mortality background levels.

Title: ANALYSIS OF THE EMISSIONS OF A WASTE POWER PLANT AND EFFECTS ON THE AIR POLLUTION IN THE SURROUNDING AREA

Author / presenter: Paolo Camiciola , Moreno Onori , Piero Sechi
pcamiciola@libero.it

ABSTRACT

This paper has the object to show the effects of a waste power plant on air pollution in Terni area. In Terni three power plants rise in a limited area in the industrial suburbs of Terni. The ASM Terni S.pa. power plant burns urban waste and produces 2.2 MWe, the other two power plants burn biomass and no dangerous industrial wastes and produce one 10 MWe and the other 4 MWe. The closeness of three power plants was and is the cause of serious worries in the public opinion. The work is based on data from the Emission Monitoring System of ASM Terni S.p.A power plant and on data of air pollution testing stations managed by Terni province. The results show that the emissions of the ASM Terni S.p.A. power plant are clearly lower than the limits laid by laws and that the effect of the power plant on air pollution data is practically negligible and hidden by statistical fluctuations of the data.

Title: RELEASE OF TOXIC TRACE CONTAMINANTS FROM MSW INCINERATION

Author / presenter: S. Cernuschi, M. Giugliano, M. Grosso, E. Palini
stefano.cernuschi@polimi.it

ABSTRACT

The paper reports on global release and mass partitioning in the flux of residues of toxic trace metals and PCCD/F (dioxins and furans), evaluated with dedicated field campaigns at waste to energy installations equipped with furnaces, energy recovery options and flue gas treatment technologies representative of most of the European incinerators in operation at present. Levels of the pollutants of interest were determined in all the solid, liquid and gaseous residues produced by every single facility, and the results analysed in terms of the effects arising from the fed waste and the configuration of the plant. PCDD/F total release between 1.4 and 45 $\mu\text{g}_{\text{TEQ}} \text{ton}^{-1}$ of burned waste was evaluated, with lower values resulting from the adoption of catalytic conversion process for flue gas treatment. Most of the mass flux emitted is associated with solid residues from activated carbon PCCD/F dry control options, with significant contributions also from fly ash produced by particulate removal devices located immediately downstream the boiler and from scrubber blowdowns treatment sludges. For trace metals of interest, releases of 0.4-1.6 g ton^{-1} of waste for Hg, 3-17.6 g ton^{-1} of waste for Cd and 75.5-475 g ton^{-1} of waste for Pb were evaluated, mainly related to the differences in the characteristics of the waste incinerated; flux partitioning results essentially determined by the volatility of each element, with more volatile metals mostly associated with fly ash, dry activated carbon residues and scrubber blowdown treatment sludges.

Title: ALTERNATIVE STRATEGIES FOR ENERGY RECOVERY FROM MUNICIPAL WASTE IN INCINERATORS AND EXISTING INDUSTRIAL PLANTS

Author / presenter: M. Grosso, S. Consonni, M. Giugliano, L. Rigamonti
mario.grosso@polimi.it

ABSTRACT

The paper assesses different strategies for energy recovery from Municipal Solid Waste by dedicated plants and existing industrial facilities. The former include state-of-the-art Waste-To-Energy (WTE) plants generating electricity and heat through a steam cycle, while the latter include the co-combustion of Refuse Derived Fuel in power plants and cement kilns. Scope of the study is the comparison between different possible waste management strategies, based on energetic and environmental evaluations. The preliminary evaluation is based on the data deriving from the first co-incineration trial tests conducted in Italy, and is limited to the comparison of atmospheric emissions at the stack of the plants. Atmospheric emissions deriving from waste combustion (or co-combustion) are compared with avoided emissions released from a fossil fuel-fired steam plant producing the same amount of energy (in the case of dedicated incinerators), or released from the amount of fossil fuel displaced by the waste (in the case of co-combustion). Results show that for dedicated WTE plants, energy recovery (electric and thermal) plays a basic role in the environmental balance, together with the very stringent air emission limits currently in force. For co-combustion of RDF in industrial plants some interesting results are obtained, too; the major concerns are related to the lack of significant experimentation (at least in the Italian framework) and to the long-term monitoring.

Title: CO-INCINERATION OF MUNICIPAL SLUDGE IN AN MSW FURNACE USING PYROMIX PROCESS

Author / presenter : Pierre-Yves Guernion, Magalie Denisan, Delphine Nawawi, Francis Gourtay, André Bréchet, Jean-Yves Doare,
pguernion@cgea.fr

ABSTRACT

The Pyromix system was developed for injecting dewatered sludge in the MSW incineration furnace. Sludge is pulverised on the waste bed, allowing very good mixing and high quality combustion. The feasibility study was done in the Cluses plant operated by Onyx, by injecting sludge for several hours per day for 4 months. This plant is equipped with a counter current and non-water cooled type furnace. The results showed that it is possible to co-incinerate up to 10 % of sludge while burning the same amount of MSW. An improvement of combustion parameters has been observed, corresponding to an increase of steam production.

The fly ash production has been decreased thanks to this system, whereas no major impact has been found on bottom ash production and emission quality. Following these excellent results, an industrial and fully automated unit has been installed in the Briec plant, another EfW unit operated by Onyx, equipped with a similar furnace.

The nozzle design has been improved thanks to CFD modelling. This paper presents results from continuous and industrial operation of the system, performed from February to July 2004.

Title: POWER GENERATION FROM BIOGAS: THE EXPERIENCE ACQUIRED BY MARCOPOLO GROUP IN ITALY

Author / presenter: Luca Brondello, Francesco Ghisoli, Marco Rosso
luca.brondello@marcopolo-e.com
francesco.ghisoli@marcopolo-e.com
marco.rosso@marcopolo-e.com

ABSTRACT

In the frame of the growing interest on resource recovery and energy generation in a sustainable way, the activities aiming at the valorisation of the organic matters, deriving both from agro/zoo technical processes and urban solid waste, play a key role. The use of the generated biogas from the above-mentioned organic matters is since decades the core business of MARCOPOLO ENVIRONMENTAL GROUP (MPE). This paper illustrates the main technologies that MPE utilizes to optimise, from the energetical and environmental viewpoint, the use of the abovementioned sources.

Title: CATALYTIC DECOMPOSITION OF PCDD/Fs ON V2O5-WO3/Al2O3-TiO2 CATALYST

Author / presenter: Grzegorz Wielgosi_ski , Adam Grochowalski (, Tadeusz Machej , Tadeusz Paj_k and W_odzis_aw _wi_kalski
wielgos@wipos.p.lodz.pl

ABSTRACT

PCDDs/Fs formation and emission from waste incineration plant is one of the most important arguments against waste incineration considered by many societies, however, each combustion process may be a significant source of PCDD/Fs to the atmosphere, mostly, when organic materials containing organic chlorine are present in the combustion zone. In the present paper the first investigation on catalytic decomposition of PCDDs/Fs in flue gases from an incineration plant is described. The experiments were carried out on a monolith honeycomb catalyst (V2O5 and WO3 on TiO2/□-Al2O3). The effect of space velocity (in the range from 5000 to 35000 h⁻¹) and temperature (490-580 K) on catalytic oxidation and dechlorination rate was examined. Analysis of PCDDs/Fs in gas stream was done using EN- 1948 method. The investigation was carried out in a semi-technical catalytic plant which has been coupled on-line to a real hazardous waste incineration plant, where industrial and hospital wastes are destroyed.

Title: The Low Temperature Shell Denox System for Removal of NO_x and Dioxins from Waste Incineration Flue Gas

Author / presenter: Dr. Onno L. Maaskant, Dr.S.Cavalli, onno_maaskant@cricatalyst.com
stefano.s.cavalli@virgilio.it

ABSTRACT

As a result of increasingly stringent limits on NO_x and dioxin emissions from incinerators and other combustion devices, operators need more demanding requirements from flue gas cleaning systems. Environmental agencies are requiring more detailed information on the fate of the dioxins and any related pollutants that have been removed. Particularly for the waste incineration industry it is of great operational interest that the Shell System not only removes NO_x but that it is also capable of removing dioxins. In order to investigate this further we have carried out a program of basic research into how to destroy dioxins, followed by actual operational proof that the system works in practice. Furthermore, savings are obtained as no or minimal flue gas reheat is necessary. In many cases the simultaneous removal of NO_x and dioxins is obtained with one single Shell System.

Title: HOW TO DETERMINE THE LOWER CALORIFIC POWER WHEN OPERATING A MUNICIPAL SOLID WASTE (MSW) INCINERATOR PLANT IN VENICE. COMPARING METHODS.

Author / presenter: Ing. Pietro Paoli – ing. Angelo Bovo, ing.
Alessandro Pescatori – Dott. Sergio Brandani, a.bovo@vestaspa.net

ABSTRACT

In Venice municipality about 30% of the solid urban waste produced, is eliminated in an incinerator thereby producing electric energy. Due to seasonal factors and to the amount of tourists in the city, both the quantity and quality of the waste brought to the plant varies. The lower calorific power of the MSW can especially be subject to variation which consequently influences the plant performance. The plant has been designed so that its maximum thermo-power potential is the product of the waste weight flow and its lower calorific power (LCP). It's useful to be aware of the LCP because of the factors that can alter waste characteristics, such as humidity caused by weather conditions, the amount of tourists in the city and the presence of grass or other vegetable organic material. It is rather complicated to determine the LCP on the basis of waste-composition analysis as the preparation of waste samples for laboratory analysis is very time consuming. This method allows to determine the LCP in a fast and accurate way, using the process data registered in the everyday management of the plant, thus guaranteeing control over the variables of the process and allowing to monitor the economical balance within a compatible time-limit.

Title: TECHNICAL AND ENVIRONMENTAL OPTIMIZATION OF WASTE-TO-ENERGY PLANTS VIA PAN-EUROPEAN COLLABORATION**Author / presenter: Christopher P. Hunter, David J. Baxter, Richard J. Fordham,**
Christopher.hunter@irc.nl**ABSTRACT**

More than ever there is an accepted need to encourage and further develop sustainable energy systems. Existing and new MSW incineration plants are encouraged or required to harness the maximum amount of energy from the process. There are efficiency targets that must be met. There is also European Union legislation and consultative procedures defining the conditions that must or should be met when operating waste-to-energy plants. The structure and activities of the pan-European PREWIN (Performance, Reliability and Emission reductions in Waste INCinerators) Network are described. Currently, the Network comprises three Task Groups addressing issues related to material performance, plant maintenance and repair, and emissions. The different Task Groups are made up of members who have expertise in the subjects addressed. The result of the work is mainly technical documents and procedures and examples of these are reported. In a short period since its inception, the Network has already proved its value to the important actors in the waste-to-energy sector and is contributing to developments in the industry that will significantly assist in the achievement of relevant EU and international targets.

Title: DEVELOPMENT OF THE ADVANCED WASTE INCINERATOR –MASS-BURN RENAISSANCE–**Author / presenter: Jin AKIYAMA, Shizuo KATAOKA, Ryoji SAMESHIMA**
akiyama@takuma.co.jp**ABSTRACT**

We have been developing an advanced stoker-type waste incinerator aimed at reducing the generation of toxic materials during combustion, and maximizing the heat recovery from the waste incineration as a source of energy. In the combustion technologies, we have developed a burnout gas re-circulating system that mixes and stirs primary combustion gas and uses primary air effectively, and an advanced fuzzy control to accommodate the variances of waste condition. In 2001, these combustion technologies were put to a demonstration test at an 85- ton/day MSW incineration plant for about six months at a reduced excess-air ratio of 1.3, the same level for solid fuels. The volume of exhaust gas was reduced by 20% compared with the regular methods, improving thermal efficiency of waste heat boiler by 3%. The CO average concentration was 1ppm or less without 10ppm of its peak, and the NO_x concentration was reduced by 30~40%. The dioxins concentration in the exhaust gas became less than 0.001ng- TEQ/m³ N, one-tenth of the regular system, and the dioxins total emission was reduced by nearly one-half.

**Title: ENVIRONMENT PROTECTION AND ENERGY EFFICIENCY IN
WASTE TO ENERGY: THE BRESCIA EXPERIENCE**

Author / presenter: Antonio Bonomo, abonomo@asm.brescia.it

ABSTRACT

On March 1998, two and a half years after the beginning of construction, the Waste to Energy plant of the city of Brescia (2 x 33 ton/h of waste in the original configuration; 3 x 33 t/h since March 2004) started his operation.

In 2003, 552,000 tons (L.H.V. 8.37 MJ/kg) of waste (including 121,000 of biomass) were processed, while producing 361 GWh of electricity and 290 GWh of heat for the district heating network of Brescia, which serves a population of more than 130,000. The plant (the greatest in Italy) processes all the non recyclable Municipal Solid Waste (MSW) generated in the province of Brescia (population of more than 1 million) and provides the city of Brescia (200,000 inhabitants) with one third of its electricity and heat demand.

No MSW are any longer landfilled in the province of Brescia. The WTE plant of Brescia is part of the “sustainable development” strategy of the City and also of the “Brescia Integrated Waste Management System” (BIWMS), which has been implemented by the City Council since 1992, with a great involvement of citizens. The aim of BIWMS is the maximum recovery of materials (from separate collection of recyclable waste; in 2003, 40% of MSW were recycled and a new goal of 50% was defined) and energy (from the remaining waste). Much attention has been paid to the protection of the environment and to the efficiency of the energy generation which amounts to 27% as electricity, 55% as heat, and 82% overall (based on the L.H.V. of the waste).

As a result, on the bases of electricity and heat generated, the emissions to air are lower than those produced by coal, oil, and gas fueled power plants. In year 2003, the equivalent savings in fossil fuels are 120,000 tons of oil and emissions of more than 300,000 tons of CO₂ were avoided, compared with landfill disposal of waste and energy generation with fossil fuels. One of the innovations of the Brescia plant is the recirculation of flue gas that results in higher oxygen utilization and lower process gas volume per ton of MSW processed. Six years of operation experience with progressive improvements, have shown that, within the BIWMS, it is possible to increase the recovery of MSW and to produce cleaner energy, giving a concrete contribution to the sustainable development in a typical densely populated urban area.

Title: Energy Recovery from MSW through Production of High Quality Solid Recovered Fuel (CDR-P)**Author / presenter: M. Frigerio, C. Zanotta, L. Zucchelli****ABSTRACT**

In the management of Municipal Solid Wastes (MSW), after collection of recyclable components, residual fractions remain to be treated and recovered.

The standard process used to treat and recover the MSW residuals (MSWR) is the temperature combustion in waste incinerators with energy recovery from the flue gases. These plants are very capital intensive, mainly due to investments for the emissions treatment section, and very often the building of a new plant is not accepted by the local community because of the perception of environmental risks. The research here presented examines the possibility to convert MSWR to a standard, regular fuel (CDR-P, to be used as co-fuel with coal) through a low environmental impact process. This could open the possibility of using existing, thermal plants (like coal fired power plants, cement kilns) to recover the energy content of MSWR.

A demonstration plant has been built in West Italy (Cuneo) during second half of 2002 and is fully operating from the January 2003.

Title: SAMPLING OF SOLID RECOVERED FUELS (SRF) FOR QUALITY ASSURANCE IN COINCINERATION - LESSONS LEARNED FROM THE APPLICATION OF CEN TC 292 DRAFTS**Author / presenter: Michael Prochaska, Michael Schelch, Claudia Hofer, Georg Raber, Karl E. Lorber**
Michael.Prochaska@unileoben.ac.at**ABSTRACT**

The results of two solid recovered fuels (SRFs) sampling projects are presented. In project No.1, inter-laboratory trials with 3 SRFs were carried out: sludge from de-inking recycled paper, mixed plastics from household collection and a synthetic SRF. Project No.2 investigated on-site sampling and splitting protocols involving 4 plants in Austria. Through a high number of samples expected fundamental errors and actual standard deviations were compared for the parameters calorific value, loss on ignition, Cl, Cu and Cd, including different sample preparation options. Both projects followed the probabilistic sampling methodology of CEN TC 292 WG 1-5 drafts (2001) with slight adoptions. Comparisons to current drafts (prEN 14899 and CEN TC 343) are made. Used as splitting method, fractional shovelling introduces less uncertainty than coning and quartering in on-site sample reduction for SRFs. The inter-laboratory trials showed acceptable recovery rates including calorific value, loss on ignition, Cl, Hg and Zn for the synthetic SRF except for Cd. Increased laboratory effort resulted in more precision, but correctness was not improved. The probabilistic model provided good estimations for the sampling error related to the chlorine content. For heavy metals, the probabilistic model does not fit, as pre-requirements for the application of the model (e.g. normality of the values) are not fulfilled.

Title: DESIGN OPTIMISATION OF SEWAGE SLUDGE DRYING AND INCINERATION**Author / presenter: Giuseppe Mininni, Maria Concetta Tomei and Camilla M. Braguglia,**
mininni@irsa.rm.cnr.it**ABSTRACT**

An integrated process where sludge is dried before incineration is presented and discussed. Drying is carried out by utilizing saturated steam at medium pressure (1.22 MPa and 188 °C) produced in a boiler downstream the incineration furnace. The study evidenced that size of different units (dryer, fluidised bed furnace, boiler and units for exhaust gas treatment) can be significantly reduced, by recovering heat from the exhaust gas, just in such amount needed for drying the sludge up to a cake concentration allowing autogenous combustion in the furnace. When the recoverable heat is not enough to dry the sludge at the required autogenous concentration, auxiliary fuel is required and the feed cake concentration is reduced. According to this approach, sludge incineration has to be basically considered a disposal operation according to European Directive 91/156, as electric energy recovery could be convenient only when cake concentration after dewatering (before drying) is very high, with values hardly reached by conventional mechanical dewatering units.

Session: Sanitary Landfill and Site Remediation**Title: GASEOUS EMISSIONS FROM LONG-TERM EXPERIMENTS IN DEPENDENCE ON MECHANICAL-BIOLOGICAL PRE-TREATMENT****Author /Presenter: Anke Bockreis, Iris Steinberg,**
a.bockreis@iwar.tu-darmstadt.de**ABSTRACT**

In order to minimise emissions and environmental impacts only pre-treated waste should be landfilled. The aim of the project is the investigation of the gas-formation of mechanically biologically pre-treated waste in comparison to non pre-treated waste as well as thermally treated waste in long-term experiments. The focus of the paper is on the gas formation and especially the cumulated gas volumes and the composition of the gases. The main influencing factors on the gas-formation which are the water content and the temperature of the deposited material are presented. Furthermore the results of the measured cumulated gas volumes are compared with the calculated gas volumes based on a theoretical model. In this context also the measured compositions of the produced gases are discussed in a view of a theoretical approach of the gas formation phases.

Title: SIMULATION AND ANALYSIS OF LANDFILL GAS FUELLED MICROCOGENERATION SYSTEMS**Author /Presenter:** **Elio Jannelli, Mariagiovanna Minutillo, Enzo Galloni**
jannelli@unicas.it, minutillo@unicas.it, galloni@unicas.it**ABSTRACT**

The goal of this work is to evaluate best operating of microcogeneration systems for recovering energy from medium size landfills.

The landfill gas production is a complicated process involving many variables (gas composition, heat value, etc.) so that an estimation of energy recovery is difficult; furthermore the biogas production is variable in the time.

First a prevision model has been used to estimate biogas production and to calculate energy recovery during landfill life (in each year in which the landfill is opened).

The biogas produced by anaerobic decomposition of refuses contains approximately 50% methane, so it can be used in different power systems. In Italy it is usually burnt into gas engine, because of medium landfill size that does not allow to produce electric power higher than 1 MW.

A new possibility in the field of low power technology (<1 MW) is represented by micro turbine.

In the present work the performances both of gas engines and microturbines plants have been studied. The possibility to recovery heat has been evaluated too.

Performances have been calculated, at full and partial loads operation. A thermodynamic simulation program has been used to reproduce all operating points.

An economic analysis has been carried out considering installing and management costs, revenues and at the end the net cash flow has been estimated.

Title: THE USE OF VOLCANIC SOIL AS A SANITARY LANDFILL LINER AND ITS CAPACITY TO RETAIN SOME SPECIFIC HEAVY METALS

Author /Presenter: **Rodrigo J. Navia , Barbara S. Fuentes, Alberto I. Bezama, Karl E. Lorber, María C. Diez**
rnavia@ufro.cl; rodrigo.navia@stud.unileoben.ac.at

ABSTRACT

The capacity of the volcanic soil of Southern Chile to adsorb some specific heavy metals commonly present in landfill leachates was determined at pH 4.5 and 7.5 and for three different soil depths. The heavy metal cations Cu^{2+} , Zn^{2+} adsorb more in the volcanic soil at pH 7.5 while for Pb^{2+} no significant difference was encountered. On the opposite, the CrO_4^{2-} anion adsorbs more at pH 4.5. As the pH at the zero point charge of the natural volcanic soil is 5.5 it is clearly stated that at pH values lower than 5.5 the soil surface would be positively charged and anions would adsorb preferentially. On the other hand, at pH values higher than 5.5, the soil would be negatively charged, making cations to adsorb strongly. The maximum heavy metals uptake onto volcanic soil was determined to be 2.74 mg/g for Cr^{6+} as CrO_4^{2-} , 5.32 mg/g for Cu^{2+} , 5.86 mg/g for Zn^{2+} and 7.44 mg/g for Pb^{2+} . These results suggest that the volcanic soil of Southern Chile is comparable, as a natural adsorption material, to zeolites and natural landfill clay liners.

Title: UTILIZATION FOR ENERGY PURPOSES OF A BIOGAS PLANT IN MEDOLLA LANDFILL

Author /Presenter: **Roberto Zocchi, Maurizio Bragaglia**
maurizio.bragaglia@aimag.it

ABSTRACT

The plant of biogas utilization for energy purposes in operation in Medolla landfill since April 2003 was designed to generate altogether 1,098 kW gross electric power. The suction system, presently consisting of 53 biogas wells, is divided into three functional sectors corresponding to as many waste disposal cells, all closed in three different periods. The utilization of the plant for energy purposes consented to generate in total about 4,000 MWh electric power in the course of nine months. All the energy produced was sent to the network while ensuring, in the meanwhile, an effective disposal of about 8,000t biogas generated by the landfill with a time service factor exceeding 95%.

In particular, about 250,000 t urban and special waste assimilable to urban waste were stacked from December 2000 to February 2003 in the last cell, now definitely closed, of an approximately volume of 300,000 m³, consisting of 18 suction wells and a biogas regulation unit. The actual flow of biogas harnessed from the landfill last cell was 450 Nm³/h.

Such a remarkable difference can be explained on the grounds of the following:

- Excellent clay waterproofing of the landfill.
- Mechanical pre-treatment of waste.
- Biological pre-treatment of waste.

Title: TECHNICAL-ECONOMICAL ASPECT ABOUT BIOGAS PRODUCTION OF MARIANA MANTOVANA LANDFILL (ITALY)

Author /Presenter: Simone Trazzi, Maurizio Bevilacqua,
Marco Bergonzoni, Massimo Bertolini
airtraces@libero.it

ABSTRACT

This article deals with the analytic rating of the economic investment in an energy recovery plant of a dump, in relation to the estimate of its capability to extract the biogas producing, its transformation, its sale and the Green Certificates. The presented approach, applied to the discarica di Mariana Mantovana (MN), consists in the esteem of potential sceneries of biogas flare coming from its production forecasts, according to different models: the LandGEM Model by U.S. EPA and stochiometric model describing the degradation of the organic fraction. These sceneries allowed to estimate the annual quantity of electrical energy, which could be produced by engines installed in the landfill. Then, the analysis of the investment for the installation of the recovering energy plant developed. The obtained results show an increase of the biogas flare during the whole 2005 (forecasts reveal that the max. value of biogas extraction could be more than 2.000.000 Nm³). However, a decreasing trend is expected to develop in the coming 20 years. The electric energy production estimated in the space of 16 years results more than 3.500.000 kWh/year. The economic assessments have recorded positive trends pointing out the advantages of this investment.

Title: FINANCIAL PROVISIONING FOR LANDFILLS: AN INTERNATIONAL OVERVIEW

Author /Presenter: Nick Cawthorne , Francesco Belfiore , Roger Parker,
Michael Snow, Mark Roth. ncawthorne@golder.com

ABSTRACT

A Financial Provision is a financial security put in place by the operator of a landfill to ensure that obligations under the permit or licence can be discharged, particularly closure and aftercare obligations, even in the event that the operator ceases trading. The Financial Provision is taken out in the form of a bond, third party guarantee or some other financially secure arrangement with the beneficiary usually being the regulatory authority.

The authors of this paper have pooled their combined international knowledge of this activity in the regulatory jurisdictions of England/Wales, Italy, Victoria Australia, Ontario Canada and the USA.

The current situation with respect to financial provisions in each area is described and contrasted. The paper identifies that the current extent of financial provision cover is very limited outside the USA and that the financial instruments used vary within countries as well as between countries and that not all of these may be appropriate. It is recommended that public sector landfills should maintain full financial provisions; that the evaluation of the closure and aftercare liability is determined from a detailed site specific cost assessment and that environmental contingency element should typically be relatively small and evaluated simplistically. Cash based provisions to cover closure and aftercare may more directly address the requirements, including the issue of sustainability.

Title: RENATURALIZATION OF A CONTROLLED LANDFILL USING INERT EXCAVATION SOIL AND MUNICIPAL WASTE COMPOST**Author /Presenter: Mario Businelli, Rolando Calandra, Giovanni Gigliotti, Daniela Businelli, Federico Valentini, mbusinel@unipg.it****ABSTRACT**

The research studies the transformation kinetics of a landfill covering anthropomorphic soil obtained from an excavation soil mixed with a mechanically-separated municipal waste compost (MWC). The experiment was conducted in a landfill (Pietramelina, Italy) managed by Gesenu SpA. The disposal of waste by burial in the landfill was done in horizontal layers, each having an external front that represents the disposal of ten years starting from 1993. The research was done in the 1993, 1994, 1997 and 2001 disposals. After having done a survey of the soil profiles, many soil samples were collected and subjected to a series of physical, chemical and biochemical analyses. The results obtained suggest that in ten years the upper layer has gained a pedological structure (subangular blocky and/or crumby) originating an A horizon. The total extracted C shows an increase of the humic substances content as evidenced by the humification parameters. The enzymatic activity tested on the A horizon are not indicative of the soil evolution whilst those in the C1 horizon seems to be valid indicators for monitoring the evolution of the anthropogenic soils made using MWC.

Title: RECLAMATION OF A POLLUTED SITE IN SENSITIVE AREAS**Author /Presenter: Rocco Pandolfo, Salvatore Masi, Ignazio M. Mancini, Francesco Russo, rpandolfo@unibas.it****ASTRACT**

The present work aims at characterizing faster analysis methods to reorganize a small contaminated site located near a sensitive area.

The system proposed aims at removing the economic limits imposed by the current analysis methods and at characterizing suichart indications on the landfills' stabilization degree and on their residual risk.

The site we examined is the urban solid waste landfill used in the 90s by the town of *Calvello (Potenza – Italy)*; it is located near a stream which is a tributary of the dam of Camastra, a drinkable water reservoir, in an area named “Isca del Gallo”. There, the waste bestowal was carried out without either control or any jam intervention or intermediate covering. Only recently the waste has been covered by a layer of partially permeable land with variable thickness. From a strictly geological point of view, the site is composed of melted materials coming from fluvial deposits and its substrate is characterized by the presence of a structurally complex land with high clay contents. The work we carried out gave indications which can be useful as terms of comparison for other similar situations.

Title: PERFORMANCE BASED SANITARY LANDFILL ESIGN USING GEOGRAPHIC INFORMATION SYTEMS INTERFACED WITH SYSTEM SIMULATION MODELS

Author /Presenter: Ba_ak Tarhan, Kahraman Ünlü, kunlu@metu.edu.tr

ABSTRACT

The solid waste management problem is one of the important environmental issues that most cities face in the world. Limited availability of funds and high landfill investment costs are the major obstacles to the solution of the problem. Also, the difficulties faced are partially stemming from the strict design requirements of the regulations. The main objective of this paper is, by interfacing the Geographic Information Systems (GIS) with System Simulation Models (SSM), to develop a methodology and tools that can enable the determination of landfill design components providing the desired performance with minimal design details. In this paper, the conceptual framework of the methodology being developed and some example applications of the methodology demonstrating the selection of landfill design components that are suitable for the existing site conditions are presented. The conceptual model defines design variables, performance criteria and design components of a landfill. ArcMAP GIS software, Visual HELP and VADSAT SSM are used to handle the site specific data and to evaluate the landfill performance, respectively. Results indicate that the landfills having the same design properties show different performance under different site conditions; therefore, a landfill design that is technically and economically feasible should be selected on the basis of performance.

Title: VALUATION OF TECHNICAL STRATEGIES FOR LANDFILL ODOUR IMPACT REDUCTION USING DYNAMIC OLFACTOMETRY

Author /Presenter: Selena Sironi, Laura Capelli, Massimiliano Il Grande, Marco Bergonzoni, selena.sironi@polimi.it

ABSTRACT

This work led to the experimental determination of the odour emission rates associated to the principal odour sources in landfills and the relative importance of each odour source on the total odour impact of the landfill, in order to value the efficiency of the different odour control strategies that can be adopted for the minimization of its environmental impact. In order to determine the average odour emission rates, the odour concentration values associated to the odour sources in nine different landfills were measured using dynamic olfactometry. Furthermore some olfactometric analysis were conducted with the purpose of assessing the odour abatement efficiency of some traditional landfill management procedures and operational practices (waste capping, ordinary maintenance, etc.) and alternative odour control systems (special odour abating sheets, deodorizing products, etc.). Besides, the valuation of the odour emission rate of every single odour source enabled to estimate the total odour impact of a landfill, considering two very different real examples.

TITLE: CHALLENGES OF DESIGNING A VERTICAL LANDFILL EXPANSION OVER EXTREMELY COMPRESSIBLE SOILS

Author /Presenter: R. David Espinoza, Ph.D, Anne M. Germain, P.E., DEE, N.C. Vasuki, P.E., DEE and Michael F. Houlihan, P.E., DEE, despinoza@geosyntec.com

ABSTRACT

Because the Cherry Island Landfill (CIL) was built over an area used for many years as a dredge disposal site, the foundation of the entire landfill consisted of a low permeability, highly compressible, and very soft dredge deposit. Based on current airspace consumption, the estimated remaining capacity is approximately six years. To increase capacity at the CIL site, a vertical expansion was designed. The vertical expansion required the foundation be improved such that an adequate factor of safety against overall slope stability was obtained. The selected foundation improvement consisted of installing prefabricated vertical drains (PVDs) as well as a mechanically stabilized earth (MSE) wall around the landfill perimeter. Because large settlement were expected to take place under the proposed perimeter MSE berm and under the landfill, special design considerations for the leachate collection and transmission system, stormwater management system, and landfill gas (LFG) system were taken into account. This paper describes the challenges of designing a landfill expansion over this type of foundation soils.

Pending approval of the proposed design submitted to Delaware's Department of Natural Resources, construction is anticipated to begin in the summer of 2005. The selected foundation improvement will allow the landfill to be expanded to an elevation of 59.4 m-mean sea level (msl) (195 ft-msl), gaining an additional 20 million cubic meter of waste capacity.

Title: THERMAL RECOVERY FROM LANDFILL BIOGAS AFTER ENERGY EXPLOITING

Author /Presenter: Fulvia Chiampo , Ivano Conte , Enzo Genco
fulvia.chiampo@polito.it

ABSTRACT

Biogas generated in a Municipal Solid Wastes landfill is collected and, when economically advantageous, it is exploited in internal combustion engines to produce electric energy, also taking into account that at present, excellent transformation efficiencies are achievable, precisely 38-40 % of the biogas thermal content. The flue gas deriving from combustion is at about 500 °C, in other terms it has still a valuable enthalpic content. In addition, the engines need lubrication and refrigeration loops, and intercooler devices to cool down the compressed gas mixture before entering the engines themselves. In this frame, thermal recovery is possible by modular heat exchangers: they produce hot water, cooling down respectively oil, water and gas. Moreover, the flue gas can be cooled from 500 °C to 180 °C. In this paper, the Municipal landfill of Torino, Northern Italy, has been considered for a study on thermal recovery from biogas after its energy exploitation.

The considered recovery operations are:

- District heating.
- Absorption chilling.
- Sludge drying.
- Superheated steam production.

Different scenarios are possible, according seasonability, thermal level and quantities of recovery.

Title: GAS COLLECTION EFFICIENCY IN A MUNICIPAL SOLID WASTE LANDFILL. A CASE STUDY.

Author /Presenter: Arthur Alexanian ,Gianluca Sacchi and Enrico Davoli,
info@idroconsult.it

ABSTRACT

In this study a flux chamber has been designed, realised and used to monitor surface landfill gas (LFG) emissions in a large municipal solid waste (MSW) refuse disposal. Sampling has been performed in 40 different points, representative of new and old lots, both in flat sites and in slopes of the landfill. These points were chosen based on a 50 x 50m square grid to cover a total effective landfill surface of 130,000 m². The flux chamber was designed as recommended by U.S. EPA, with minor modifications, and consists of an isolated flux chamber with a controlled flow of pure inert gas. It was constructed in polycarbonate, supplied with a source of zero grade air with a controlled rate between 40-50 l/min.

The surface enclosed area by the flux chamber was 1,0 m². Samples were collected at the flux chamber exhaust manifold and analysed directly using a portable GC/FID instrument detecting methane. Methane concentration has been used to calculate the methane specific emission rate (SER), while LFG SER have been estimated by direct comparison with LFG methane concentration of the closest extraction well or header port. Total LFG collection efficiency (CE) has been calculated, assuming zero subsurface emissions, by comparing total LFG release (surface emissions, expressed as m³/h, and collected flux) and surface emissions flux giving an overall collection efficiency of 75% and 71% in two different studies.

Title: ROLE OF COUPLING NUMERICAL SIMULATION AND RESISTIVITY METHOD IN THE INTEGRATED MANAGEMENT SYSTEM FOR CONTAMINATED SITE REMEDIATION

Author / presenter: Kazuei Ishii* and Tohru Furuichi,
k-ishii@eng.hokudai.ac.jp

ABSTRACT

In this study, the idea of the data model was used to develop an Integrated Management System for Contaminated Site Remediation (IMS-CSR). A data model is a method of relating and systematizing elements of complex phenomena from the viewpoint of data flow between the elements. It provides standardized procedures from an overall standpoint. First, an overall data model was developed to provide a procedure from an initial investigation to proposal of alternatives. In particular, a detailed data model for prediction of contaminant distribution in groundwater using numerical simulation was developed as a part of the overall data model and was applied to a real contaminated site. In addition, the resistivity method, which can provide 2-D or 3-D information and is different from discrete information such as boring data, was also applied and compared with the contaminant distribution calculated by numerical simulation. As a result, the detailed data model provided reliable procedures to predict rationally the contaminant distribution in groundwater based on the observational data. There was good agreement between the contaminant distribution calculated by numerical simulation and the apparent resistivity distribution with regard to the shape of contaminant distribution. This fact suggested that the contaminant distribution could be predicted more accurately. Consequently, coupling numerical simulation and the resistivity method could play a role to increase the accuracy of the prediction.

Title: USING HONEY BEES AS MONITORS OF AROMATIC HYDROCARBON POLLUTANTS IN RIO RIAZZONE WASTE-LANDFILL (REGGIO EMILIA, ITALY)

Author / presenter: Vittorio Nizzoli , Ilaria Negri, Marco Pellecchia,
Lorenzo Pizzetti, Tania Tellini

ABSTRACT

Honey bees (*Apis mellifera*, Linnaeus) are considered bioindicators of chemical pollutants present in the environment and bees products, such as honey, are used as bioaccumulators of heavy metals, radionuclides and pesticides. The aim of this research is to evaluate if an hypothetical gas leakage from the gas collection system can affect honeybees colonies located on the Rio Riazzone waste-landfill final covers in course of restoration, causing a concentration of the organic pollutants in bees lipophilic products like wax. Qualitative gaschromatographic analysis performed on waxes produced in the hives located on the fully exploited landfills didn't show any presence of volatile organic compounds (VOCs).

Nevertheless, insects mortality rate exceeded the threshold level, suggesting the presence of an abnormal environmental situation, which may have disturbed honey bees.

The absence of VOCs in waxes could indicate a too low exposure time (about three weeks) of the hives, as it has been demonstrated in a previous research, where bees waxes have been exposed for about four months, absorbing organic compounds originated by the MSW landfill itself and by vehicular traffic of lorries for waste transport.

Title: EX SITU SOLID-PHASE BIOREMEDIATION WITH COMPOST ADDITION FROM MSW: PRELIMINARY PILOT SCALE EXPERIMENTAL RESULTS ON DIESEL-CONTAMINATED SOILS

Author / presenter: Maurizio Ciani, Filippo Mangani, Fabio Tatàno, Federico Valentini, Alessandro Canovai
fata@uniurb.it

ABSTRACT

Compost addition from MSW can be a possible, interesting enhancing method for bioremediation of hydrocarbon contaminated soil. In order to investigate this integrated treatment option, a solid-phase (fixed-bed) reactor was developed at pilot-scale, and preliminary treatment tests were carried out with 1% (w/w) diesel-oil contaminated soil (silty sand). Three conditions were compared: no compost, 30% and 15% w/w MSW compost. Bioreactor with 15% compost showed the best performance, in terms of total petroleum hydrocarbon removal and biomass presence, consistence and temporal evolution.

Title: TREATMENT OF LEAD AND CADMIUM CONTAMINATED SOILS: A COMPARATIVE STUDY ABOUT SOLIDIFICATION/ STABILISATION, CHEMICAL EXTRACTION AND PHYTOEXTRACTION PROCESSES

Author / presenter: Carlo Collivignarelli, Mentore Vaccari
mentore.vaccari@unibs.it

ABSTRACT

General approaches to remediation of metals contamination include isolation, immobilization, toxicity reduction, physical separation and extraction. These general approaches can be used for many types of contaminants but the specific technology selected for treatment of metals contaminated site depends on the form of the contamination and other site-specific characteristics. This paper takes in consideration the case of cadmium and lead contaminated soils. In particular, the aim is to compare two innovative processes (chemical extraction and phytoextraction) with the conventional solidification/stabilisation technique.

The results show that, with respect to the solidification/stabilisation process, phytoextraction, even if improved by means of chelating agents, is cheaper but requires excessive remediation time, whereas chemical extraction is very effective and would become economically favourable if the extracting solution was recirculated.

Title: PCB-CONTAMINATED SOILS: COMPARISON BETWEEN DIFFERENT OXIDANTS**Author / presenter: Renato Baciocchi, Renato Gavasci, Francesco Lombardi**
gavasci@ing.uniroma2.it**ABSTRACT**

Advanced oxidation processes (AOPs) have become one of the most interesting and promising remediation techniques. Their operational principle is based on the idea of generating a pool of oxidizing species in the subsurface environment. The different AOP processes differ simply in the way this pool is produced. In this work, the performance of two AOPs based on Fenton's reagent and Sodium Persulfate for the treatment of a PCB contaminated soil (47 mg/kg dry soil) have been tested and compared.

The most effective oxidant for the treatment of a PCB contaminated soil was shown to be sodium persulfate, whereas Fenton's reagent was almost ineffective. This may be due to the intrinsic low stability of hydrogen peroxide, that was enhanced in this case by the properties of the contaminated matrix, such as high content of organic carbon and mineral oxides. Thermal effects due to the exothermic character of hydrogen peroxide decomposition reactions may have also played an important role.

Title: A NOVEL APPROACH FOR THE REDEVELOPMENT OF OLD LANDFILL SITES**Author / presenter: Karl E. Lorber, Alberto Bezama, Johannes Novak, Rodrigo Navia , Werner Erhart-Schippek**
iae@unileoben.ac.at**ABSTRACT**

The Köglerweg sanitary landfill (in Graz, Austria) was operated between the years 1963 and 1985. During this period, the landfill received about 9.5 million m³ of solid wastes from the city of Graz as well as industrial wastes coming from the near Styrian region. The landfill site in Köglerweg was provided neither with basis sealing nor with an appropriate surface sealing, so the leachates percolated unhindered into groundwaters that fed the drinking water sources of the Styrian region. In order to eliminate this danger, the city of Graz constructed a 1.1-km long cut-off wall, and installed a groundwater pumping and treating station for the sinking of the groundwater table in the precinct, thus preventing the further contamination of groundwaters. additionally an active landfill degassing plant has been operated since the mid 70's at the Köglerweg landfill to prevent gas migrations.

An international Building company acquired in 1996 a 50,000-m² section of the site for redevelopment, with the objective of constructing its main administrative offices for the Styrian region. This work intends to present the innovative actions involved in the redevelopment project conducted at the Köglerweg site.

Title: WETLAND TREATMENT OF LEACHATE WITH DISCHARGE TO A PHYTO-CAP TO CREATE A SELF-SUSTAINING LANDFILL: INTERIM RESULTS FROM A PILOT STUDY PROGRAM

Author / presenter: Mark S. Mallamo, P.E., DEE, Jeremy W.F. Morris, Ph.D., and Carrie H. Pendleton, msm@dswa.com

ABSTRACT

The goal of the project presented in this paper is to create a self-sustaining closed landfill unit through the treatment of all leachate generated by the unit in wetlands located on the landfill cell. Currently, installation of a phyto-cap on the landfill unit is proposed to take up all the treated effluent, resulting in no discharge to the environment. More passive long-term effluent disposal methods through the use of alternatives to pumping may be explored at a later date, depending on the long-term success of the wetlands and phyto-cap to treat and reduce leachate generation. This technology combination is most applicable to older landfill cells which may have been closed under less strict regulatory regimes than currently imposed by the U.S. Environmental Protection Agency (USEPA). Older landfills also have relatively mild leachate and lower gas production rates, which allow the use of simpler systems to control these potential emissions. It is anticipated that the project will demonstrate that the above approach is an effective method for management of leachate under circumstances that are commonly found in older landfills where cost, space, and environmental concerns limit the owners' long-term options.

Title: THE "MASTER PLAN" FOR THE REMEDIATION OF THE PORTO MARGHERA (ITALY) INDUSTRIAL AREA : PREMISES AND MAIN ACTIONS

Author / presenter: Andrea Barbanti, Roberto Casarin, Erminio Chiozzotto, Enrico De Polignol, Giuliano Vendrame, Marco Zanetti
andrea.barbanti@thetis.it

ABSTRACT

The Venice-Porto Marghera Site (D.M.468/2001) extends for about 6000 ha and represents one of the biggest contaminated sites in Italy. The industrial area was established in the 20's, reclaiming shallows and salt-marshes of the Venice Lagoon with dredged sediments and industrial wastes. The organic and inorganic contaminants present at high levels in sediments, soils and groundwaters represent a threat for people living and working in the area, but also for the whole Venice Lagoon ecosystem.

In 1998, central and local Administrations together with the most relevant industry located in the area, signed a voluntary Agreement to promote its overall environmental remediation and at the same time to maintain the industrial production, adopting environmentally compliant processes and pollution abatement technologies.

Within this framework, a “*Master Plan*” of intervention has been developed, in order to establish and coordinate the measures for the remediation of the area. The process of analysis, proposal and discussion of the *Master Plan* involved, for more than two years, all the relevant national and local Administrations and a number of stakeholders. The main strategic actions defined in the document finally approved are: (i) the confinement of the pollution of soils and groundwater within the area, to be accomplished in the short-mid term through hydraulic barriers and the permanent sealing off of about 42 km of embankments along the industrial canals, and about 8.5 km on their backside; (ii) the dredging of about 6.4 millions of cubic meters of sediments from the industrial canals; (iii) the remediation of the soils, in accordance to D.M. 471/1999, with a priority based on environmental, technical, socio-economical criteria on about 400 ha of priority areas.

A system of integrated infrastructures is planned in order to support and accelerate the remediation: sites to store soils and sediments, permanently or temporarily, for subsequent treatments; treatment plants for the wide spread of contaminant association present on the site. The *Master Plan* includes also activities devoted to the expansion and integration of the available knowledge: the characterization of the whole D.M.468/2001 contaminated site; monitoring plans extended in time; the development of tools to manage data and support the design of local measures. The overall plan is designed to be completed in about 10 years and has a total cost of about 1,87 millions Euros, to be shared between public and private subjects, depending on the area and the intervention.

Title: ACCUMULATION CHAMBER AS CONTROL SYSTEM FOR LONG-TERM GAS EMISSION IMPACT OF MSW LANDFILLING: PRELIMINARY EXPERIMENTAL RESULTS AND ELABORATIONS ON ITALIAN PROVINCIAL SCALE

Author / presenter: Bruno Capaccioni, Mariano Didero, Luca Pirillo, Paola Scartoni, Fabio Tatàno, b.capaccioni@uniurb.it

ABSTRACT

On site CO₂ flux () measurements with the interesting accumulation chamber system were carried out in no. 5 MSW (active and closed) landfills located in the territory of the Province of Arezzo (Tuscany Region). As a whole, measured fluxes ranged up to 40,261 gCO₂ m⁻² d⁻¹. Corresponding ln (_CO₂) maps were counterchecked, revealing a possible, preliminary geometrical classification of uncontrolled biogas dispersion: diffuse dispersion (internal), lateral/angular dispersion (internal), and external dispersion. Also specific (volume and surface) uncontrolled biogas emissions were graphically compared for the monitored inactive facilities.

Title: METHODOLOGY FOR ESTIMATING TYPES AND QUANTITY OF LANDFILLED SOLID WASTE: THE CASE OF MYTILENE MUNICIPALITY (GREECE)

Author / presenter: Efthimios Tagaris , Rafaella Eleni P. Sotiropoulou, Constantinos P. Halvadakis
etag@env.aegean.gr

ABSTRACT

The quantity and types of waste disposed in landfills are necessary data in order to study and upgrade Waste Management Systems. The lack of official records regarding waste mass as well as the time that the vehicles arrive at and depart from the landfill make any attempt to upgrade Waste Management Systems extremely difficult. The absence of a weighing scale at the majority of landfill sites makes the estimation of the waste quantity that is disposed into the landfill uncertain. In order to estimate needed data on waste disposed in the Mytilene Municipality's landfill in Greece, seven (7) studies took place during 1989 - 1998. The studies had duration time one or two weeks, in different seasons. In order to acquire all the necessary information concerning landfilled waste, data concerning incoming vehicles were collected. Based on the recorded waste type and quantity landfilled daily and the time that vehicles enter and remain inside the landfill, useful conclusions can be obtained for further improving landfill operation.

Title: BENCHMARKING OF QUANTIFICATION AND SEPARATION TECHNIQUES FOR HEAVY METALS IN LEACHATE FROM LAB-SCALE LANDFILL

Author / presenter: E. Beccaloni, M. R. Bon, L. Musmeci, S. Scaffoni, E. Stacul,
suolo@iss.it

ABSTRACT

The present survey has the goal of benchmarking different treatment methods of leachate, in order to stress their influence on quantitative analysis of inorganic micropollutants (in particular Cd, Cr, Cu, Ni, Pb and Zn), both on liquid phase and suspended solids.

Leachate investigated has been produced by a lab-scale landfill built up with MBPs wastes; a proper characterization of the organic solid waste has been carried out, by a chemical and microbiological point of view.

Following treatment procedures used to quantify and separate heavy metals have been considered: mineralization of leachate with Aqua Regia at two different pressure and temperature values, centrifugation at 8000 rpm and filtration by cellulose membrane with net light of pores at 0,80 m.

First results have shown that high-pressure mineralization process is inclined to produce outcomes slightly affected by operative drawbacks, whereas significant differences have been found between centrifugation and filtration methods. The last one, in fact, allows to separate heavy metals more efficiently than centrifugation step, providing higher percentage of recovery.

Session: Waste Collection Transport/Urban Hygiene

Title: A MODERN CONCEPT FOR WASTE COLLECTION IN BIG CITIES.

Author /Presenter: Christer Öjdemark, christer.ojdemark@envac.se

ABSTRACT

Waste collection in high-density areas like big cities and metropolitan areas, has become a more and more challenging task for the local authorities. Demands for sustainable solutions considering increased waste volumes, curbside collection, source separation of several fractions, increased traffic problems, clean streets and safety are difficult to meet with conventional methods. One solution, which can address most of these issues, is the Automated Waste Collection System (AWCS).

The solution, which was invented 40 years ago in Sweden, has gained international market acceptance over the last 10 years and is now becoming a standard in many large international cities like Barcelona, Seville, Hong Kong, Singapore, Stockholm, Gothenburg, Copenhagen and many more.

By using a net of underground pipes, between the waste inlets and a central collection station, together with all other infrastructure facilities like water, sewage, electricity, communication etc., the need for waste containers in the streets and refuse trucks driving around to all collection points have disappeared. This creates a local environment with heavily reduced traffic, high hygienic standards and lower noise levels.

Title: IMPLEMENTING WASTE TARIFF IN THE MANTOVA PROVINCE: WASTE PRODUCTION RATES ASSESSMENT FROM HOUSEHOLD AND BUSINESS ACTIVITIES

Author /Presenter: Federica Alessi, Maurizio Sali, Walter Ganapini
federica.alessi@katamail.com

ABSTRACT

The Province of Mantova (Italy 380.000 inhabitants), in order to implement the new waste tariff in substitution of the obsolete waste tax (€/m² of surface), has carried out a direct measurement campaign in the estimate of municipal waste production from a sample statistically representative, of households (H) and business activities (BA) relevant for the territory. The study provided estimates of waste production (divided in food, paper, glass, plastic, Aluminum, small boxes and residual waste) for different families' sizes (1, 2, 3, 4, 5 or more inhabitants) and different business activities relevant for the territory; 2.947 H and 608 BA have given their contribute to the project.

The results highlight that approximately 62% of municipal waste is produced by BA. Specific waste production from H and BA have been compared with existing national data; the median waste production per family results coherent with the national assumptions and lower especially for H of 4 and 5+ inhabitants, while the median waste production per BA results to be lower than national assumptions especially for activities with high production of organic waste. The Provincial survey's outcomes allow local Municipalities to adopt parameters (waste production rate indicators) for specific urban solid waste production that better suite the revision on waste taxes.

Title: APPROACH FOR CALCULATING THE AMOUNT AND THE COMPOSITION OF BIO-WASTE POTENTIAL AND COLLECTED BIO-WASTE MATERIAL**Author /Presenter:** Schmidt Sonja, Pahl-Wostl Claudia
sschmid@usf.uni-osnabrueck.de**ABSTRACT**

In this paper the calculation principles of bio-waste potential and different collected bio-waste materials are presented. The results of case studies and of a literature examination are given to define number and contribution of the relevant operands for the calculation. The paper lists the assumptions and describes the calculations principles of the amount and composition of the bio-waste potential. The calculation of the amount of the bio-waste potential previously associated with uncertainties is explained explicitly, e.g. taking into account different types of building and collection systems. Furthermore the calculation principles of bio-waste of private gardening, of the organic portion of residual waste and of separately collected bio-waste materials are given. Special emphasis is put on the examination of different types of collection systems, e.g. the separate collection by bring system and pick-up system, and on their influence on the collection behaviour of citizens. The approach is transferred in a software supporting Life Cycle Assessments. It can be included in decision support systems or in studies assessing bio-waste management systems because it takes into account different collection strategies and lays the basis of the mass flow of bio-waste materials, e.g. forming the functional unit of Life Cycle Assessment.

Title: PLANNING, DATA MONITORING, RESULTS OBTAINED FOR THE SEPARATE WASTE COLLECTION PROJECT CARRIED OUT FOR PERUGIA CITY COUNCIL. COMPARISON WITH OTHER LOCAL AUTHORITIES**Author /Presenter:** V. Piro, M. Pera, m.pera@gesenu.it**ABSTRACT**

This paper presents the principal results obtained by the separate waste collection service carried out in Perugia City Council area. In particular, different collection methods were used: door-to-door, containers near habitations and roadside collection for the different kinds of waste.

Monitoring systems for each kind of waste were used to calculate the efficiency of the collection systems based on the organisational model adopted. Data from other local authorities in Umbria were used for comparison in order to standardise the results obtained in terms of the productivity of separate collection, according to the organisational systems used.

Particular attention was paid to the separate collection of organic waste. The monitoring of collection systems of organic waste in different local authorities was carried out, which permitted the definition of technical and organisational standards of reference in terms of specific productivity, yield etc.

Title: AN INTEGRATED APPROACH FOR MANAGING MSW IN A BETTER ECONOMIC AND MORE ENVIRONMENTALLY SUSTAINABLE WAY

Author /Presenter: Paolo Viotti, Giuseppe Marella, Michele Leccese, Paolo Di Genova, michele.leccese@uniroma1.it

ABSTRACT

Municipal Solid Waste (MSW) management is a major concern for all urban areas, which needs to be accomplished referring to integrated strategies.

Those strategies can be effective only as a result of commonly shared analyses and choices with respect to the entire involved territory.

This paper presents a model for the implementation of integrated MSW management policies. Different viable scenarios need to be assumed first, based on the environmental, social, economic and technological conditions of the specific area and on its developing potential. The model provides the best SW flows allocation/distribution among the available treatment and disposal options by minimizing the total cost by means of a optimization procedure. The environmental impact of the resulting scenario can be estimated, then, by means of an LCA based procedure.

Such a model can serve as a support in decision making for both governmental and nongovernmental institutions involved in the planning of MSW management strategies. It can easily be adapted to different scenarios or modified for further development.

Title: ORGANIZATION OF THE VEHICLE MAINTENANCE SERVICE IN A WASTE MANAGEMENT COMPANY OF A BIG CITY

Author /Presenter: Giovanni Ficon, Marco Sori, Carlo Brutti, Maria Rosaria Boni, Augusto Simmi, giovanni.ficon@amaroma.it

ABSTRACT

The attention of this article is essentially aimed at introducing a new approach on vehicle maintenance service taking into consideration vehicles and equipment for waste collection, vehicles dedicated to sweeping and road cleaning services and the premises thanks to which a Waste Management Company of a big city guarantees the presence of its vehicles that are in order to operate within Refuse Collection Management Cycle along with transportation to Landfills, and Sweeping and Road Cleaning Services.

Title: PROBLEMS RELATING TO THE CARRYING OUT OF URBAN CLEANSING SERVICES IN AN EMERGENCY SITUATION IN THE CAMPANIA REGION

Author /Presenter: F. Sassaroli, G. Bisogno, segreteria@setaspa.191.it

ABSTRACT

2001 and 2002 were dramatic years for waste management in Campania. The closure of landfills (mostly the only means for disposing of household waste) caused great problems for local authorities and inhabitants as the rubbish piled up in the streets. Temporary storage sites became effectively rubbish tips, and skips for temporary storage were impossible to find or extremely expensive to hire or buy. Three years later many things have changed. Even if the situation put great strain on local authorities, residents and workers, it had the positive effect of recognising a culture that was considered “optional” before and of improving organisational capabilities. There is also a different way of thinking as a result of this difficult situation.

Thanks also to help from the Government Commission for the Waste Emergency in Campania, many local authorities have changed their waste management methods, and introduced separate collection for all kinds of waste.

The emergency showed up the failure of Italian policy with respect to the environment. There still is no serious attempt to face the problem of reducing the growing mountains of waste. The transformation of waste collection methods has led to new ways of thinking about tenders and service contracts in the sector, especially in relation to suitable costs. Before, the only criterion for awarding contracts was the lowest cost, with all the negative consequences for the environment and personnel when the cost didn't even cover the provision of the service. Sometimes the local authorities were not even aware of what was a fair cost. With the emergency, the people involved have woken up to the fact that price is not the only important thing and a new approach taking into consideration social, environmental, legal, cultural, moral as well as economic factors has begun to be used.

In this new context, many firms offering the lowest price, often at below cost, have closed down, and only firms using a different logic have survived. Today, thanks also to controls by the Government Commission for the Emergency in Campania, the cost of services is reaching a fair market price for an “integrated cycle of waste” according to norms set out in Ordinance 319 which apply to the regions.

Finally, we should underline that the costs of the new waste management methods in Campania are perhaps excessively affected by the considerable size of operating structures provided by past policy decisions.

TITLE: DEVELOPMENTS IN THE INTERMODAL TRANSPORT OF WASTES AND RECYCLABLES IN THE UK**Author /Presenter:** Dr Robin Curry, rcurry@envirocentre.co.uk**ABSTRACT**

As one of the countries of the European Union most dependent on landfill disposal for the management of wastes, the UK faces a revolution in waste management practices over the coming years as it seeks to deliver the infrastructure required to meet a range of sustainable waste management targets and objectives. This presents the opportunity to look strategically at the choice of locations for waste management infrastructure and the options for moving materials between these facilities. Thus, Intermodal Transport (Road, Rail, Canals, Inland Waterways, Short Sea Shipping) of wastes is receiving increasing attention in the UK. This has resulted in the initiation of two major research studies, to assess the potential contribution of the intermodal transport of wastes and recyclables to this infrastructural development. These studies attempt to synthesise the converging fields of Intermodal Transport and Integrated Waste Management with a range of concepts and approaches from the emerging field of Industrial Ecology, including Regional Nodes/Regional Specialisation, Environmental Technology Clusters, Eco-Industrial Sites and Industrial Symbiosis.

Title: RECYCLED AGGREGATES FROM CIVIL DEMOLITION**Author / presenter:** R. Mancini, E. Garbarino, elena.garbarino@polito.it**ABSTRACT**

Till now C&DW have been wrongly considered as a waste, disregarding their intrinsic capacity of being employed, through appropriate processing, to produce aggregates with a wide range of possible uses, up to concrete aggregates that can compete with some natural aggregates. The aim of this study consists in the treatment of recycled materials that can be reutilized in the same original applications. For this reason building rubble with high percentage of concrete, arising from the demolition of a civil building, has been tested. The building of Fratelli Garrone street in Turin was characterised by a length of 53 m, a width of 11.5 m and a height of 36 m, with a total weight of 8700 t and was demolished by blasting action. Selected concrete waste from the demolition operation has been processed with different laboratory machines, in order to obtain all the aggregates for preparing the concrete mix with the addition of cement and water. Components were characterised through Los Angeles and sieving tests. The 7 and 28 days strength features of the recycled concrete were compared to the strength of probes cored in the building for the mechanical characterisation

Title: A COMPUTERISED SYSTEM APPLIED TO A SOLID WASTE MANAGEMENT SYSTEM**Author / presenter:** Elsa Branco, Joaquim Bucho, João Pedro Rodrigues, Cristina Saraiva' valorsul@valorsul.pt**ABSTRACT**

Valorsul is a public company that processes non-hazardous solid wastes from Lisbon area. For this purpose the company has developed an integrated management system. The aim of this paper is to present how a computerised system can help in the waste information gathering, storage, systematisation and output between Valorsul's operational facilities.

In each of the Valorsul's operational facilities there is a weight bridge. In average, every day there are approximately 500 trucks delivering wastes at Valorsul. This information is managed and stored in our Weight System (named SIPI). The information related with the waste deliveries is transferred to the Management Accounting and Financial System (named GIAF) when Valorsul determines it. From the moment that Valorsul's operational facilities give this instruction to GIAF, it prepares the invoices that are sent to the clients, and all information is registered in an accounting module. The master of the entirely system is the Weight System, where all new entities are created.

Any changes on information in the relational databases, concerning the Weight System, are automatically replicated to the operational facilities. A third system called Maintenance and Purchase System (named Maximo), also receives information about the entities from the Weight System.

Title: NECESSARY PHYSICAL STRUCTURES FOR THE CARRYING OUT OF THE SERVICE OF URBAN WASTE MANAGEMENT IN THE CITY OF ROME**Author / presenter:** Giuseppe Rubrichi, Fabrizio Grilli, Roberto Paneli, Antonella Fiore, giuseppe.rubrichi@amaroma.it**ABSTRACT**

To face the problem of the urban hygiene and of refuse management in the city of Rome, AMA S.p.A., together with the implementation of the technological equipments, has prepared a development plan of dedicated infrastructures. The main goal is to guarantee a widespread distribution of logistic support on the territory in order to be able to offer an adequate service to meet the needs of the city helping out with regards to the accessibility on behalf of the citizen-consumer at some of the structures that allow the recycling of refuse while promoting an effective image of the Company. According to the above mentioned each of the 19 Municipalities have been divided into homogeneous zones according to parameters such as surface, density, and to the needs detected, in order to built appropriate premises. Following deep analyses, and on the basis of a long lasting experience, specific building typologies have been planned and realized from the detection of refuse collection management, making use of as much as possible specific modular solutions.

**Title: WASTE COLLECTION, TRANSPORT AND TREATMENT COSTS –
A SPREADSHEET APPROACH****Author / presenter:** Sergej LAURENCIC
sergej.laurencic@gov.si**ABSTRACT**

Based on the so called prime calculation (german: die Urkalkulation) the daily costs of a rear-loader (collection vehicle) are calculated. Daily costs, the collection frequency of the different waste materials and the team efficiency (number of emptied dustbins per shift) are the input data to estimate the collection and transport costs of the different waste fractions. Different treatment costs (sorting, composting, landfilling) for certain fractions are added. Waste compression in dependence of collection frequency is taken into account.

Based on the 120, 240 and 1100 litres bins and the weekly produced waste quantity of 40 litres per person from household plus some other parameters, the waste fee per person in the certain time interval is calculated.

The waste quantity (mass in Mg, volume in m³) forecasting model is presented. All the calculations and the forecasting model are prepared in the Microsoft Excel 2000.

**Title: UNIQUE ELECTRIC-POWERED REFUSE REAR LOADER DEVELOPED IN
SWEDEN****Author / presenter:** Kurt Lindman, Carl Jensen ,Christian Kallerdahl,
Lars Thulin, carl.jensen@renova.se**ABSTRACT**

The principal innovation of the new waste collection vehicle developed by Renova AB (which we have termed 'Eco-vehicle') is the application of electric hybrid technology at the collection site during the collection procedure. When the Eco-vehicle stops at the collection site, its main engine is automatically switched off while conventional vehicles would be idling and driving the lifting and compaction systems. Instead, in the Eco-vehicle, an electric powered engine drives the hydraulics system that effects the lifting and compaction of the waste. This improves the environmental performance of the waste collection with respect to noise, fuel consumption, energy use and emissions.

Measurements carried out show a decrease in fuel consumption of about 21% and a decrease in energy use of about 18%. The greatest reduction in noise is obtained during the actual collection of the bins when the main engine is switched off and is thus completely silent; while conventional vehicles would be idling, causing a noise level of up to 70 dBA in the vicinity of the vehicle. In terms of time, this procedure is also the longest, representing about 50% of the total time spent at the collection site. During the loading and compaction of waste, a reduction of up to 25 dBA has been observed in the vicinity of the vehicle.

Title: OPTIMISATION OF THE URBAN SOLID WASTE COLLECTION AND TRANSPORT SYSTEM IN THE CITY OF PERUGIA**Author / presenter:** M. Pera, M. Sartore, R. Sorrentino
m.pera@gesenu.it**ABSTRACT**

The main aim of this work concerns the definition and experimental implementation of an information technology system to support the planning and management of the urban solid waste collection service. The large amount of information technology at the disposal of the GESENU Spa company of Perugia was integrated and put in order, and the latest generation of software packages was chosen and modified according to the particular use to be made of it. The territory covered by the commune (local authority area) of Perugia is divided into 20 zones for the collection of waste.

Four of these were chosen as statistically significant areas in which to carry out the experimental application of the new systems, covering areas including historic town centres as well as the suburbs, urban and rural areas.

Two different hypotheses for the project were formulated after analysing the existing situation and the main criteria. The first consisted of the “tactical planning” of the routes to be followed by the vehicles used, the second can be described as a “strategic approach” which also involved the spatial redefinition of the zones, without changing the numerous other obligations. The implementation of the second approach, which radically changed the configuration of the original four zones and reduced them to three, has produced absolutely unexpected results which go far beyond those which were hoped for.

Title: MIDWASTE, AN ASSOCIATION OF PUBLIC ENTERPRISES**Author / presenter:** Roel Wolters, r.wolters@midwaste.nl**ABSTRACT**

Midwaste is a union of six publicly controlled waste collecting enterprises. It concerns a union in the form of a cooperative. This legal entity form was selected specifically because of the need to combine the two apparently irreconcilable aspects of, on the one hand, achieving economies of scale thus ensuring continuity and efficiency and, on the other hand, maintaining close contacts with the Principal which is to say the Municipality that owns the enterprise. The first reason for the need of this association is the up-scaling occurring at both public and private waste processing and collecting companies. The second reason is the clearly discernible trend of increasing technical complexity and capital intensity. Individually the participating enterprises possess insufficient scale to continue delivering, in the long term, the high quality service as they do now. The association will create the critical mass required. All enterprises involved have a very strong regional origin and base. This is their strength and this is manifested in the intensive collaboration that exists between Municipality and enterprise. In this context shaping and implementing policy takes the form of co-makership rather than of a Principal - Contractor relationship. The selected cooperative form, while retaining the autonomy of the enterprises involved, prevents any obstacles occurring to this valuable relationship.

Session: Strategies for Developing Companies**Title: ADDRESSING CHANGES THROUGH MSW-LCA: SÃO PAULO AND TOKYO CASES****Author /Presenter:** Mara R. Mendes, Toshiya Aramaki, Keisuke Hanaki
mendes@iges.or.jp**ABSTRACT**

This study addresses the application of Life Cycle Assessment (LCA) to evaluate the environmental consequences of Municipal Solid Waste (MSW) management policies. Two case studies were performed where the environmental impacts of options for MSW treatment in São Paulo City and the Tokyo 23-ward Area were evaluated in response to different conditions regarding waste source separation and changes in fuel sources for electric power generation. Several waste treatment options were evaluated, such as incineration, gasification, composting, biogasification, and landfilling. Source separation of waste and energy source policies were assessed and their influence on global warming, acidification, and nutrient enrichment potentials were compared to that of the default case (present situation).

It was found that their effect is different in waste treatments that recover or consume electricity. Moreover, the influences of source separation and changes on the electric power profile were found to be different in São Paulo and Tokyo, indicating that this type of analysis has to be site-specific. Through this study it was confirmed that the results obtained from MSW-LCA can support decision-makers in several ways, for instance by providing relevant information about the environmental impacts of waste treatment options, influence of policies, and improvement obtained through changes in waste management.

Title: BUILDING MUNICIPAL CAPACITY OR STRATEGIC WASTE ANAGEMENT PLANNING**Author /Presenter:** Jane E. Olley , David C. Wilson, Adam D. Read and Verele de Vreede**ABSTRACT**

This paper is based on the findings of a research project financed by DFID between November 2001 and October 2003. The aim of the project was to determine the effectiveness of the Strategic Planning Guide (SPG) (www.worldbank.org/urban/solidwm/erm/start_up.pdf) in assisting decision-makers in planning Integrated Sustainable Waste Management (ISWM) systems. Project teams worked alongside decision-makers and their planning committees to develop a framework document from which a full Strategic Plan could be developed. The three target cities were: Bangalore, India; Bamako, Mali; and La Ceiba, Honduras. Each group sought to apply the SPG methodology. New planning tools were developed where stakeholders identified a specific need not covered by the SPG. These planning tools have been published as a series of key-sheets available at www.wastekeysheets.net

The main challenge of the project was found to be achieving a balance between ensuring comprehensive stakeholder involvement while retaining political support from key decision makers. Essential to this was establishing the legitimacy of participating stakeholders in the eyes of municipal government. In order to have a truly participative process, it was necessary to employ significant resources in capacity building. Where a balance was achieved, the final result is a planning framework, which is accepted by all stakeholders and has been formally adopted by municipal government.

Session: Social and Communications issues

Title: ANALYSIS AND PUBLIC COMMUNICATION OF RATES FOR PUBLIC SERVICES

Author / presenter: Enrique Cázares, Belzahet Treviño
ecazares@itesm.mx

ABSTRACT

Costs and rates of Water Utilities (WU) depend on many factors, hindering a direct and fair comparison among them. This project presents a methodology to obtain a Rate Index that allows an objective comparison of rates among WU. A Basic Cost was estimated assuming that each WU operates at minimum efficiency levels. Administration, Operation, Depreciation and Other Costs were included in the estimation of the Basic Cost. An Integral Cost was estimated by adding Future Water and Quality in the Service Costs to the Basic Cost. Actual Costs will be usually above these Basic and Integral Cost due to inefficiencies of the WU. A Rate Index was developed to indicate the relative position of the Actual Rate compared with the Basic and the Integral Costs for each WU. Rate Index provides a tool to indicate if the Rate is adequate to recover Basic and Integral Costs assuming a minimum level of efficiency. Rates below the Basic Cost indicate that WU cannot operate without a subsidy. Rates between Basic and Integral Costs indicate that WU is recovering Basic Cost and part of the Integral. Rates above Integral Cost show that the WU should have a profit if it operates at minimum efficiency levels.

Title: THE APPLICATION OF THE “RESPONSIBILITY PRINCIPLE” IN TWO MEMBER STATES OF THE EUROPEAN UNION

Author / presenter: Elisa Squerzanti, elisa.squerzanti@uni-bielefeld.de

ABSTRACT

The EC Directives (94/62 and 2004/12) encourage Member States to implement the principles of “shared and producer responsibility.” This paper will consider their application in national law and their implementation in integrated waste collection systems. To understand whether the normative application of these principles influences working practices, two collecting systems (the Italian and the German compliance schemes) are taken into consideration. This study aims at verifying, whether observable differences in the implementation of these principles can be ascribed to different political, organisational and regulative cultures embedded within these countries.

The methodology used is based on a comparison between law texts and on interviews with the representatives of the governance structures leading the compliance schemes (CONAI, DSD, Interseroh). When comparing the two regulatory systems one terminological variation is to be observed: while Italian framework law refers to “shared responsibility”, German lawmakers preferred to adopt the “producer responsibility” principle. Either set of regulation does not exclude an implicit application of the principle that has not been mentioned.

The comparison between German (prevalently door to door) and Italian (prevalently curbside) approaches for waste collection revealed also a different level in the individual responsibility.

Title: LCA AND INTEGRATED ENVIRONMENTAL MONITORING SYSTEM AS TOOLS FOR EVALUATION OF ENVIRONMENTAL IMPACT

Author / presenter: Luciano Morselli, Luzi Joseph, Bartoli Michele,
Vassura Ivano, Fabrizio Passarini
luciano.morselli@unibo.it

ABSTRACT

Every industrial plant, in particular those dealing with waste management, are directly related to a significant environmental impact, whose consequences induce from local to global problems. A necessary evaluation has to be carried out by choosing the technological solutions which provide the maximum environmental gain (or the minimum damage); thus, the complete life-cycle of the process must be investigated, analysing the critical steps and the possible improvements. However, due to the direct contamination produced by stack emission in the vicinity, a deeper territorial investigation, aimed to the assessment of the sites most affected by the fallout of plant pollutants, has to be performed.

Life Cycle Assessment and Environmental Integrated Monitoring System were identified as the two proper instruments for a thorough description of the environmental impact of an industrial plant. In this work, the case study of a Municipal Solid Waste Incinerator is presented. Results indicate that energy recovery can greatly mitigate incineration impacts, making them comparable or lower than those of an Italian average power plant, for the same amount of energy produced. Furthermore, exploring the fate of some incinerator pollution tracers (heavy metals), significant correlations were found between the same parameters both in industrial and in environmental matrices (in particular, atmospheric depositions).

Title: APPLICATION OF EPR TO THE MANAGEMENT OF BUILDING'S LIFE CYCLE

Author / presenter: Narikiyo Sachiko, Yagishita Masaharu, Nagoya University

ABSTRACT

Construction waste has the character of heavy, mass waste producing etc. With these reasons, construction waste is disposed domestically. On the other hand, the population is projected to decline in 21st century in Japan.

In this paper, we identify the social problem caused by increase of waste generation from building demolitions and by the depopulation, such as demand-supply imbalance of recyclables and rapid increase of adverse effects against environment. On the basis of this knowledge, we consider policies from the viewpoint of environmental law and policy. From this viewpoint, it is important which countermeasures we should take and we focus on EPR approach.

Application of EPR to the problem leads to decrease of social burden by promoting the efficiency of building's life cycle management.

This study suggests that application of EPR to the management of building's life cycle is possible.

Title: FEDERAMBIENTE AND THE GREEN PUBLIC PROCUREMENT FOR URBAN HYGIENE PUBLIC COMPANIES**Author / presenter:** **Valentina Cipriano, Irene Ivoi, Mario Santi**
tecnico@federambiente.it**ABSTRACT**

In 2004 Federambiente has elaborated its report “The Green Public Procurement for Urban Hygiene Public Companies – Pre-feasibility Analysis – Criteria for the definition of purchasing specifications for some goods and services” in order to favour the implementation of Green Public Procurement among urban hygiene companies. The study consists in a regulatory framework summarising the main legal references on the subject, the results of a purchase survey carried out on some of Federambiente’s member companies, as well as an explanation of possible GPP application methods.

To this end, one identified three main intervention areas:

- Vehicle fleet (purchasing and management).
- Paper and office equipment in general.
- Drinking water.

A number of environmental criteria, to be introduced at the purchasing stage, were selected for each area. The essential aim of such report is to favour the utilization of ecological products undertaking to divulge this practice among member companies by means of targeted activities.

Title: ENVIRONMENTAL COMMUNICATION – THE APPLYANCE ON WASTE MANAGEMENT**Author / presenter:** **Ana Luísa Loureiro , Joana Xavier , João Pedro Rodrigues,**
ana.loureiro@valorsul.pt**ABSTRACT**

All waste management projects need the acceptance of various stakeholders – politics, government, industry, communities, NGOs, scientific technicians as well as all other citizens.

Communication plays an increasingly important role in the establishment of these projects, because without the acceptance of the stakeholders, many of them cannot be efficiently realized. Several companies experienced the NIMBY SYNDROME during the construction or management of waste plants, with opposition and many obstacles, resulting in long delays and increased costs. The role of an effective environmental communication is not only to give technical information, but having effective communication strategies and measures, to obtain active and positive participation of citizen.

In Portugal, Valorsul had different experiences during the construction and functioning of a landfill, an incineration plant, a sorting plant and an anaerobic digestion plant. With specific campaigns and actions, it was possible to create acceptance and partnerships with companies, municipal authorities and local associations. Nowadays, and after the implementation of social, educational and monitoring programmes, Valorsul achieved public acceptance and is considered as a company that can be trusted.

Title: WASTE MANAGEMENT AND ROAD TRANSPORTATION OF DANGEROUS GOODS: COMPARING LEGISLATIONS

Author / presenter: Nicola G. Grillo, grillo@pxingegneria.it

ABSTRACT

“Waste” management has to be carried out according to the legislation dated 5 February 1997, No 22, and also taking into consideration the following effective, supplemental and modifying decrees. Transportation by road, key element of the fore mentioned “management”, is, for some kinds of substances, similar to the legislation “ADR” (acronym for European Agreement concerning the International carriage of Dangerous by Road), which was at first created to limit the risks during “dangerous goods” road transportation. The intervention aims at describing and targeting the correct management of various wastes, also respecting the legislation ADR; taking into consideration the fact that we refer to two different legislations belonging respectively to the environment and territory protection ministry and to the infrastructure and transportation ministry.

Title: BUILDING A SECOND GENERATION CO-REGULATORY SYSTEM - AUSTRALIA’S NATIONAL PACKAGING COVENANT

Author / presenter: Robert M. Joy, rob.joy@rmit.edu.au

ABSTRACT

It is now five years since the Australian Federal, State and Territory governments joined with sections of local government and firms across the packaging supply chain to establish the National Packaging Covenant. This innovative voluntary agreement aims to promote *product stewardship* through the application of the concept of *shared responsibility* for avoiding and reducing waste and promoting recycling of consumer packaging.

An important aspect of the arrangement has been the pledging by governments and industry of up to A\$34.9 million to assist local government to adopt best practice in kerbside recycling collections. The Covenant is backed by a regulatory safety net protecting its 600 or so industry signatories from unfair competition from nonsignatories. The Covenant was originally due to end in August 2004, but, with the agreement of the parties, its original five-year life span has been extended until April 2005 to allow time to conclude negotiations on whether to forge a new Covenant or to adopt alternative, perhaps regulatory, measures. This paper provides a “report card” on Australia’s voluntary National Packaging Covenant and its regulatory safety net, reflects on the lessons learned over the past five years and discusses a basis for a new and significantly more effective successor.

Title: GPP POLICIES IN THE MUNICIPALITY OF FERRARA**Author / presenter:** Valeria Nardo, corresponding.author@address.aa**ABSTRACT**

Ferrara is located in the north-east of Italy between Venice and Bologna (404.35 sq km, 131.000 inhabitants). The main economic activities are agriculture, tourism, commerce, small and medium businesses and hand made goods (There is also a chemical industry). While Ferrara offers an enviable quality of life for its inhabitants (cycle paths, thermal hot water central heating, the appreciation of green areas) the Council recognises that there is still room for improvement in terms of quality of life. To achieve these objectives, the City of Ferrara signed the Charter of European Cities in 1996 for sustainable development (the Charter of Aalborg). In 1999 the new administration drew up the special community project called "Agenda21 Locale" (a sustainable development project).

This project forms part of local politics, and provides for new methods of work between various sectors and groups linked to other local organisations to promote the concepts of Agenda 21 in three different areas: first within the local administration, then to the citizens and the third to national and international concerns and includes three strategic aims:

- Activating the Agenda21 Locale FORUM split into four areas.
- Production of a environmental balance sheet report.
- The GPP programme (Green Public Procurement).

Title: COST FUNCTIONS FOR MATERIAL RECOVERY AND COMPOSTING FACILITIES**Author / presenter:** Konstantinia T. Tsilemou, Demetrios C. Panagiotakopoulos, ntsilemo@civil.duth.gr**ABSTRACT**

The objective of this paper is to generate approximate cost functions for Mechanical- Biological Treatment (MBT) facilities, considering a combination of Material Recovery Facility (MRF) and Composting Facilities (CF).

Detailed designs are developed (simulated) for these facilities. Various design schemes are considered, for 24 different sizes, ranging from 10 to 1500 tons per day. For every alternative size, several design parameters (inflow waste composition, operational conditions, recovery coefficients, windrows morphology and arrangements, windrows cover, equipment size, type and efficiency) are considered, each within a wide range of values. In addition, the alternative of co-treatment with yard waste is considered.

The simulation model generates cost functions, both for the initial investment cost and the operational and maintenance cost. Some of the major results for data valid at least in Greece: There appear to exist strong economies of scale up to the range of 300-400 tons/day. Thereafter, economies of scale fade away. Cost per ton ranges from below € 50 to above € 500 for the whole facility. Waste composition does not affect the total cost, but, as expected, it affects the cost distribution between the Material Recovery subsystem (56 to 71%) and the Composting subsystem (29 to 44%).

Title: RECYCLING COLLECTION CENTRES AROUND LAKE TRASIMENO: AN EXPERIMENT IN INVOLVING THE PUBLIC IN RECYCLING INITIATIVES WITH FINANCIAL INCENTIVES

Author / presenter: L. Sisani, tsa@tsaweb.it

ABSTRACT

This recycling project was set up by the TSA S.p.a. company (Società Trasimeno Servizi Ambientali) in 1998 in the part of Umbria bordering on the city of Perugia, comprising 9 small local authorities with a low population density and a total of approximately 65,000 inhabitants. There are 13 collection centres, called “riciclerie”, where residents can take their separated waste and deposit it in the appropriate bins in the centre.

Each of the 13 collection centres, spread all around the Trasimeno area, has specialised personnel, and is equipped with an electronic system which weighs and records the waste brought in by every resident. Thus the amount of separate household waste brought in by each resident every calendar year can be calculated. The Local Authorities have provided tables setting out the relative values of the waste, which are used to calculate the financial incentive to be deducted from the local tax on waste (TARSU). These financial incentives, together with a campaign for education and information about the benefits to the environment from recycling waste, have resulted in a strong involvement of the public. As a result, around 20% of household waste in the area is collected in the form of separate collection for recycling.

The simplicity of this system of separate collection has involved a small increase in costs, but these have been almost completely covered, partly by an increase in the income from waste sent for recycling to CONAI (National Consortium for Packing) and partly from savings in the costs of landfill sites.

Title: ESTIMATING COSTS FOR SOLID WASTE TREATMENT FACILITIES

Author / presenter: Konstantinia T. Tsilemou(, Demetrios
C. Panagiotakopoulos, ntsilemo@civil.duth.gr

ABSTRACT

The objective of this paper is to explore the problems arising in getting cost estimates from available published data, to suggest a process for generating cost functions relating initial investment cost and operating cost with facility size and to present such cost functions, relevant to European states, for selected types of facilities. Regarding the problems of available scarce data, one needs to deal with variations in size, technology, year of construction, working conditions, level of technological automation, capacity utilization rate, composition of inflowing waste, waste management policies, etc. The paper discusses the proper use of statistical analyses in such cases of fragmented data; moreover it comments on the usual misuses of statistics and the danger of getting erroneous results. The suggested process for generating “good” cost functions is pivoted around the question of “acceptable” approximation level. Finally, approximate cost curves are suggested for waste-to-energy facilities, landfilling facilities and composting facilities.

Title: WASTE MANAGEMENT AND STRATEGIES OF PREVENTION**Author / presenter: Lucia Venturi****ABSTRACT**

The refusals in Italy grow more quickly than the gross inside Product: according to various sources it emerges that from 1997 to 2002 the production of urban refusals has passed by 26 to 30 million tons, with an increase 12% percentage. The 110 million of tons are broadly overcome the year, if the are added around 49 million tons of special refusals and the around 40 million tons of inactive from construction and demolition. To European level the total one of the refusals (urban and special) it amounts to 1,3 million tons - around 3,5 tons to person - and the alone quota of the urban solid refusals is currently equal to around 550 kgs to head, but already the respects OECDs foresee that it will become of 640 kgs in 2020.

Title: PREVENTION AND RECYCLING OF WASTE IN THE PRIULA CONSORTIUM BY PAYT CHARGE**Author / presenter: Contò Paolo, Pizzolon Pamela, Rasera Michele, Tommasini Sergio, Zanini Luca, paolo.conto@priula.it****ABSTRACT**

The Priula Consortium co-ordinates the management schemes of 22 municipalities involving about 200.000 inhabitants. In the year 2000 the Priula Consortium changed collection system from road container to Door to Door.

All materials are collected with plastic bins of different colours and volume, corresponding to the specific production of utilities. Each wheel bin assigned for residual waste to HH and activities is provided with a transponder that is automatically read during the emptying of the container. The waste charge is composed of a fixed quota and a variable one. For householders fixed quota is equal for all families and variable quota is proportional to the volume of the bin used and determining the number of emptying performed on the wheel bin for residual waste. For non-domestic utilities, residual waste the system is as for HH and for recyclable waste the charge depends on the volume and number of containers assigned to each utility and the emptying frequencies if they exceed the standard capacities. The effect of PAYT charges is rising of source separation, reduction of residual waste and reduction of total amount of MSW, and has taken advantage of introducing the PAYT charge on a district level, thus optimising investment cost and administration efforts in designing, testing and applying the scheme.

Session: City Strategies in Waste Management**Title: STRATEGIC SOLID WASTE MANAGEMENT IN CITIES IN JAPAN****Author / presenter: Masaru Tanaka**
maxta@cc.okayama-u.ac.jp**ABSTRACT**

SWM systems have always been compatible with the societal need at every point of time. In 1950's it was oriented towards maintaining public health standards mainly to control infectious diseases. While in 1970's energy generation was considered as the vital aspect of the system. In 1990's reduction in waste generation and recycling were officially incorporated in the waste management regulation. By enacting basic law in 2000 A.D.; the society is poised to become a recycling based society in its drive towards sustainable society.

In order to orient the society with best possible SWM system variety of acts have been formulated and modified. In the 30 years from the enactment of the original "Waste Disposal and Public Cleansing Law", the Japanese people's life style and economic structure have undergone drastic changes with their economic affluence in the background, with resultant quantitative growth and diversity in nature of wastes. Mass-production and mass-consumption in the human society have resulted in the depletion of forests, mineral resources, etc., the warming of the earth, acid precipitation, destruction of the ozone layer, sea pollution and other earth environment problems. It has been realized that waste disposal holds the key to "sustainable society".

**Title: WASTE MANAGEMENT IN THE MEGACITY OF SÃO PAULO, BRAZIL:
LOOKING FOR A SUSTAINABLE FUTURE****Author / presenter: Claudia Ruberg, Lara G. Martins, Geraldo G. Serra**
gegserra@usp.br**ABSTRACT**

This paper presents a general overview of the current waste system of the megacity of São Paulo. The city is experiencing a period of transition in its legal and operational framework with regard to SWM. São Paulo has followed the same waste management concept implemented in other cities of developing countries. It is mostly comprised of waste transfer and disposal. The current municipal government is formed by the Labour Party – which in early 90's set the first strategies to implement a new waste management system. However, the subsequent governments rapidly changed the system's philosophy. This period could be characterized by the monopoly of the waste system and political corruption scandals. Back to the head of the local government, the Labour Party has set a number of social and technical initiatives to get the grips to the waste problem. At present, solid waste issue plays an important role in the political agenda of the city. However, the monopoly of the operational system as well as the lack of transparency of some actors involved is still common features to the current SWM. São Paulo has all means to create a sustainable waste system whether political matters do not rule all other important issues.

Title: MOVING THE RCRA VISION FORWARD: THE NEXT GENERATION OF WASTE MANAGEMENT IN THE UNITED STATES

Author / presenter: David A. Cozzie, Robert Springer, Gary Ballard, Scott Palmer, David Hockey, and Angie Leith
cozzie.david@epa.gov

ABSTRACT

In its April 2003 vision paper, *Beyond RCRA: Waste and Materials Management in the Year 2020*, the United States Environmental Protection Agency (USEPA) explored possible changes in the management of waste materials and identified three goals for future waste management programs: (1) reduce waste and increase the efficient and sustainable use of resources; (2) prevent exposures to humans and ecosystems; and (3) manage wastes and clean-up chemical releases in a safe, environmentally sound manner. To achieve the first two goals requires the USEPA and others to evaluate environmental impacts from a product's initial design (e.g., use of recycled materials) to the end of its useful life (e.g., recycling vs. disposal). In this paper, we present an approach for moving towards a "cradle-to-cradle" paradigm for waste and materials management. In particular, we present estimates of the current volume of waste within the US waste program. This data effort, or "Waste Wheel," provides USEPA a starting point to evaluate wastes and determine appropriate management approaches such as guidance or voluntary programs. We also present a framework developed by USEPA to evaluate the goals of the program in terms of risk to human health and the environment, economic impact, and general societal benefit.

Session: Developing Countries Issues and Experiences**Title: ISWM – REGIONAL GUIDELINES IN DEVELOPING COUNTRIES OF THE MASHREQ AND MAGHREB REGION (METAP – RSWMP)*****Author / presenter:** Dr. Belherazem Aziz, DBh@gkw.com**ABSTRACT**

Solid waste management in the beneficiary countries¹ of the Regional Solid Waste Management Project (RSWMP) is an immediate priority.

Over 80 million of 160 inhabitants live in urban areas that already have difficulty meeting the basic service needs.

Across the region, countries spent approx. \$US 325 - 400 million in 2000 on SWM. Increasing waste generation will increase this amount in future.

1998 - 2010 could see an increase of 44 percent in the amount of waste generated in the region.

Solid waste management sector is generally inadequately structured and regulated across the region, resulting in service inequalities, risks to public health and threats to environmental resources.

The project has been developed with the national governments of the region, to assist in catalysing appropriate responses to the challenge of effectively managing solid wastes. The project is funded by the EU and managed by the WB, that engaged the International Consortium GTZ-ERM-GKW for carrying out the consultancy services. One of the major activity/output of the project among others carried out by the IC is the ISWM-Regional Guidelines, which will target responsible for making decisions affecting solid waste management and the professionals who will implement those decisions.

Title: SUSTAINABLE DEVELOPMENT, FROM LOCAL TO GLOBAL, THROUGH INTERNATIONAL COOPERATION**Author / presenter:** Isarema M. Cioni, isarema.cioni@regione.marche.it**ABSTRACT**

Endeavouring to attain sustainable development means confronting and balancing human activities and the preservation of the environmental functions of our ecosystem. At the same time, the problems at stake make it necessary to define global positions and strategies to satisfy the planetary dimension of these problems. In view of the current insecurity and lack of cohesion all over the world, it is difficult to work in a uniform manner in all countries, but it is however possible to develop initiatives, in the different local realities whose impact increases the more the experience is widespread and transferable to other territories.

The process based on bottom-to-top experimentation and on the distribution and exchange of methods and results with other territories is implemented in the European Community as one of the models that can face and in part resolve similar problems, above all when specific policies or national and supranational trends do not exist.

For all these reasons, Marche Region has developed transnational waste management projects, which in some cases, have been approved and co-financed by the European Community. This is a regional policy engineered to face the problem of “waste”, even beyond its borders, comparing experiences with different countries since all the efforts made in our territory would otherwise risk being inadequate, and the prospect would be that so effectively envisaged by Calvino of Leonia of “*invisible cities*” cancelled and razed to the ground by the rubbish dumps of the neighbouring metropolis.

Title: INTEGRATED APPROACH FOR SUSTAINABLE SOLID WASTE MANAGEMENT IN SOME ASIAN COUNTRIES

Author / presenter: Ashok V. Shekdar and Masaru Tanaka
ashok@cc.okayama-u.ac.jp

ABSTRACT

Globally, Solid waste management (SWM) systems are being oriented to concentrate on sustainability issues; mainly through incorporation of 3R (Reduce, Reuse and Recycle) technologies. Asian countries are no exception. However, the degree and nature of improvements towards sustainability varies and depends on the economic status of a country. The high income countries, like Japan, could afford to spend more to incorporate 3R technologies in the system. While the weaker economies like India or China; where there is adequate awareness for such broader scope of SWM; the impediments in improvement are mostly attributed to weak economy.

Hence in this paper, after discussing various aspects related to sustainability, and role and relation of SWM with sustainable society; a situation analysis is presented to tackle the complexity and resolve the situation on generic basis to highlight the salient features of SWM systems; and to identify the factors responsible for poor performance. The results of the analysis indicate that there is a need for adopting multi-pronged integrated approach to achieve sustainable SWM addressing the issues like national policy and legal frame work; the institutional arrangement; appropriate technologies; a self sustained financial resource; public awareness and participation.

Title: ENHANCING EFFICIENCY OF LOCAL GOVERNMENT AUTHORITIES FOR SOLID WASTE MANAGEMENT FACILITIES

Author / presenter: Vilas Nitivattananon, Ph.D., Robert Gauger, P.E.
vilasn@ait.ac.th

ABSTRACT

This paper presents part of the results from a project intended at enhancing environmental management efficiency of local government authorities (LGAs) in Thailand for implementation of a program of establishing solid waste (SW) facilities including landfills for 15 sites in the years 2000-2001. The project activities comprised both technical and evaluation aspects. Key issues were assessed according to implementation stages of planning, construction, and operation. The issues were document availability and quality, construction and operation and maintenance (O&M) plans, and quality control. Results of overall evaluation showed that most sites were not initially operating according to international sanitary landfill standards, and capacity and operating lifetime of constructed facilities were determined to be much lower than originally planned. The needs for improved O&M performance were also assessed with recommended actions to incorporate both environmental protection measures and monitoring programs. Recommendations were made to further enhance the SW management efficiency of LGAs with assistance of central and other concerned agencies.

Title: ASSESSMENT OF PRACTICAL SOLUTIONS PROPOSED FOR SOLID WASTE MANAGEMENT IN PUNJAB AND SOUTHEASTERN ANATOLIA

Author / presenter: Selmin Burak , Martin Steiner and Hannes Posch
sburak@istanbul.edu.tr

ABSTRACT

At the turn of 21st century solid waste constitutes one of the major environmental pollution component in many developing and/or lower-income countries, in particular. Pollution and health risks generated by solid and hazardous waste disposal are one of the most important issues concerning environmental management. Open dumps have been a common practice for the disposal of all kind of waste resulting in soil and water resource contamination by leachate, creating odours, fires and methane explosions. Litter and haphazard waste disposal cause significant environmental pollution, resulting in severe negative impact on natural resources and health. Collection of solid wastes from household and small trades, construction and operation of waste disposal infrastructure fall under the responsibility of local communities. In most middle-lower income countries, local authorities fail to fulfil their duty in many instances due to low level of investment capacity, legal and administrative constraints that undermine management flexibility and income generation. In this paper, rational waste management options aiming at practical solutions appropriate to the related area are discussed based on two separate case studies carried out in Punjab/Pakistan and South-eastern Anatolia Region/Turkey respectively.

Title: SOLID WASTE MANAGEMENT IN ERZURUM AND THE WASTE UNION OF ERZURUM**Author / presenter:** Tamer Atabarut, alcin Edgu, atabarut@boun.edu.tr**ABSTRACT**

Since solid waste management is a comprehensive concept, this paper mainly refers to the management of domestic solid wastes in the city of Erzurum. In parallel to the applications in many cities of Turkey, current technical and administrative applications for waste management in Erzurum threaten not only the environment but also the public health. Erzurum is a metropolitan municipality composed of four sub-municipalities. Waste collection and transport are among the responsibilities of the sub- municipalities, whereas the Metropolitan Municipality is responsible from waste disposal. The wastes collected via containers are disposed to a dump-site at Evren without any sanitary precaution. In order to proceed to the modern and sound solid waste management, and to decrease the investment and operational costs, some administrative measures should be taken in addition to the technical ones. An important tool to reach this goal is the establishment of a union of the municipalities for solid waste management. The proper functioning of the waste union mainly depends on the composition of the union assembly, financing model and organisational structure.

Title: EFFECTS OF PRETREATED HOSPITAL WASTE RESIDUES ON BIODEGRADATION OF MUNICIPAL SOLID WASTE**Author / presenter:** Qin Wang, Dahui Wang, Christoph Pasel, Martin Denecke, Jan-Dirk Herbell, wangqin7186@hotmail.com**ABSTRACT**

Three simulating landfill reactors were set up in order to investigate the effects of the hospital waste sterilization residue and of incineration residue on a household waste landfill site. Regular analyses on amount and composition of landfill gas as well as pH, COD, Ammonium-Nitrogen, conductivity, anion concentration and fatty acids of leachate were carried out. Methane reaches 50% within 43 days in the reactor of mixture of incineration residue and household waste, while it needs 95 days to reach 50% in the household waste reactor. The accumulative gas amount in the reactor of mixture of incineration residue and household waste in the same period is 4 times of the pure household waste reactor. The salt content of the leachate is much higher while the COD and fatty acids concentration is lower in the mixture of incineration hospital waste residue and household waste reactor than in the other two reactors. The results indicate that the incineration residue can not only accelerate the biodegradation process, but also enhance the stabilization of landfill site due to its sufficient alkalinity, wide specific area, sufficient cation and higher water-hold ability. The incineration ash seems to be advantageous for landfill gas utilization.

It needs less energy on the leachate treatment for the organics, but the high salt content of the leachate may add big load to the leachate treatment. Sterilized hospital waste has less effect on the municipal solid waste landfill site. The mixture of sterilized hospital waste and municipal solid waste has a similar biodegradation process as pure municipal solid waste.

Title: SOLID WASTES MANAGEMENT IN DEVELOPING COUNTRIES

Author / presenter: Carlo Collivignarelli, Sabrina Sorlini, Mentore Vaccari
cetamb@ing.unibs.it

ABSTRACT

The environmental pollution caused by improper wastes management is a problem concerning all the poor Nations. Also in a redeveloping Country such as Bosnia Herzegovina, pressing actions have to be performed in order to improve MSW management. The first part of this paper presents a study carried out by CeTAmb in order to define and design actions for waste collection and recycling in Zavidovici (Bosnia Herzegovina). In fact, only the centre of the town (about 16,000 inhabitants) is interested by the wastes collection service, while in the surrounding villages (about 30,000 inhabitants) wastes are abandoned anywhere. The second experience concerns plastic wastes, that are an important environmental problem for many African countries, like Senegal where, near Thiés, a Center for plastic collection and reprocessing for local manufacturing industries is operating since 1999. Today, plastic wastes are collected by hand and in Silmang center they are selected, cut in smaller pieces, manually washed and finally put into a rotating blades shredder. Plastic recycling now is very difficult for its low quality and CeTAmb's technical collaboration in this project was to study the physical and technical characteristics of recycled plastic in order to improve the recycling process.

Title: OPTIMIZATION OF THE MUNICIPAL SOLID WASTES SORTING AND COMPOSTING SYSTEM IN THE CITY OF ESTRELA, BRAZIL

Author / presenter: Odorico Konrad, Alberto Bezama, Rodrigo Navia,
Karl E. Lorber, odorico.konrad@telia.com

ABSTRACT

In this experience the separation system of a municipal solid waste treatment plant was modified in order to improve the working conditions for its operators, as well as to optimize the amount and quality of the recovered and processed waste streams. The biodegradation process of the separated organic fraction was also modified, in order to enhance the quality and the necessary degradation time of the organic matter present in the solid wastes. For that reason, a full-scale windrow composting system was constructed and operated for 50 to 80 days. With the implemented modifications, the weight loss in the biodegradation process because of organic matter degradation increased from 35.2% to 50.0%, and a biologically stabilized product was obtained.

Concerning the material streams a significant reduction of the solid wastes destined to landfilling was reached, as the original 38.3% were reduced to 24.7%. Finally, in terms of working conditions there were clear enhancements as well, as the applied modifications were highly appreciated by the plant operators.

Title: SUSTAINABLE TREATMENT OF SEWAGE SLUDGE PRODUCED BY HOTELS IN MAURITIUS USING TWO BULKING AGENTS.**Author / presenter: Romeela Mohee****ABSTRACT**

Tourism is the third pillar of the economy of Mauritius, which is a small island developing state of 1865 km² in the Indian Ocean. There are around 87 hotels in Mauritius, out of which 46 have more than 75 rooms and are required as per EPA 2002, to treat wastewater before discharge to the sea. Around 44 wastewater treatment plants in hotels on the island produce 7000 m³ of sludge on a daily basis. Currently, the sewage sludge is dried on site and sent to the sole sanitary landfill. Mauritius being a small island, there is huge competition for land between residential, industrial, commercial and agricultural sectors and other methods have to be investigated to safely treat the sludge produced. The main objectives of this study were to assess the potential of sewage sludge composting under tropical conditions, using two types of bulking agents (bagasse and woodchips) and to assess the feasibility of bioremediating oil contaminated soils. Composting of sewage sludge and wood chips and sewage sludge and bagasse in the ratio of 2: 1 (on a dry mass basis) were carried out in composters.

The composting process was monitored for a period of 45 days. Thermophilic temperatures were reached and maintained for more than ten days for the bagasse-sludge mix while the temperatures for the woodchip mix stayed 5°C to 10°C lower during the whole composting period. A decrease of 60% in volatile solids and a volume reduction of 50% were observed for the bagasse mix while the woodchips had a lower degradation rate of 49% of initial VS. Both composts had achieved a good degree of stability with a final respiration rate of 10 mgO₂/gVS.day for bagasse mix and 6 mgO₂/gVS.day for woodchip mix and a germination index of 86.7%.

The NPK levels were satisfactory and heavy metals content less than USEPA standards. Bioremediation involved composting the oil-contaminated soil with the sludge bagasse mix. Thermophilic temperatures were obtained for around 8 days and 50.8% of oil was degraded during the composting process. Sugarcane bagasse being an abundant material in the local context could be used as a bulking agent in the conversion of sludge generated from hotels into a safe product through aerobic composting.

Session: Environment Assessment , LCA & Quality**Title: VALUATION OF WASTE MANAGEMENT EXTERNALITIES: A COMPARISON REVIEW AND ANALYSIS**

Author / presenter: Tzipi Eshet, Ofira Ayalon, Mordechai, Shechter
eshet@techunix.technion.ac.il

ABSTRACT

Accessible and transparent data on externalities is crucial to waste management researchers, decision-makers and managers, when management strategies are successfully analyzed and implemented. This study is based on a thorough review of existing literature and research. Its primary objective is to assist the abovementioned in their decision-making by mapping, analyzing, comparing and synthesizing different valuation results for externalities associated with various types of pollution and disamenities related to landfilling and incineration of solid waste. The paper focuses on studies conducted since 1990, because the waste sector and valuation techniques are dynamic fields and have to be updated continuously. We discuss the issues and the limits of the valuation methods and analyze the estimates of all the studies.

Recommending “best values” for the externalities is an intricate task because of the high variability of the results, different assumptions and constraints and different scenarios analyzed, as well as the measurement units (eg: kg of emission, ton of disposal-waste). The valuations obtained in this study provide estimates of orders of magnitude that can be used by practitioners in the waste sector to address important policy questions.

Title: AUTOMATIC ENVIRONMENTAL MONITORING OF AERIFORM ISSUES

Author / presenter: Claudio Mazzari .Marina Modenesi
c.mazzari@tecnoborgo.com
depurazione@tesa.piacenza.it

ABSTRACT

TESA Piacenza S.p.A., the company that stores, sorts, processes and disposes of town and industrial waste in the Borgoforte area, in the commune of Piacenza, has set up a program to determine and improve the environmental position of the company in the area as regards its aeriform issues. A software program has been devised to ensure the utmost transparency in relations with the controlling body and users. It is based on mathematical models of the conveyance of pollutants and will allow:

- At the planning stage a preventive methodological approach to evaluate the effects on the environment of each measure to be taken.
- At the project stage use of the best available technology to improve the production – environment relationship.
- At the management stage: the assessment of the situations relating to production, emissions, discharges and trends in order to constantly minimize the effects on the environment.

Title: URBAN WASTE MANAGEMENT IN ITALY: THE RULES GOVERNING LOCAL AND MUNICIPAL AUTHORITIES – BALANCES – COMPARISONS**Author / presenter:** Aulo Magagni, Adelio Peroni, Gian Franco Saetti
saetti@csambiente.it**ABSTRACT**

The paper deals with the provisions on the main jurisdictions and duties of the different Authorities and stakeholders, both as to the niche of plants and, upstream, that of services. Compensations between the “loss” of specific prerequisites and the acquisition of others are pointed out with the purpose, pursued by the rules, of optimizing the system economic advantage for vast areas in the territory, grouping together different Local and Municipal Authorities (ELT) to form Optimal Territorial Administrations (ATO). The paper analyzes local and municipal applications of national regulations together with the different solutions adopted at regional and sub-regional level. The procedures mostly adopted for the legal application of rules concerning institutional relations in the first place and then operational relations for vast areas are pointed out. The paper takes also into account forecast specific and typical problems from local and municipal samples previously identified. The elements to be considered for an accurate comparison between the situation quo ante in relation with the new local and municipal bodies are analyzed.

Title: MUNICIPAL WASTE COLLECTION QUALITY SYSTEM**Author / presenter:** Salvador Gianluigi, gianlu.cali@libero.it**ABSTRACT**

We need to shift our attention from “waste” to the “product in need of improvement”, with the aim not only of placing the waste product on the market, but also of involving all the stakeholders through a policy of transparency and mutual involvement. The use of a top-down scalable management system eliminates barriers and uncertainties existing on interfaces between businesses and municipalities or between regions, provinces, consortia and municipalities. This will foster the creation of a flexible system capable of producing a complete and detailed set of objective-based service contracts, for both certified and non-certified businesses which find themselves either in the project-development phase or in the control of contract realization phase (the forms having to do with waste collection processes are for example a part of the contract). This system therefore enables the documentation and management of any waste collection/disposal system, from the traditional methods to door-to-door services.

The system is independent from the techniques and means of waste collecting/disposal and it furthermore offers an educational package aimed at the training of personnel and the creation of continuity regardless of changes in the work force. The system also facilitates the passage from waste-based taxes to waste-based tariffs, as well as the control (because waste collecting processes data are recorded in detail and stored as distinct separated waste). Finally, the system simplifies the job of private and public organizations interested in renewing their waste management systems so as to adhere to the rules outlined in the ISO9000, ISO 14000 and EMAS.

Title: OPTIMIZATION OF THE INTEGRATED SYSTEM FOR THE DIFFERENTIATED COLLECTION OF PLASTICS, EVALUATED THROUGH A LCA ANALYSIS

Author / presenter: Quintavalla Alberto, Melloni Riccardo, Neri Paolo, Bergonzoni Marco, albertoquintavalla@tin.it

ABSTRACT

The target of this work has been to evaluate the economic convenience and the environmental impact of the differentiated collection of plastics through a LCA analysis. The first part of the study examines the Italian scenario. An analysis has been carried out referring to the Italian panorama of rules, besides a valuation of the present state of the art as regards the recovery and recycle (mechanic, chemical) techniques, the thermo valorisation and the dump disposal. The second part of the study examines the collection system, transport, recovery and disposal of plastics by LCA methods, using real data of the Reggio Emilia Province. In this range considerations and comparisons have been carried out among possible alternative scenarios leading to the identification, by the Eco-Indicator 99 method, of the environmental advantages of the recycle faced with a greater economic impact as regards other solutions considered. Of the processes considered the PET recycle with -0.00172 Pt, the PE recycle with -0.00259 Pt and the PVC VINYLOOP recycle with -0.000639 Pt show the greatest prevented damages. As regards the incineration, the total prevented damage is given by $-8.12E-5$ Pt. The dump shows on the contrary a damage of $7.78E-5$ Pt.

Title: ANALYSIS OF THE MAIN INDICATORS ON MUNICIPAL SOLID WASTE GENERATION AND MANAGEMENT IN ITALY

Author / presenter: G. Ferrari , N. Ferrari , R. Sammito , R. Caggiano ferrari@gfambiente.it

ABSTRACT

Law 507/93 introduced important changes with regard to the municipal solid waste tax. These changes were the precondition for Article 49 of Law 22/97, in which the tax was replaced by a tariff.

It is necessary to gain knowledge of a number of parameters in order to determine the amount of money that users must pay under Law 507/93, Article 49 of Law 22/93 and Presidential Decree 158/99. Calculation methods should include experimental tests in order to quantify the amount of municipal solid waste produced by the different types of users. At the same time, it is necessary to know a number of indicators obtained by using parameters and simple mathematical formulas. The activity we have developed in this field allowed us to collect and/or determine important technical, economic and social indicators about municipal solid waste production in Italy in several municipalities, from 1993 until today.

This work enabled us to develop the most important Italian database on municipal solid waste production and management, then used to create the current body of legislation.

Title: THE APPLICATION OF THE ENVIRONMENTAL PRODUCT DECLARATION TO WASTE MANAGEMENT SERVICES

Author / presenter: **Maurizio Fieschi, Raffaella Bersani**
maurizio.fieschi@macroscopio.it

ABSTRACT

The paper describes one of the most important Integrated Product Policy (IPP) tools which is the Environmental Product Declaration (EPD). Through a description of main EPD features it indicates its suitability of contribution to a more sustainable production and consumption pattern. Some EPD system experiences are already on going both in Europe and abroad, and an important project is on going in order to define the requirements for an EPD system that can be applied at international level. The EPD can both apply to goods and services and an interesting application is on the product categories connected with the waste management services. In particular, three experiences have been conducted in the specific sector, in particular on the product category “collecting and disposal service of Municipal Solid Waste (MSW) in a sanitary landfill”, whose results are publicly available. The analysis of results showed that they are comparable and gives the possibility to compare the specific and the overall performances of the service supply.

At the moment, activities are on going to extend the application of the EPD to other waste treatments such as composting and incineration.

Title: BIOAVAILABILITY EVALUATION ON HEAVY METALS IN ASHES FOR WASTE DISPOSAL SITE

Author / presenter: **Aya Yamada and Yoshiro Ono,**
dns14607@cc.okayama-u.ac.jp

ABSTRACT

In Japan many of waste disposal sites are full to capacity of waste, and before long they must be utilized for other purposes such as parks, golf links and so on.

In consideration of this reality, it is axiomatic that we should conduct the risk assessments estimate the exposure to humans of hazardous contents. In this study, we applied bioavailability to assess the risks of waste. Firstly, bioavailability-predictive tests utilizing artificial stomach and small intestine solutions were carried out. We have found that some heavy metals dissolved more fully in the model small intestine solution under a neutral pH. Secondly, human intestinal cell culture model Caco-2 cells were cultivated on the apical side of monolayer and exposed to the extractions in the model small intestine solutions. Some metals dissolved from simulated small intestine solutions of some samples, however, their concentrations in the basal side were not detected. It is suggested that those metals could not pass through the intestinal wall. On the contrary, others, however, arrived at the basal side by passing through the Caco-2 cells, which shows that those metals can be absorbed into the small intestine.

Title: POLICY EVALUATION FOR SOLID WASTE MANAGEMENT BY WLCA IN JAPAN**Author / presenter:** Masaru Tanaka, Ayaka Nishimura
maxta@cc.okayama-u.ac.jp**ABSTRACT**

Solid waste management (SWM) system is oriented towards its contribution to sustainable society. At this juncture, it has been felt necessary to evaluate the environmental consequences of various SWM options so as to adopt environmental friendly technologies for waste management. In order to perform quantitative analysis, recourse has been taken to LCA techniques. A PC based software, developed for this purpose, has been modified to facilitate its use by professionals working in waste management. Basically, in keeping with the local constraints, alternative scenarios would be formulated. The software would be used to quantify the environmental impacts, resource recovery and expenditure for each scenario. This quantification would help in decision making while selecting a particular scenario. The proposed methodology is validated for the real life situation of Okayama city. In this paper, various details of the analysis including WLCA software, its modification and its validation through case study would be discussed.

Title: COMPARATIVE ANALYSIS OF THE KRAKOW AND STOCKHOLM MUNICIPAL SOLID WASTE MANAGEMENT SYSTEMS**Author / presenter:** Tomasz Stypka, stypka@s5.pk.edu.pl**ABSTRACT**

The author applied the first version of the Integrated Municipal Waste (IMW) model developed by White P.R., Franke M., and Hindle P., to analyse the present and the planned waste management systems in the two cities; Krakow, Poland and Stockholm, Sweden. The two cities share several similarities, but also represent two different municipal waste management systems. Size, climate and population is very much the same in the these cities, but the Swedish Municipal Solid Waste (MSW) system is based on the technology of incineration with the extensive “kerbside” and “bring” recycling system while the Polish system is far more traditional: relying on landfilling with the small “bring” recycling program. Since the Swedish model is also a goal model in the Krakow municipality the comparison was of additional interest.

The result of the model analysis is a set of total emissions of different components to air and water as well as statistics about the energy consumption and volume of disposed solid waste. The economic information about the system is also presented.

To help in the decision process the integration of the model results is proposed. The author proposes the integration of the emissions based on the Polish emission fees and calculated toxicity ratio.

As a result of this integration the environmental impacts on water and on air are presented in monetary units and easily can be compared and combined with the economic figures. Such integration allows the comparison of the Krakow and Stockholm systems.

Title: EMAS ENVIRONMENTAL REVIEW OF A WASTE TO ENERGY PLANT

Author / presenter: Massimo GUIDO, Lorenzo LIBERTI, Michele NOTARNICOLA, Roberto PISCONTI
massimoguido@tin.it

ABSTRACT

This work is aimed at analyzing the methodology of application of the EMAS Regulation 761/2001 [1] investigating in particular the Environmental Review and addressing the impacts of waste-to-energy (WTE) plants.

The methodology proposed examines the different operative steps of Environmental Review; carrying out it more accurately through two new tools in order to get the decisional process as objective as possible:

- A new proposal of assessing the significance of plant environmental aspects.
- Modelling environmental performances of WTE plants.

The results of this study are:

- Modelling environmental performances of WTE plants by means of a prevision model suitable for analysing mass and energy flows.
- An innovative methodology for assessing critical environmental aspects of the plant to be properly accounted for in the related environmental management system.

The new methodology has been positively tested at the WTE plant that treats the municipal solid waste (MSW) of the city of Taranto (S.Italy).

Title: ENERGY AND MATERIALS FLOW MODELLING OF MSW: OPTIONS FOR MANAGEMENT OF THE PLASTICS FRACTION IN HOUSEHOLD WASTE

Author / presenter: Paul J Dacombe, Charles J Banks, Sonia Heaven, Vladimir Krivtsov, P.Dacombe@soton.ac.uk

ABSTRACT

This paper describes a model developed to analyse the energy footprint associated with the collection, separation, processing and disposal of Municipal Solid Waste, allowing evaluation of the different options for its management. The model starts from the point where material becomes 'waste' and follows it through until disposal and/or processing, determining the energy consumption for each stage.

The analysis is illustrated using a case study of the plastics fraction within household waste, and the results show that the major source of energy savings from recycling is through increased use of recycled plastics in the manufacture of new plastic goods. There is a maximum reduction of between 45.5 – 54.9 %, depending on collection method, when compared to the base-case scenario. The waste management option that gives the lowest energy footprint is dependent on the collection method, what plastics are being recycled, and the level of incineration of the residual waste stream. Generally, at low-medium levels of incineration the best option would be a combination of recycling plus incineration. Conversely, at high incineration levels, the best option would be incineration without recycling of the plastics.

Title: EMS AND WASTE MANAGEMENT: THE CASE STUDIES OF TWO ITALIAN LOCAL AUTHORITIES**Author / presenter:** Alberto Quaglino, Claudio Comoglio, Serena Botta
claudio.comoglio@polito.it**ABSTRACT**

The waste management is a relevant environmental aspect to be considered and assessed while implementing an Environmental Management System (EMS) in accordance with ISO 14001 or EMAS (Reg. CE 761/01) requirements. In Local Authorities waste management is one of the institutional tasks having a significant influence on quality of life and environment safeguard, and therefore the implementation of an EMS, through the Initial Environmental Review and the consequent definition of environmental programmes and operational procedures, constitutes a useful tool for the continuous improvement of the Municipality's environmental performances. In this paper the experience of the only two Local Authorities in Piedmont Region (Italy) that have implemented an Environmental Management System (Cesana Torinese, a small touristic mountain town that will be one of the sites of the XX Olympic Winter Games Torino 2006, and Poirino, a middle size rural city in the shelter of Turin) is presented, outlining the improvements in urban waste management obtained through this approach in both cases despite the different characteristics of the two Municipalities.

Title: THE PRODUCTION OF HIGH QUALITY RDF IN THE PLANT AT VESTA DI FUSINA VENEZIA**Author / presenter:** Ing. Paoli Simone, Ing Teardo Gianni, Ing. Marino Massimo,
Dott. Baldoni Francesco, Dott. De Rossi Leandro, paoli@ladurner.it**ABSTRACT**

Among the solid waste disposal systems the production of RDF represents an option which is still being debated, also owing to the very heterogeneous production of this product. The aim of this report is to present the material and energy balances of the RDF production plant of the integrated pole of Fusina, as an example of a system with high quality process and product; it is a study-case about a particular situation, which shows that the choice of RDF production cannot beforehand be considered as disadvantageous.

The method used is that of the LCA-studies, based on literature and experimental data derived from the plant of Fusina, according to ISO 14040.

About two years after the plant became operative, there are many data available which allow to workout a reliable analysis of material and energy balances of the plant. On the basis of these consolidated data, it will also be possible to obtain reliable results concerning the environmental impact of the plant itself and of his products. Furthermore, the analysis of the RDF co-combustion in the thermoelectrical coal power plant of ENEL permit a complete evaluation of the whole cycle of civil waste disposal.

The obtained balances allow demonstrating the suitability of the system from the energetical point of view, based on the co-combustion of the produced RDF in the thermoelectrical power plant of Fusina as first outlet. Also from the environmental point of view the obtained results are completely satisfactory as concerning the avoided impacts and the recycled products.

Title: LIFE CYCLE ASSESSMENT OF A 1ST CATEGORY LANDFILL WITH ENERGY RECOVERY FROM BIOGAS**Author / presenter:** Irene Taddei, Marco Bergonzoni, Paolo Neri, Gigliola Spadoni, irelaide@libero.it**ABSTRACT**

The study regards the landfill of 1st category located in Poiatica (Carpineti, RE) and managed by AGAC S.p.A.; it examined the case without and the case with energy recovery, that has been realized since June 2003, through an engine fed by the biogas and coupled with a 625 kW generator, and with the benefit of the Green Certificates. The aim is to compare the two cases, mainly from an environmental point of view, quantifying the advantage due to the energy recovery. In each case it was considered: fittings and fixtures, energies involved and emissions in the environment.

The study followed the LCA (Life Cycle Assessment) methodology and used the software SimaPro 5.0, referring to the Eco-Indicator 99 as method to evaluate the potential environmental impact. The energy recovery produces a 71,5% reduction of the potential environmental impact; moreover, since the suction efficiency is an uncertain value, it was calculated its lowest limit (about 71,6%) under which the avoided impact due to the production of energy from biogas is lower than the impact caused by the not sucked biogas.

Session: Hazrdous & Health Care Waste, Recovery

Title: EVALUATION OF ORGANIC CARBON LEACHING POTENTIAL FROM TREATED INCINERATOR BOTTOM ASH USING CONVENTIONAL AND GREEN PROCESS METHODOLOGIES

Author / presenter: Andre L. Guimaraes, Tetsuji Okuda,
Wataru Nishijima, Mitsumasa Okada
alguim@hiroshima-u.ac.jp

ABSTRACT

The objectives of this study are to evaluate the efficiency of washing solvents, i.e, water, sodium hydroxide, hydrochloric acid and acetic acid, for organic carbon leaching potential reduction (OC-LPR) and their effects on organic carbon leachability from Municipal Solid Waste (MSW) incinerator bottom ash samples from three distinct MSW Incineration facilities in Japan. The interactions of organic carbon with main elements in bottom ash, i.e, calcium, were also focused in this work. Furthermore, ultrasound assisted washing was applied aiming to enhance the efficiency of washing. Acid washing was more efficient than water and NaOH washing for OC-LPR. Organic carbon was leached with calcium by acid washing, whereas calcium was not leached by water and NaOH washing. Additional release of organic carbon, which would be blocked in the solid matrix by calcium species, can be expected in acid washing. Ultrasound could remarkably enhance the efficiency and shorten the washing time of incinerator bottom ash for OC-LPR.

Title: DETERMINATION OF THE BEST APPROPRIATE MANAGEMENT FOR THE HEALTH-CARE WASTES

Author / presenter: Günay Kocasoy, B. Aylin Zeren, Meltem Kılıç
kocasoy@boun.edu.tr

ABSTRACT

The management of health-care wastes is among the most significant problems in almost all of the developing countries as it is in Turkey. It needs special handling for the safety of public health and the environment.

In order to decide for the appropriate management of the health-care institution wastes, data about the sources, location and the amount of the infectious wastes generated should be known. Taking this fact into consideration, a research has been conducted to determine the best management and final disposal methods for the wastes of health-care institutions in the Istanbul city as a good representative of an economically developing country.

The research consisted of the following steps:

- Survey with the questionnaires for the collection of data about the sources, types and amount of the health-care wastes.
- Development of database.
- Classification of wastes and determination of the waste minimization methods.
- Determination of the optimum waste collection network.
- Determination of the most appropriate disposal method from the point of views of public health, environment and economy.
- Improvement of the existing regulation and organizational structure in the waste management.

The results obtained can be used in most of the developing countries which has similar environmental problems and strict budgets.

Title: IN-SITU ACCELERATED BIO-STABILIZATION OF MSWI BOTTOM ASH AND SHREDDED INCOMBUSTIBLE MIXES

Author / presenter: **B. Inanc, Y. Inoue, M. Yamada, Y. Ono M. Kawasaki**
binanc@nies.go.jp

ABSTRACT

In this study, efficiency of aerobic and anaerobic landfill bioreactor operations for accelerating the stabilization of co-disposed MSWI bottom ash and shredded incombustible wastes (mostly from recycling facilities) were investigated using three test cells. The test cells have been operated for 1 year, and excavated for sampling at the end of the operation period. Substantial reduction in TOC and in-situ oxygen utilization and insignificant residual BOD₅ values in the leachates of Aerobic cell indicated the faster progress of stabilization in this cell.

Furthermore, leaching characteristics of the excavated samples (Bio-probe Bags) from each cell were investigated for assessing the stabilization level of the solid wastes. ANC patterns, leaching behaviour of DOC and heavy metals and substantially higher IC content of the samples indicated accelerated waste stabilization under aerobic landfill bioreactor conditions. Progress of stabilization in Anaerobic bioreactor and control cells was much slower.

Title: DEVELOPMENT OF A NEUTRALIZATION PROCESS OF HAZARDOUS WASTES OF THE OIL-FIRED POWER GENERATION WITH RECOVERY OF THEIR VALUABLE ALLOYING METALS

Author / presenter: Spyridon N. Karamoutsos, Irene E. Alexopoulou, Victor E. Stivanakis, Georgios Valkanos, Demetrios C. Papamantellos, skar@chemeng.upatras.gr

ABSTRACT

The power generating potential of the Hellenic Public Power Corporation, S.A. (P.P.C.) includes 40 oil-fired power stations. More than 500t of solid wastes are annually produced during the washing processes of their air pre-heaters and crude oil tanks. These residues are characterized as hazardous by the European Union directives. In the frame of the current research complete characterization of the residues was conducted and they were found to contain 1.6-13.4%V and 0.8-5.5%Ni. Sintering is the first step of the developed recycling process and is aiming at their enrichment in Ni and V by simultaneous desulphurization and decarburization by exploitation of their chemical potential for sintering. The evaluation of the effects of the ground disposal of the residues was the second step of the current study. Therefore simulation of their rainfall leaching was conducted and a process model was developed. Reduction smelting trial heats were conducted in graphite crucibles with the sintered and hydro-chemically pretreated residues as raw materials. The reduction process of the metal oxides was investigated in the temperature range of 1375-1600oC. The almost 100% recovery of nickel and 95% of vanadium was achieved by applying high smelting temperatures in graphite crucibles and utilizing iron silicon as reduction agent.

Title: PROPOSAL FOR A SUSTAINABLE HEALTHCARE WASTE MANAGEMENT IN ANTALYA CITY

Author / presenter: Bülent Topkaya, Tu_ba ÖZDEN , Mustafa Yıldırım Hüseyin Karaca, btopkaya@akdeniz.edu.tr

ABSTRACT

Rapid developments in medical technology and increased packaging have contributed to huge expansions in the volume of medical waste produced in Turkey. Much of the problem, however, lies not in the increasing volume of infectious waste but in the large quantity of nonhazardous solid waste with which it becomes mixed. Despite training programs, much non hazardous waste ends up in the red bags designating medical waste; once it finds its way into a red bag, even a soda can or a paperclip must be treated as potentially infectious. In order to control the medical wastes, the Turkish Medical Waste Control Regulation (TMWCR) came into force in the year 1993, as a part of the Environmental Act.

According to the regulation, all healthcare institutions are obliged to collect, transport and store medical wastes as mentioned in the regulation whereas the Metropolitan Municipality is responsible for the final transportation and disposal of these wastes. Medical wastes generated in the hospitals in Antalya City, are transported in special transport vehicle and dumped in a hole in the unsanitary landfill of the city, covered with a layer of lime. The only medical incinerator in the campus of the university is out of operation due to high costs of incineration. As no proper segregation takes place in the hospitals, infectious wastes are collected and disposed together with household wastes generated in the healthcare institutions. In this study, the aim is to present a sustainable medical waste management system for Antalya hospitals, which also complies with the Turkish MWCR.

Title: RECYCLING OF MUNICIPAL INCINERATOR FLY ASH INTO CEMENTITIOUS MIXES THROUGH A PRELIMINARY SOLIDIFICATION/STABILISATION PROCESS

Author / presenter: Teresa Mangialardi, Liliana Panei, Antonio E. Paolini, Luigi Piga, lilianapanei@tiscali.it

ABSTRACT

A cement-based solidification/stabilisation (S/S) process of washed municipal incinerator fly ash followed by the reuse of the S/S product as an artificial aggregate in Portland cement mortars was investigated. The S/S product was obtained from a mixture of 30 wt.% Portland cement and 70 wt.% washed fly ash (water-to-solid weight ratio = 0.47) aged for 180 days at 20°C and 100% RH. This product showed good dimensional stability, relatively high compressive strength (27 N/mm²), and satisfactory environmental quality. The reuse of such a product in cement mortars yielded compressive strengths in excess of 27 N/mm² that were comparable to those of control mortars when the nominal water-to-cement weight ratio was 0.62 and the replacement level of natural sand by artificial aggregate was not greater than 50% by mass. Leaching tests showed that, with respect to control mortars, the artificial aggregate-bearing mortars were characterised by increased acid neutralisation capacity, similar physical retention factors, and greater chemical retention factors for selected heavy metals (Cr, Cu, Pb, and Zn).

Title: DEVELOPMENT OF RAPID SCREENING METHOD FOR BROMINATED FLAME RETARDANTS IN PLASTICS BY TIME OF FLIGHT SECONDARY ION MASS SPECTROMETRY

Author / presenter: Jiro Naka, Hiroshi Kurokawa, Junji Kobayashi, Satoru Toyama, Noriko Hirano, Eiji Hara
Naka.Jiro@wrc.melco.co.jp

ABSTRACT

By Directive on RoHS, the use of six hazardous substances is restricted to new electrical and electronic equipment put on the market in Europe from 1 July 2006.

The estimation of the type and the content of brominated flame retardants is necessary in plastics of the equipment and the parts. The new technique by using time-of-flight secondary ion mass spectrometry (TOF-SIMS) is proposed for rapid screening test of these substances. We named this technique one drop extraction method.

The sampling method of brominated flame-retardants in plastic materials with toluene on silver substrate was investigated for analysis of trace organic compounds by TOF-SIMS. High impact polystyrene (PS) and polypropylene (PP) plates were prepared as evaluation samples containing Decabromodiphenylether (DeBDE) of 0.01-10wt%. Evaluation time that includes sample pretreatment time and measurement time was about 1 hour. The positive quasi-molecular ion (DeBDE+Ag)⁺ (DeBDE cationized with Ag) was suitable for estimation of DeBDE. It was proved that content and spectral intensity had the clear magnitude correlation within 0.01-10wt% content of DeBDE. It was found that the quick decision of whether the brominated flame retardants in the plastics is the substance restricted or not by Directive on RoHS is possible by this method. We can screen the substances in wide range of content of 0.01-10wt%. As a result, it can be expected that hazardous substance management which concerns Directive on RoHS/WEEE becomes more reliable.

Title: DEVELOPMENT OF A REDUCTION SMELTING PROCESS FOR THE ENVIRONMENTAL MANAGEMENT OF METALLURGICAL DUSTS**Author / presenter:** Theofani V. Tzevelekou, Hans Günter Geck, Peter van Hüllen, Friedrich Höfer, Demetrios C. Papamantellos
fani@chemeng.upatras.gr**ABSTRACT**

The ferronickel production of LARCO at Larymna, Hellas is associated with the production of around 200000t/y of nickelferrous dust collected in the gas cleaning systems of the Rotary Kilns (R/Ks). This dust contains in average 1.2-1.5% nickel and 4-5% carbon. A new “one-stage” environmental friendly process has been developed for the recycling of this dust by its direct reduction smelting in a Direct Current – Hollow Electrode Powder (DC-HEP) furnace. The characterization of the raw materials was followed by industrial heat campaigns in the 125t DC-HEP furnace at Georgsmarienhütte steelwork in Germany, where around 70t of the Ni-bearing dust and 2.5t of untreated laterite ore fines were directly smelted.

Nickel recovery of 93-99.9% was achieved, with no dust losses in the environment of the furnace. Final heats products were low nickel alloyed steel grades and various slag types regarding their chemical and mineralogical analysis, in order to investigate their suitability for utilization in the production of special cement types. The thermochemical metallurgical evaluation of the trials was performed.

The investigations performed in cements showed that the produced slags can be utilized in special slag-cements production using up to 40% slag. In conclusion, a zero residues industrial production process was developed for the recycling of the nickel bearing dust.

Title: SUSTAINABLE HEALTH CARE WASTE MANAGEMENT IN JAPAN**Author / presenter:** Masaru Tanaka, Naoki Kaneko, Nariaki Takahara,
and Ashok V Shekdar, maxta@cc.okayama-u.ac.jp**ABSTRACT**

Globally health care waste management (HCWM) systems are developed to isolate the problem of mixing of infectious waste with municipal solid wastes and thereby reducing the risk of spreading the infection. However, at any point of time, the HCWM systems have been closely related to the status of municipal solid waste management. Japan is no exception. Recently, many of the health care units are outsourcing the waste processing due to stringent standards for dioxin emissions from the incinerators. This has resulted in excessive financial burden and danger of illegal dumping thereby destabilizing the HCWM. Vis-à-vis, in the national drive towards sustainable society, variety of measures is being applied at different levels of waste management. Thus, HCWM systems are trying to stabilize under these externalities. Hence, a study is being conducted at Okayama University to assess the prevailing situation and propose a plan for sustainable HCWM. As a part of these studies, a nationwide questionnaire survey was undertaken to ascertain the situation before and after the enactment of dioxin regulations on variety of issues from health care units and municipal agencies. In this paper, results of these studies are presented so as to help develop sustainable HCWM.

Title: ANALYTICAL STUDIES USED AS TOOL TO PROVIDE EFFECTIVE SOLUTIONS TO BIOMEDICAL WASTE MANAGEMENT IN CAPITAL OF INDIA

Author / presenter: Dr. Shyamala Mani, Mr. Anil K Bansal,

ABSTRACT

The Indian biomedical waste management scenario is grim not only because healthcare waste and other such hazardous waste is not stored or treated properly but also because even the domestic waste which forms 75% of the healthcare waste that emerges from healthcare establishments (HCEs) is not separated, collected, stored or handled properly. Consequently, all waste that is collected from HCEs is infectious and tons of this infectious domestic waste collected from numerous HCEs and mixed with rest of the municipal solid waste becomes infectious. Municipal workers who handle waste manually, are exposed to hazards from such mixed waste because of the fact that besides dermal exposures to these hazardous substances, needle stick injuries and cuts, inefficient handling and loading from municipal waste bins also leads to aerosolization of pathogenic bacteria and viruses which can then spread diseases among them. Although there have been commendable initiatives by individuals, scattered groups and NGOs towards improving the situation in different cities and municipalities, the outreach capabilities of these few NGOs and individuals who are working in this field are limited. Hence coordinated action is urgently needed.

APPENDIX 4**WMAA – 2004 EUROPEAN TOUR
SITES VISITED**

Day	Site	Contact	Address	Description
Mon Oct 4	Vesta Spa	Francesca Faraon Gianni Teardo	Via della Geologia 31 (Fusina Industrial Area) Fusina ITALY	<ul style="list-style-type: none"> • Waste to energy plant. • Composting in biocell plant. • Selection and transfer station.
Mon Oct 4	Ansaldo Energia Spa	Gernot Stangl	Verona ITALY	<ul style="list-style-type: none"> • Treatment of domestic & industrial wastes. • Mechanical pre-treatment. • Digestion. • Waste to energy, production of RDF. • Maximum capacity: 40 tons of mixed domestic/hour.
Tue Oct 5	EcoDeco Spa	Gabriella di Marzio Paolo Albergoni	ITS - Lodi EcoEnergia - Corteolona ITALY	<ul style="list-style-type: none"> • Waste selection plant (Intelligent Transfer Station). • Waste to energy plant. • Industrial waste incineration plant.
Wed Oct 6	AVAG KVA AG	Marc Stammbach	Allmendstrasse 166 Thun SWITZERLAND	<ul style="list-style-type: none"> • Incinerator for residual household and commercial & industrial waste with steam and electricity production. • Flue gas treatment with integrated heavy metal recovery bringing all pollutants in enriched form back to the industrial market. • Commissioning mid-2004. • Capacity: 100'000 tons/year. • Input: Calorific waste and sewage sludge. • Investment inclusive project finance: 200 Mio. Swiss Francs (CHF) - approximately A\$230 Mio. • Financing by own equity (ca. 35 Mio CHF.), contributions from federation and state (ca. 75 Mio. CHF) and bank consortium. • Environmental Impact Study fully evaluated and approved.

Thu Oct 7	AZALYS	Marie-Jo Laluque	RD 190 Lieu dit "Les Bouveries" 78955 Carrier Sous Poissy FRANCE	<p>Waste to Energy Facility Processes domestic and industrial wastes to generate electricity. The facility meets the most stringent standards on gas use emissions, especially those of the Netherlands. The Plant handles:</p> <ul style="list-style-type: none"> • 85,000 tonnes domestic waste • 15,000 tonnes of waste from sorting and composting • 15,000 tonnes of non classified industrial waste
Thu Oct 7	Gennevilliers	Veronique Volat	Port de Gennevilliers21 Rue du Bassin 99230 Gennevilliers FRANCE	<p>Very large facility located on Seine river bank for C&D and C&I:</p> <ul style="list-style-type: none"> • C&D transfer station and sorting facility. • Transfer is made by barge. • C & I MRF. • 60,000 tonnes C & D waste; 25,000 tonnes wood waste; 35,000 tonne transfer station.
Fri Oct 8	Limeil Brevannes	Veronique Volat	Rue Ses Long Rideaux 94450 Limeil- Brevannes FRANCE	<p>MRF for domestic recyclables (packaging, paper, magazines, cardboard):</p> <ul style="list-style-type: none"> • Capacity 35,000tpa. • State of the art facility. • Automated sorting of plastic bottles.
Fri Oct 8	REP		CV1 etnre RN16 et CD10 95720 Bouqueval FRANCE	<ul style="list-style-type: none"> • A 250 hectare model unit (with 50ha landscaped field), a treating capacity of 1.100.000 ton per year. Latest modern equipment and infrastructure waste origin, reduce all kinds of emissions, treatment and waste recovery, high level security. • Biogas recovery into energy collection and production of renewable energy from waste - production of 80 million of electric KWH per year, which is the yearly consumption in electricity of a 30,000 inhabitants city.

Fri Oct 8	CGECP Auror		Z1 des Bethunes Avenue du Feif 95310 Saint-ouen- L'Aumone FRANCE	<p>Integrated waste management system including:</p> <ul style="list-style-type: none"> • A municipal-clinical waste incinerator processing a total of 160,000tpa of municipal and clinical waste and provides hot water (150,000 MWh/year of thermal energy) to heat 30,000 homes in the area. 7 MWh of electricity is produced to service on site needs with the excess being provided to EdF. • A MRF with a capacity of 80,000tpa recovering glass, paper and plastics. • Undercover composting facility, which produces 13,000tpa of compost. Composting is carried out in windrows and 6 weeks is the normal production time. Its high quality allows agricultural use. • The integrated treatment centre serves a population of 200,000 people with selective collection currently from 25,000 residences.
Mon Oct 11	Hersin Landfill	Sylvain Daumy	SITA FD62 530 Hersin Coupigny FRANCE	<ul style="list-style-type: none"> • State of the art MSW landfill (60,000tpa). • Advanced leachate treatment (reverse osmosis and membrane bioreactor). • Electricity generation from biogas.
Mon Oct 11	Itradec	Alexandre Urbain	Rue Du Champ De Shislage 1B 7021 Havre (Mons) BELGIUM	<p>Council owned and operated facility. MBT with anaerobic digestion Front end sorting plant (100,000tpa) producing:</p> <ul style="list-style-type: none"> • 50,000tpa of RDF for cement kilns. • 3,000tpa ferrous. • 12,000tpa inerts. • 35,000tpa organic fraction for digestion. • Digestion producing compost and biogas generating electricity.
Tue Oct 12	Grammont	Wim de Croo	Schendeldbeke Industrial Area Dagmoedstraat 105 B 9500 Geeraardsbergen BELGIUM	<p>Biowaste composting facility:</p> <ul style="list-style-type: none"> • Food wastes from households and green waste (collection together in "grey" bin). • Composting in hall with automatic system (Buhler system). • Capacity 50,000tpa.
Wed Oct 13	MBA Muenster	Marc Stammbach	Zum Heidehof 52 Munster GERMANY	<ul style="list-style-type: none"> • Residual household and commercial & industrial waste is recovered as recyclables and fuel substitute. The remaining putrescible fraction is stabilised and goes to landfill.
Wed Oct 13	ReadyMix Cement Kiln	Marc Stammbach	Beckum GERMANY	<ul style="list-style-type: none"> • Cement production with up to 60% thermal input from fuel substitute.

Thu Oct 14	Lippewerke	Marc Stammbach	Brunnestr. 38Luenen GERMANY	<p>Diverse waste streams are recycled to clean products for use in industry. The site features:</p> <ul style="list-style-type: none"> • Company Head Office and Administration. • Laboratory Services • Fluid Bed Incinerator for Solid and Liquid waste 90,000T/y. • Processing Plant for High Risk Meat and Food residuals 85,000T/y. • Substitute Fuel Generation Plant 35,000T/y. • Timber Processing 60,000T/y. • Automated Composting Plant for source separated Organic Waste 70,000T/y. • Animal Rendering Plant. • Recycling of Flue Gas Cleaning Residues/Gypsum 250,000T/y. • Recycling of Metal slags 100,000T/y. • Reprocessing of Industrial Chemicals into Water Purifying Agents 30,000T/y. • Transfer Station. • Landfill.
Thu Oct 14	Power Station Mark Elverslingsen	Marc Stammbach	Elverslingsen GERMANY	<ul style="list-style-type: none"> • Electricity production with fuel substitute.
Fri Oct 15	RheinMain Biokompost	Marc Stammbach	Peter Behrens Str. 8 Frankfurt am Main GERMANY	<ul style="list-style-type: none"> • Anaerobic Digestion / Composting Plant (Kompogas-System) from source separated organic fractions producing renewable energy.
Fri Oct 15	FES Paper Sorting	Marc Stammbach	Schielestr 25 Frankfurt am Main GERMANY	<ul style="list-style-type: none"> • Latest Paper Sorting Technology in a State of the Art Paper-Material Recycling Facility.

Additional Site Visit

David Beard	Compact Power Bristol	Nic Cooper	Hydo House St Andrews Road Avonmouth Bristol UNITED KINGDOM	Pyrolysis and Gasification process to recover energy from municipal wastes and priority wastes.
----------------	-----------------------------	------------	--	---

APPENDIX 5

A dirty business **INCINERATION**

www.GREENPEACE.org.au



Photo: Waste ash from Danish incinerators. Incinerators produce piles of toxic ash

WHAT YOU CAN DO IS PHONE OR WRITE TO:
**The Minister for Primary Industries, Water
and Environment, Hon Bryan Green.**

Ask him to revoke TEST's incinerator
permit.

Email: bryan.green@parliament.tas.gov.au
Phone: 03 6434 6252
Post: GPO Box 44
Hobart
Tasmania 7001

For more information visit:

www.greenpeace.org.au/toxics

www.GREENPEACE.org.au

APPENDIX 5 (Cont)

A dirty business
INCINERATION
www.GREENPEACE.org.au

*"Incineration only makes sense if we had another planet to go to."
Dr Paul Connett, US waste management expert*



TEST Energy Pty Ltd plan to build Australia's first municipal waste incinerator in Brighton, Tasmania.

An incinerator in Tasmania raises serious public health and environmental pollution issues

Cleaner and more sustainable methods of waste treatment and resource recovery are being implemented in Australia and worldwide

www.GREENPEACE.org.au

APPENDIX 5 (Cont)**THE PROPOSAL****WASTE MANAGEMENT**

- TEST have been reported as saying that the incinerator will ‘reduce landfill in the southern region by 99% by 2002’.

TOXIC EMISSIONS

- TEST’s proposal says it will not exceed the dioxin pollution standard because they use ‘state of the art’ Seghers technology.

HEALTH

- TEST’s proposal says there will be ‘negligible’ predictable health impacts.

HEALTH RISK ASSESSMENT

- TEST’s proposal bases the ‘negligible health impacts’ on a health risk assessment developed for a proposed Global Olivine waste incinerator in Western Australia. The WA health risk assessment was based on Global Olivine incinerators in Canada and the US.

ENERGY

- TEST’s proposal says that the incinerator can generate clean green energy.

JOBS

- TEST’s proposal says the plant will employ 250 people during construction and 100 people when operational.

COST

- TEST’s proposal says there will be a cost saving to councils if they use their incinerator instead of sending municipal waste to landfill.

VIABILITY

- TEST’s originally said they need to process 120,000 tonnes of waste per year to be viable, but TEST has announced the possibility of downscaling the plant by half.

APPENDIX 5 (Cont)

THE CONCERNS

WASTE MANAGEMENT

- The TEST incinerator can produce 19,000 tonnes of toxic ash per year, at least 3,000 tonnes which is highly toxic will be landfilled.
- 60% of Southern Tasmania's municipal waste and 30% of Tasmania industrial waste will still need to be landfilled.
- Incineration locks us into waste production, not reduction.

TOXIC EMISSIONS

- A number of Seghers incinerators have been shut down for dioxin pollution reasons.
- A Belgian incinerator, which TEST refers to in its proposal, breached dioxin standards by 1,300 times and was closed down. There has been huge public protest against Belgian incinerators.

HEALTH

- Pollution including heavy metals and dioxins will create a long-term health risk.
- Dioxins can cause cancer as well as reproductive health problems, hormone disruption, immune disorders, diabetes and respiratory diseases. There is no safe level of dioxins.

HEALTH RISK ASSESSMENT

- The Canadian plant does not operate well and has attracted public concern.
- The USA plant is visibly falling to pieces, failed its pollution limits, illegally dumped its toxic ash and was shut down. This is not a sound basis to claim 'negligible health effects'.
- No independent health impact assessment was undertaken for the Tasmanian incinerator
- The WA Global Olivine incinerator's development permit has expired and it is reported that the local council is no longer in negotiations with Global Olivine.

APPENDIX 5 (Cont)

ENERGY

- Waste is a dirty and inefficient fuel.
- Burning waste is a waste of energy, as it cannot recover the energy involved in making products, recycling conserves this 'embedded energy'.
- TEST can burn plastics and other materials produced from non-renewable petrochemicals and is not renewable energy by law.

JOBS

- Many of these jobs will actually be with a recycling business, and may not be new jobs.
- Pro-active support for re-use and recycling leads to more effective job creation.
- For example, Canberra's world-leading implementation of a No Waste strategy without incineration has created 200 NEW jobs.

COST

- Australian reports show that incineration costs 2-3 times as much as current waste management arrangements, with up to 4 times the gate fee.
- Councils will not save any of the costs of maintaining current landfills as they will require ongoing management.

VIABILITY

- TEST announced that they may down-size the plant to process only 90,000 tonnes. This puts the viability of the plant into question.